Ballistic Weft Insertion

Prof. Dr. Emel ÖNDER

Ass.Prof.Dr.Ömer Berk Berkalp

Ballistic Weft Insertion

- The shuttle and gripper projectile are projected bodies.
- When imparted the initial speed, move across the shed due to inertia without any possibility of influencing the course of their flight.
- The gripper projectile is fully controlled in the shed whereas the shuttle control is partial.

Ballistic Weft Insertion

- Shuttle

- Projectile

- Three phases of weft carrier motion

- I. Acceleration

- II. Free flight

- III. Checking (retardation)

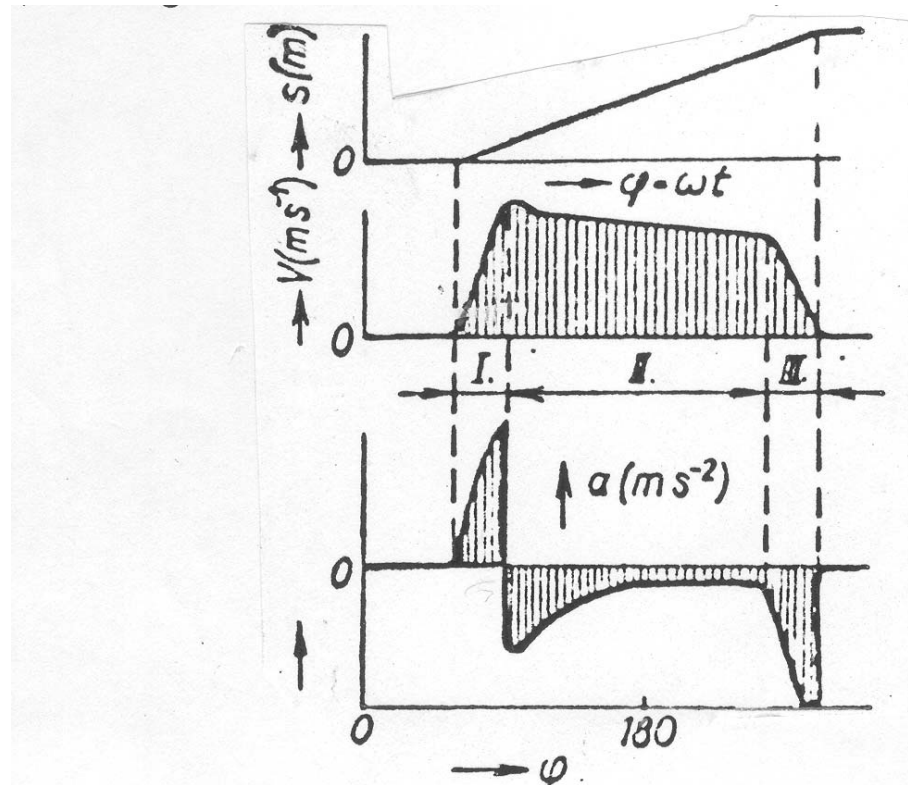

Fig. 6.1 The path, speed and acceleration of the weft carrier

$$\phi = \omega t = \text{constant} \times \text{time.}$$

ω : angular speed of the crank shaft

Ballistic Weft Insertion

- The values of **the carrier acceleration** at the start and its **retardation during braking** are **not constant** and are determined by the types of the mechanisms used.
 - The retardation during the free flight (phase II) is dependent on
 - the resistance of the weft to unwinding from a package or a weft accumulator
 - the quality, unevenness and oscillation of the projectile guiding segments,
 - wavy shuttle or gripper projectile motion,
 - frictional resistance of weft carrier to guide path, etc.
-

Two main types of mechanism for imparting motion to a weft carrier. These are:

Shuttle Picking

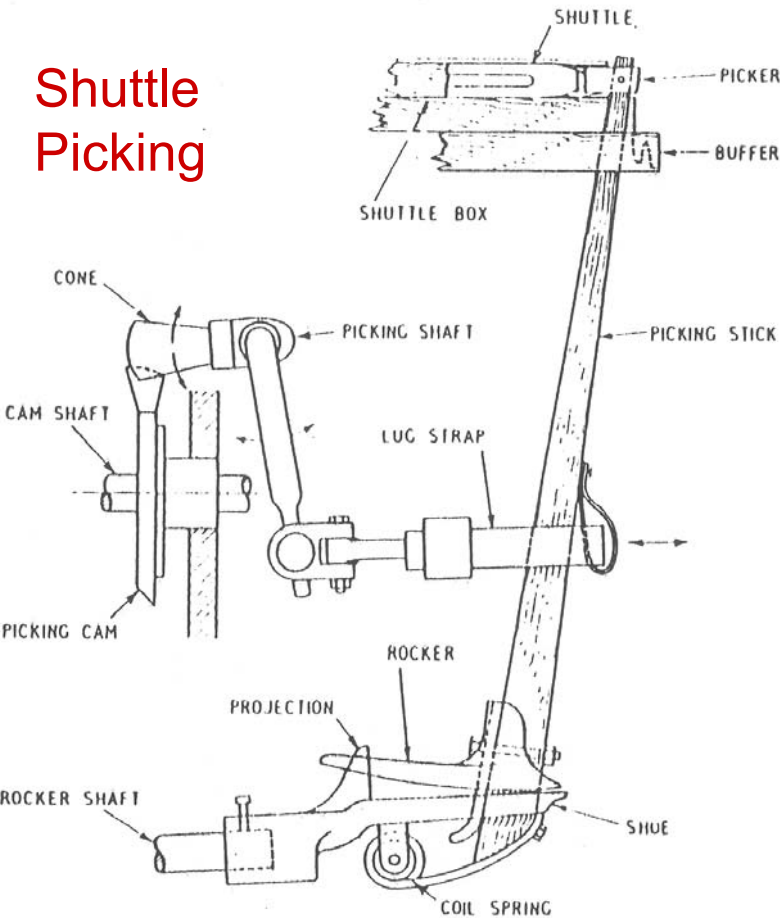

Fig. 1.10 Cone underpick mechanism.

a. Mechanisms that generate energy when it is required by using a cam to displace the picker against the inertial resistance offered by the shuttle.

- The shuttle speed varies with the loom speed
- The force acting on the shuttle tends to increase to a maximum about halfway through the period of acceleration and then to decrease to zero at the instant at which the shuttle loses contact with the picker.

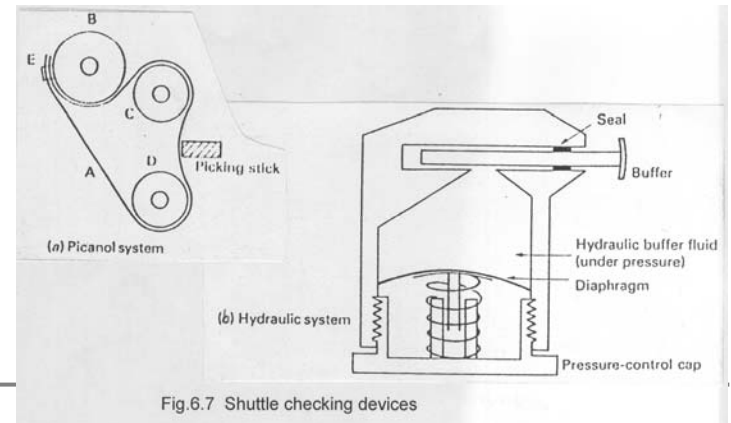
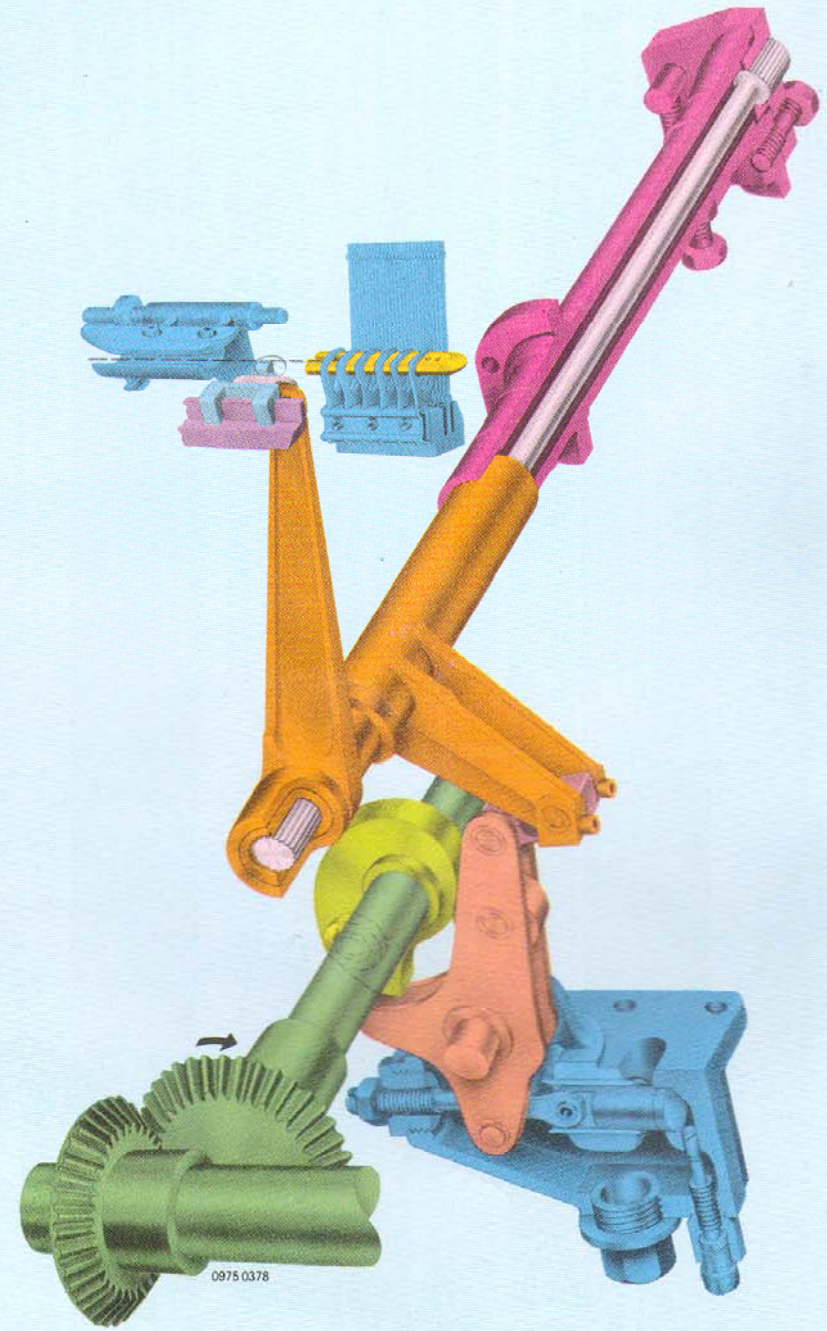
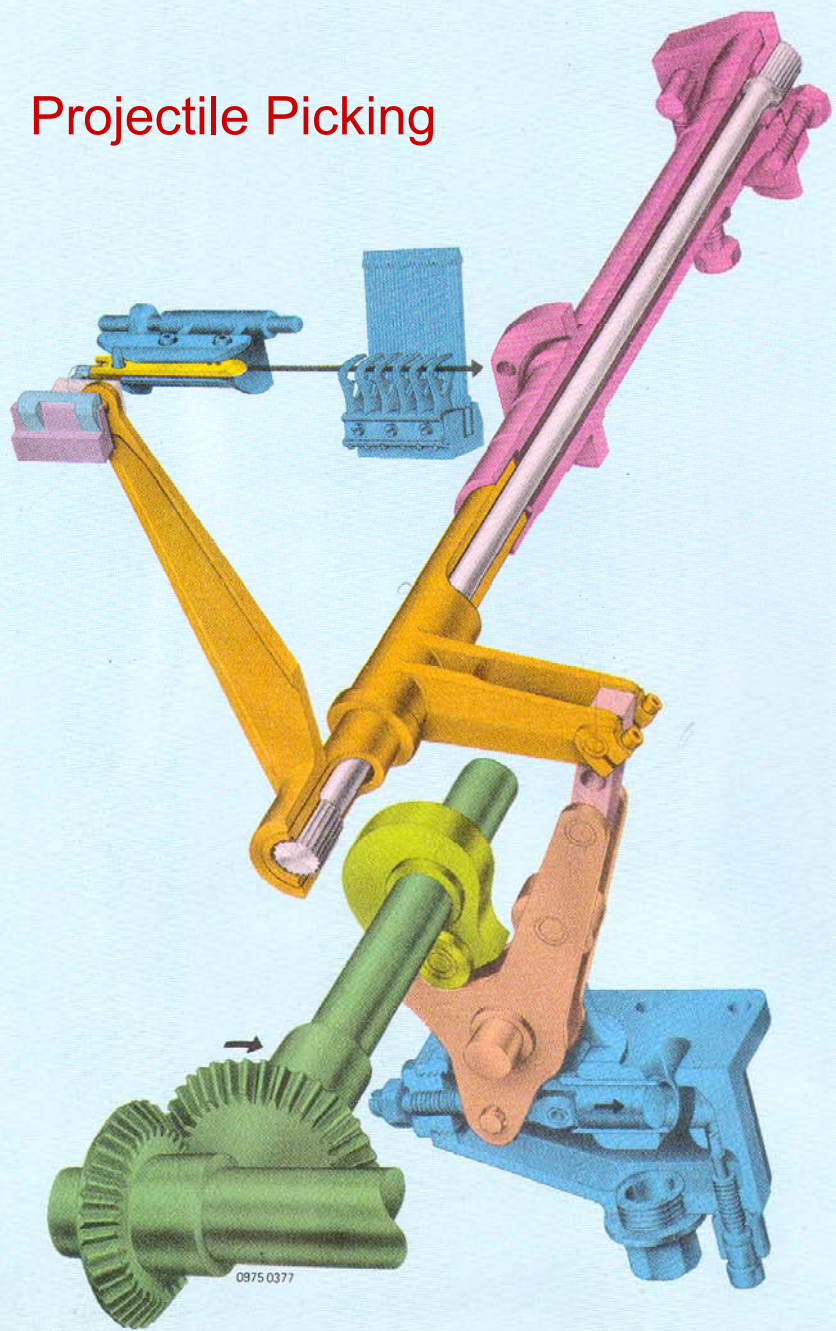

Fig.6.7 Shuttle checking devices

Two main types of mechanism for imparting motion to a weft carrier. These are:

- b.** Mechanisms that generate and store energy in a spring or torsion rod and release it suddenly when required.
 - Because the energy is released suddenly, the weft carrier speed is independent of the loom speed.
 - The force exerted by the spring or torsion rod is greatest at the instant of release and then decreases steadily to zero if the spring or torsion rod is allowed to return to its unstressed state at the end of the pick.
 - The uniform acceleration is unattainable with mechanisms of type (a) We can obtain more uniform acceleration with mechanisms of type (b).

Projectile Picking



Shuttle flight and its timing

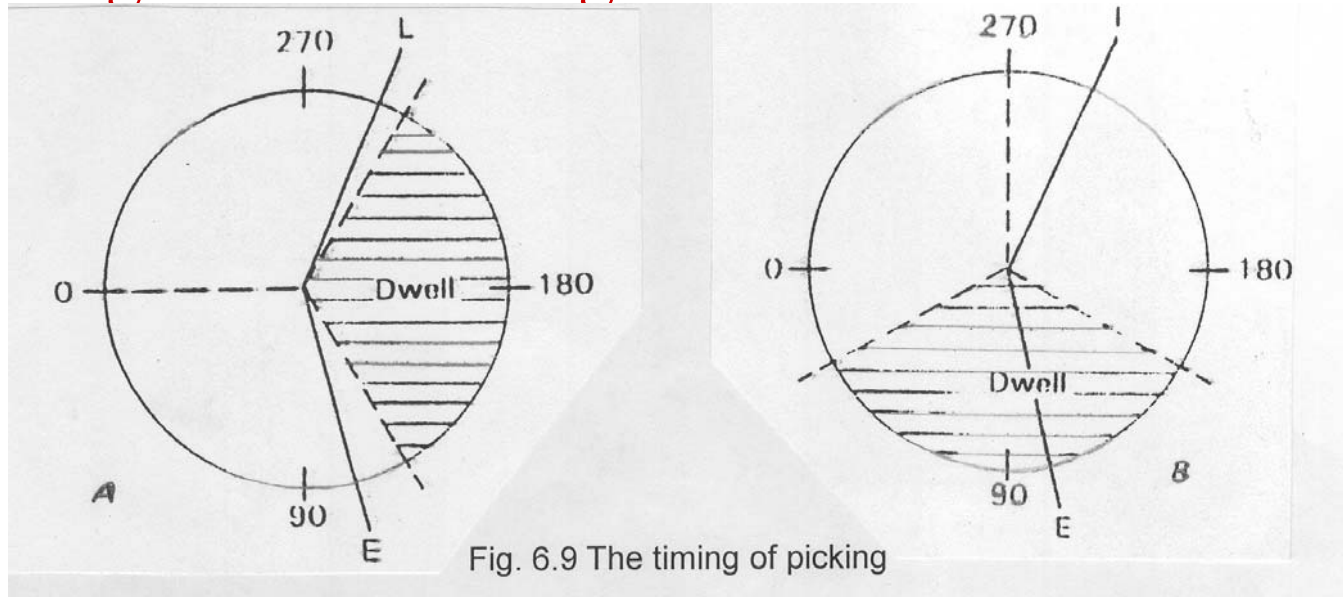

- The **earliest practicable time for the entry of the shuttle into the shed** is determined by **the position of the reed** and **the size of shed**.
- For a sley eccentricity ratio of 0.2, the reed has attained three-quarters of its total displacement from its most forward position at about **113°** on the timing circle. By this time, the shed will be fully open, or nearly so.
- It is therefore, the position of the reed rather than the timing of shedding that determines the earliest time for the shuttle to enter the shed. **In practice, it may be permissible for it to enter a little earlier, say between 105 and 100°.**

- The latest time for the shuttle to come to rest in the shuttle box on the opposite side of the loom, is determined by the fast-reed warp-protector motion.
- Now, if the shuttle does not arrive in time owing to some disturbances the loom must be stopped at 270° at the latest in order to prevent a shuttle trap.
- Hence, when the loom is running normally, the latest time for the shuttle to contact the swell will be about 250° .
- The time available for the passage of the shuttle through the shed is therefore about $250 - 110 = 140^{\circ}$.

Relationship between loom speed and weft carrier velocity and picking angle

- There is a simple numerical relation between the loom speed, the distance traveled by the weft carrier through the shed, the degrees of crankshaft rotation available for its passage, and the average velocity of the shuttle during its passage.
 - n is the loom speed in ppm,
 - θ is the angular crankshaft rotation available for weft carrier traverse in degrees,
 - v is the average shuttle velocity (m/s),
 - K_b is the reed-space (m), and L_s is the weft carrier length (m).
 - T is time in seconds of a weaving cycle, t is time in seconds available for weft carrier passage.
 - s is the carrier path.

Loom speed and weft carrier velocity

- Then, if t is the time in seconds available for its passage:

$$t = \frac{60}{n} \times \frac{\theta}{360} = \frac{\theta}{6n}$$

$$v = \frac{s}{t} = \frac{(K_b + L_s)6n}{\theta}$$

Thus, the practical loom speed as:
$$n = \frac{1}{6} \cdot \frac{\theta \cdot v}{K_b + L_s}$$

Suppose that the maximum tolerable value for the average shuttle speed in a loom with an effective reed-space of 1.15 m is 13.75 m/s, that 135° of crankshaft rotation can be allowed for the passage of the shuttle, and that the effective length of the shuttle is 0.30 m, then the maximum permissible loom speed will be:

$$n = \frac{13.75 \times 135}{6(1.15 + 0.30)} = 213 \text{ picks/min}$$

Loom speed and weft carrier velocity

- For a given width of loom and length of shuttle, the denominator in the equation is constant, in which case we may write $n \propto v\theta$
- Thus, if we wish to increase the loom speed, we must increase the shuttle velocity or the fraction of the loom-cycle available for its passage or both.

Power required for picking

- The kinetic energy of the weft carrier when it leaves the picker:

$$\text{energy/pick} = \frac{mv^2}{2} \quad \text{J}$$

where m is the mass of the shuttle in kg, and v is the maximum velocity in m/s. Then the power for picking:

$$\text{power for picking} = \frac{mv^2}{2} \times \frac{n}{60} \times \frac{1}{1000} \quad \text{kW}$$

If v is now the average speed of the shuttle during its passage through the shed,

$$v = \frac{s}{t} = \frac{(K_b + L_s)6n}{\theta} \quad (\text{m/s})$$

Power required for picking

- For a given width of loom, the power usefully employed for picking is proportional to the cube of the loom speed.
- The energy consumed per pick, and therefore the cost of energy usefully employed for picking per unit of production, increase only as the square of the loom speed.

work done/pick

$$= \frac{mv^2}{2} = \frac{18mn^2(K_b + L_s)^2}{\theta^2} \quad \text{J}$$

power for picking

$$= \frac{mv^2}{2} \times \frac{n}{60} \times \frac{1}{1000} = \frac{3mn^3(K_b + L_s)^2 \cdot 10^{-4}}{\theta^2}$$

kW

Weft insertion with projectile

- Only one projectile weaving machine had achieved significant commercial penetration although many attempts had been made.
- Those attempts had never offered a serious competition to the Sulzer projectile machine operating on the Rossmann patents, based on unilateral picking of multiple projectiles.
- The projected carrier mass is ten times lower than that of the shuttle weaving machine. Due to this,
 - Higher picking speeds may be used but the kinetic energy, which is equal to the picking work, is lower.
 - A higher acceleration and a shorter acceleration path may be used without the driving force exceeding acceptable limits.
 - Higher machine speeds are attainable.

Weft insertion with projectile

- The gripper projectile clamps the end of the weft thread and pulls the thread across the shed..
- Owing to the small diameter of the weft thread it is technically rather difficult to feed and clamp the end of it.
- It requires a high precision of the dimensions and performance of the feeding and clamping mechanisms.

Weft insertion with projectile

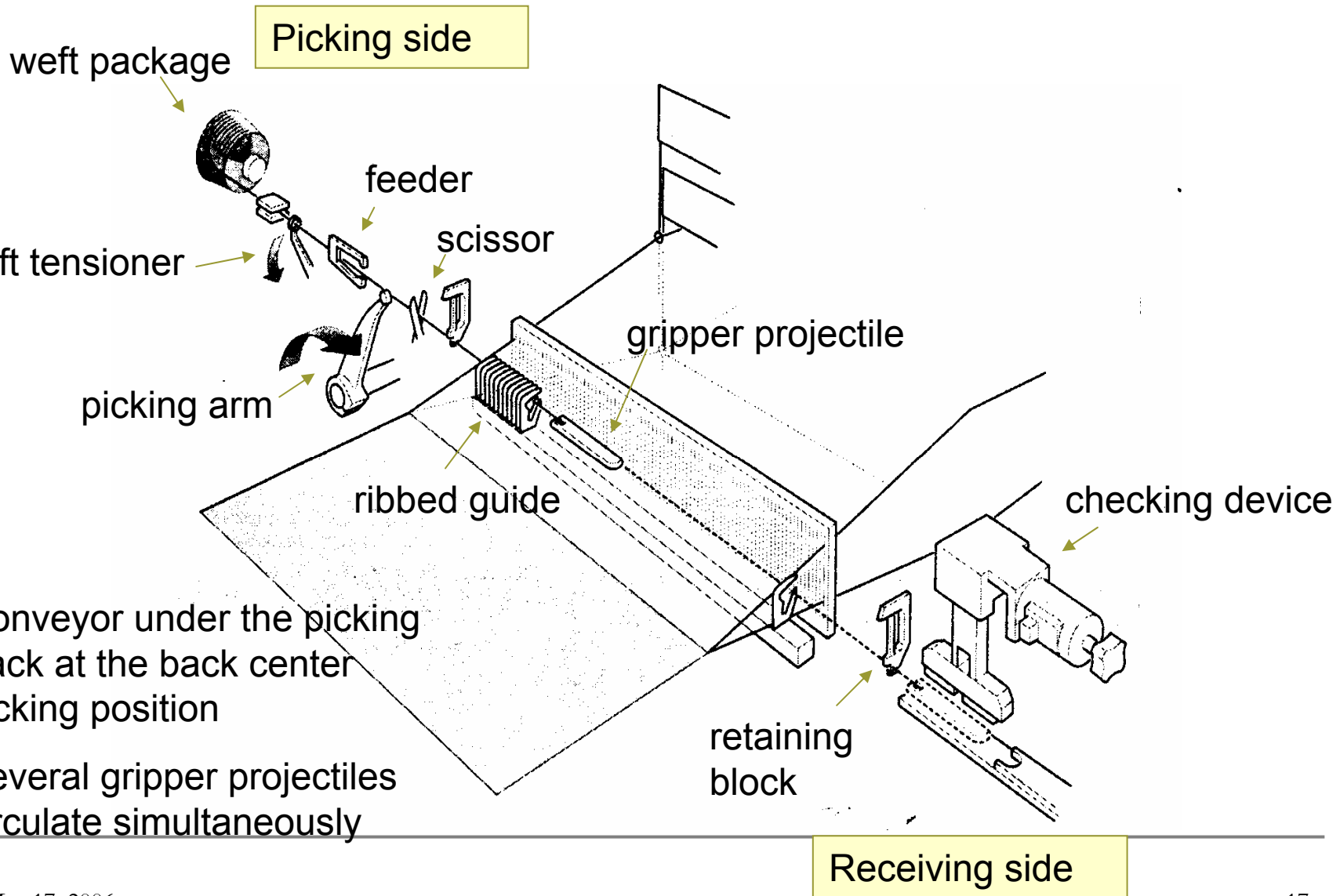

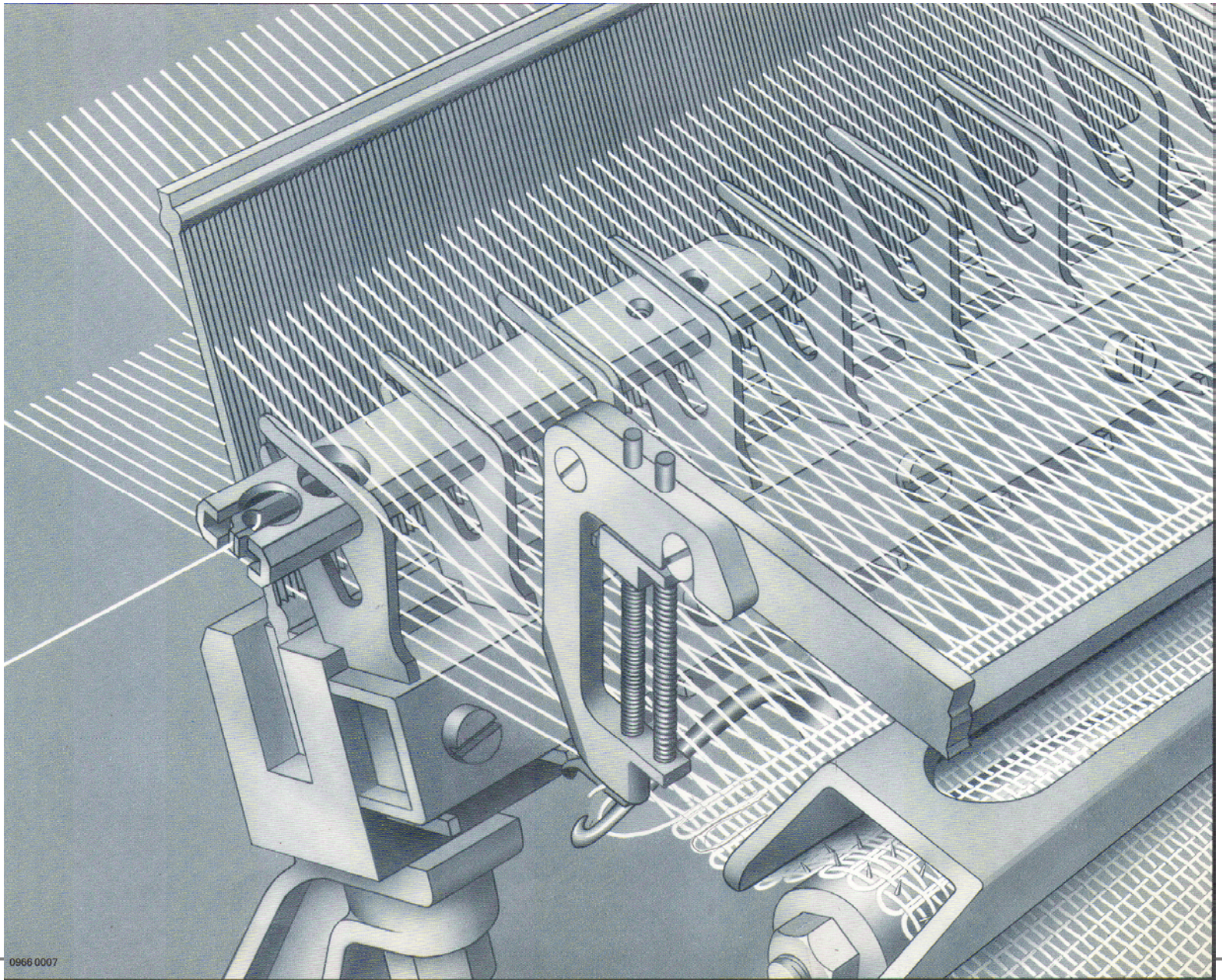

0966 0007

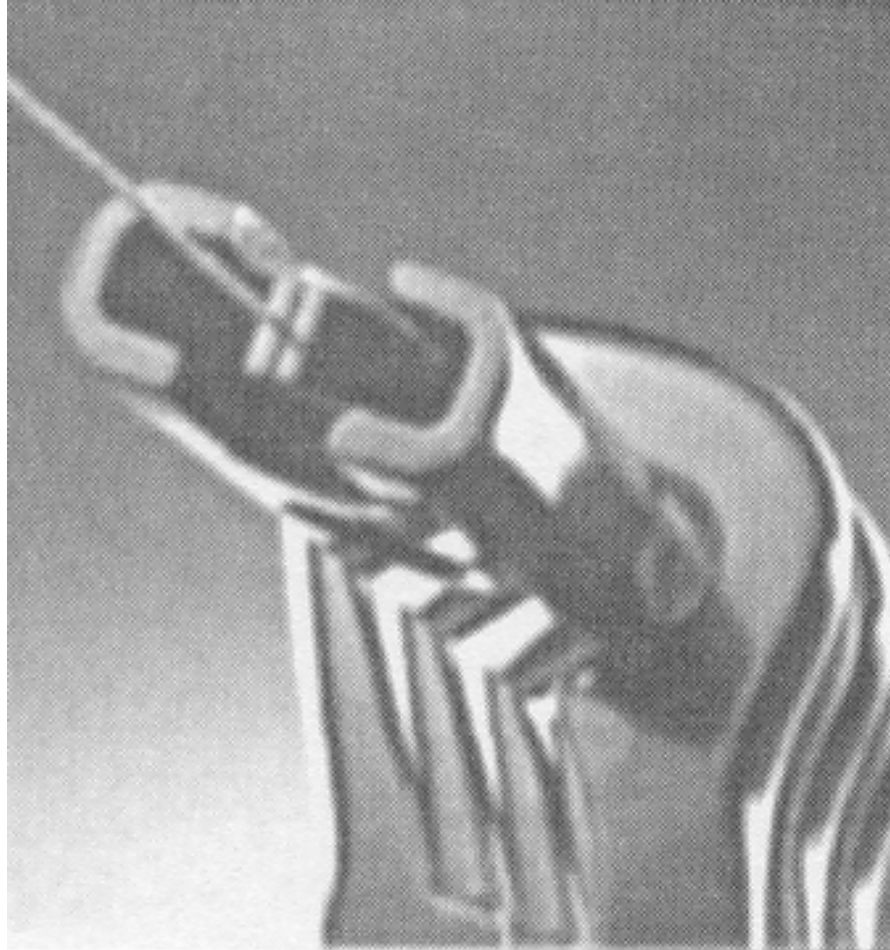

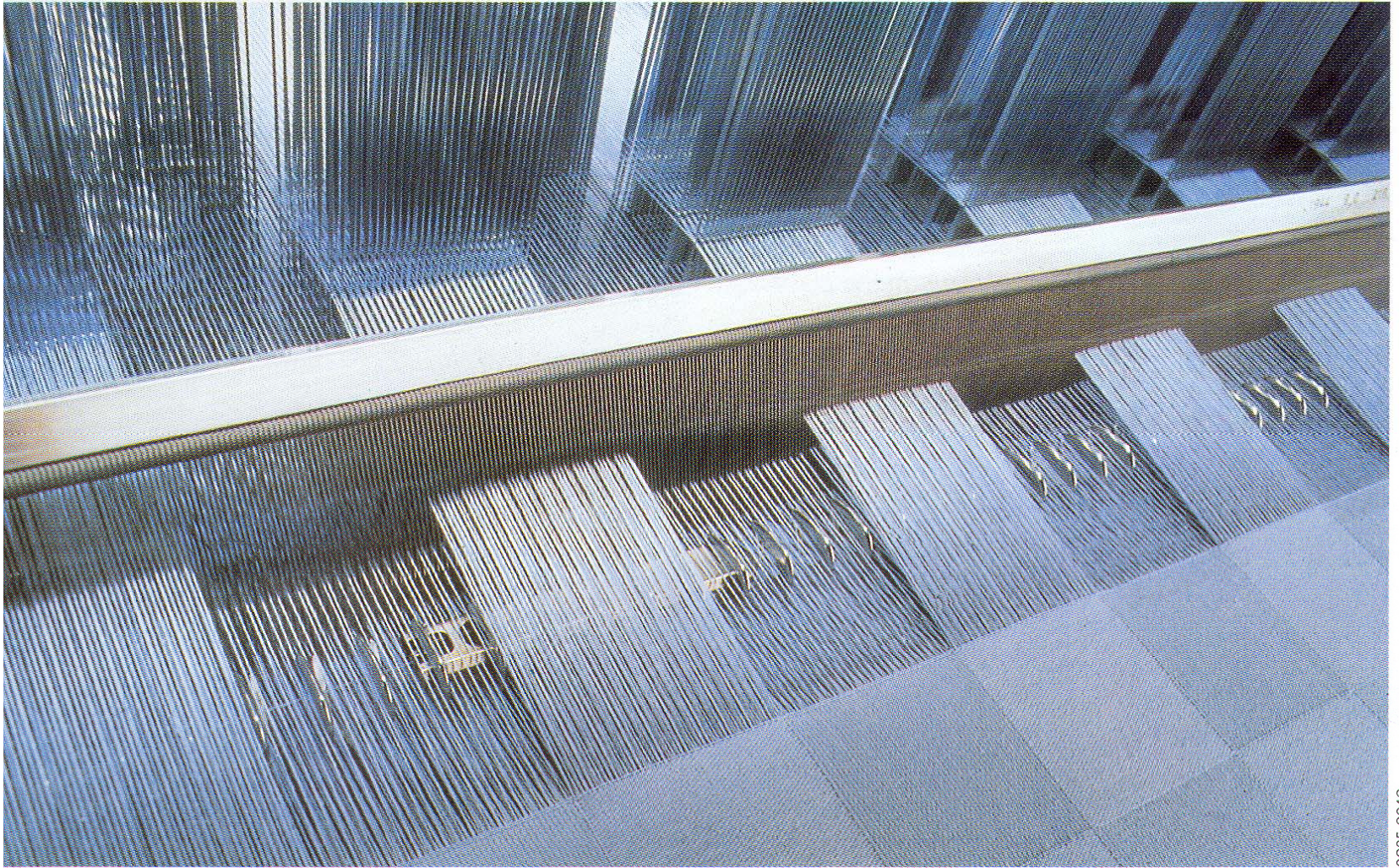

9095-0940

The picking mechanism: The torsion bar picking system of the machine

- A strain energy is developed by twisting the torsion bar and released suddenly to transfer the maximum possible strain-energy to the projectile before the projectile leaves the picker-shoe.
- Projection velocity of the weft carrier can be increased
 - by increasing the angle of twist or
 - by maintaining the same angle of twist on a larger diameter rod

Torsion mechanism before picking

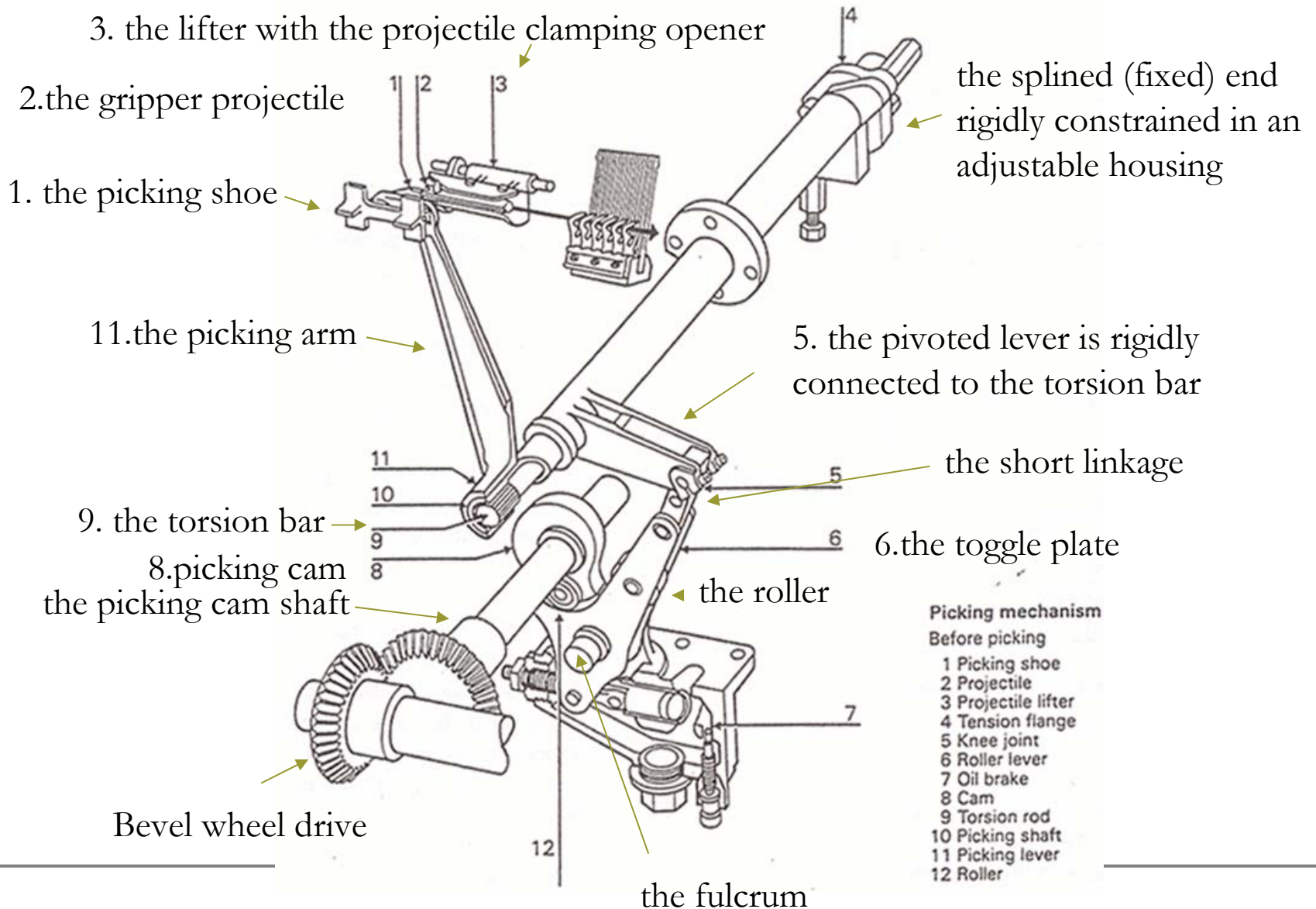

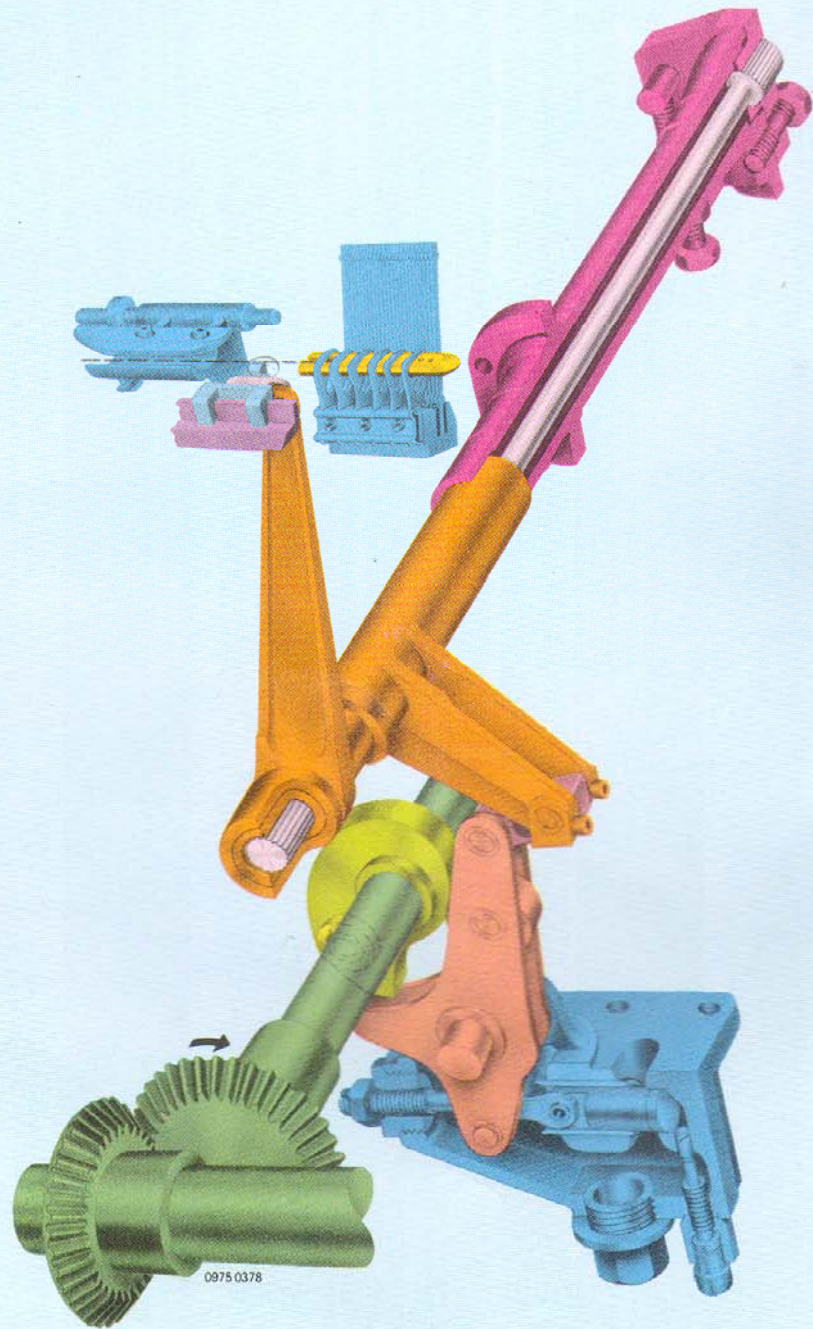
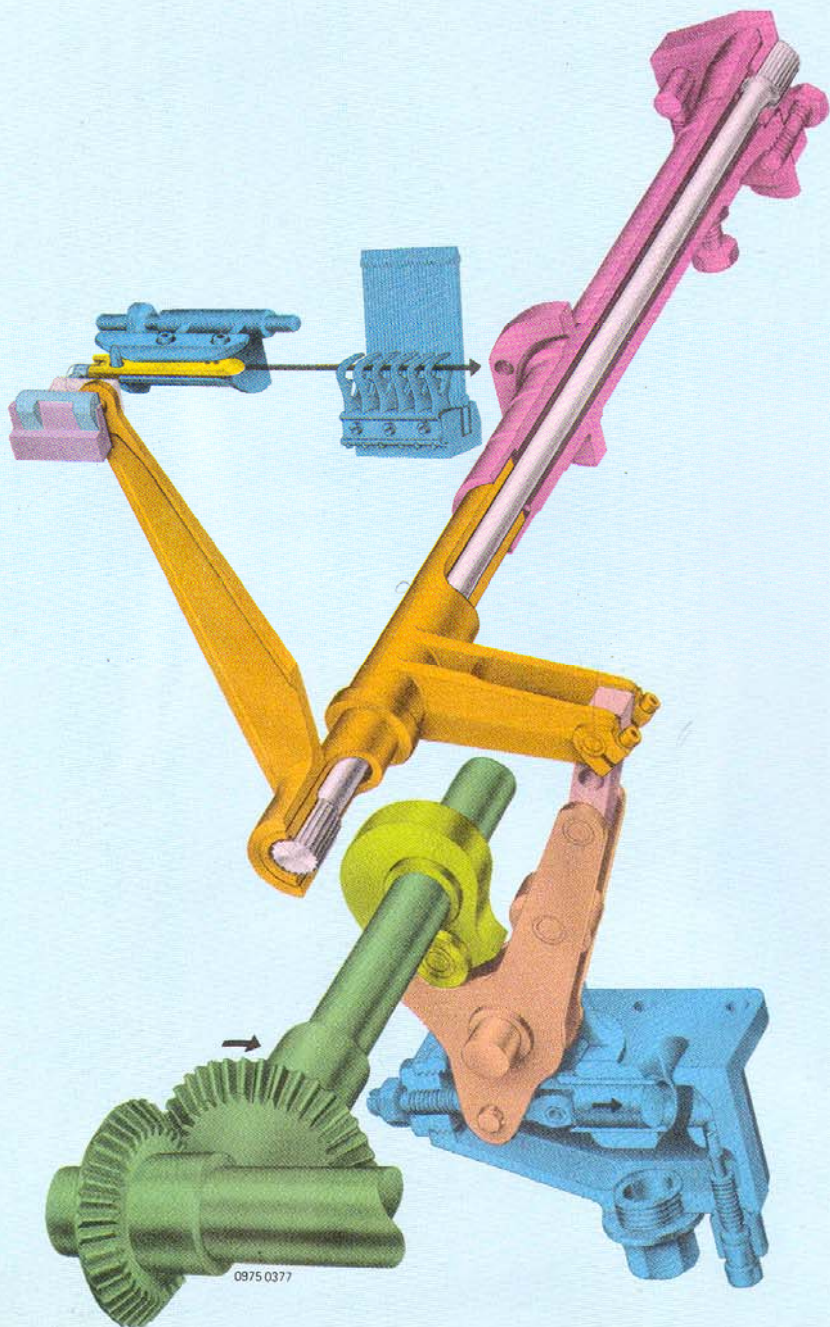

Torsion mechanism before picking

- The picking cam shaft rotates once every pick, drives the picking cam, which is similar in shape to that used in a shuttle picking, but rotates clockwise.
- At the beginning of picking, it gradually displaces the roller and turns the toggle lever in the clockwise direction about its fulcrum, thus withdrawing the picking-shoe to its rearmost position.
- In doing so, it has twisted the free end of the torsion rod through the short link and the torsion lever, which is secured to the torsion rod near its free end.
- In this position the three centers of the toggle arrangement are in line and the torsion bar is twisted to its predetermined angle which is about 30° , and the picking arm has rotated through a similar angle.
- The mechanism is now fully stressed.

Torsion mechanism before picking

The mechanism is now fully stressed.

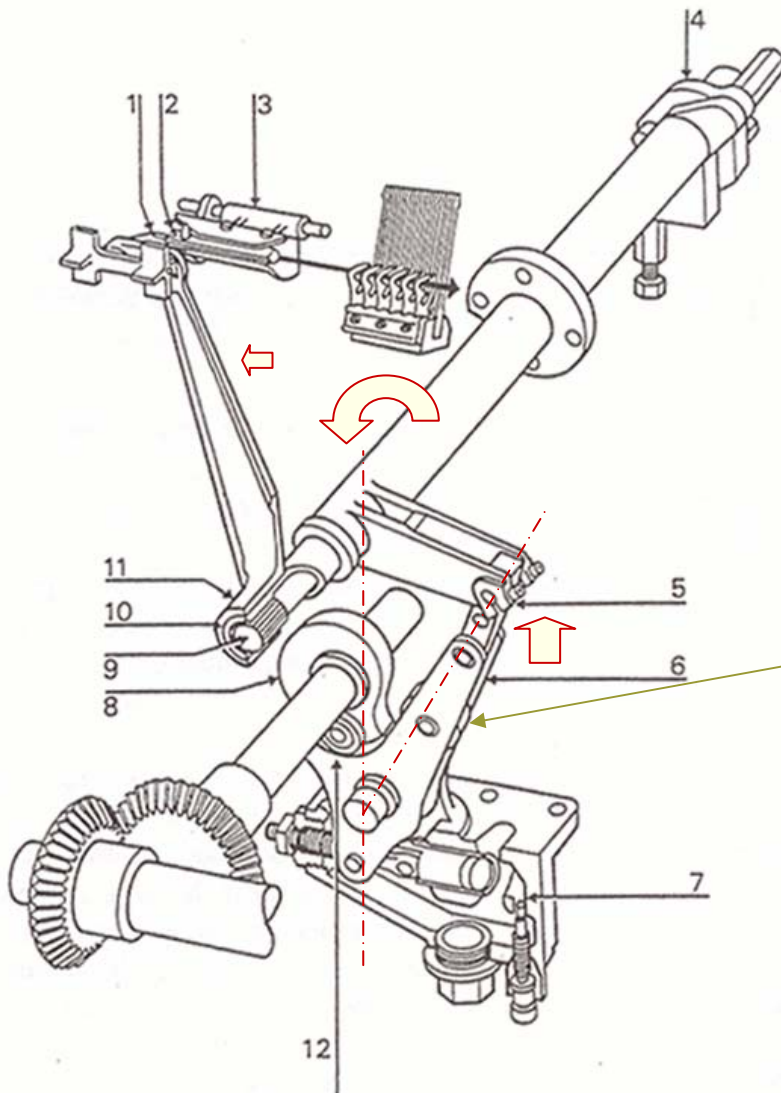

As the picking cam continues to turn, the roller will lose contact with the nose of the cam, but this will not release the torsion because the axis of the link passed to the right of the axis of the fulcrum .

Picking mechanism

Before picking

- 1 Picking shoe
- 2 Projectile
- 3 Projectile lifter
- 4 Tension flange
- 5 Knee joint
- 6 Roller lever
- 7 Oil brake
- 8 Cam
- 9 Torsion rod
- 10 Picking shaft
- 11 Picking lever
- 12 Roller

Torsion mechanism after picking

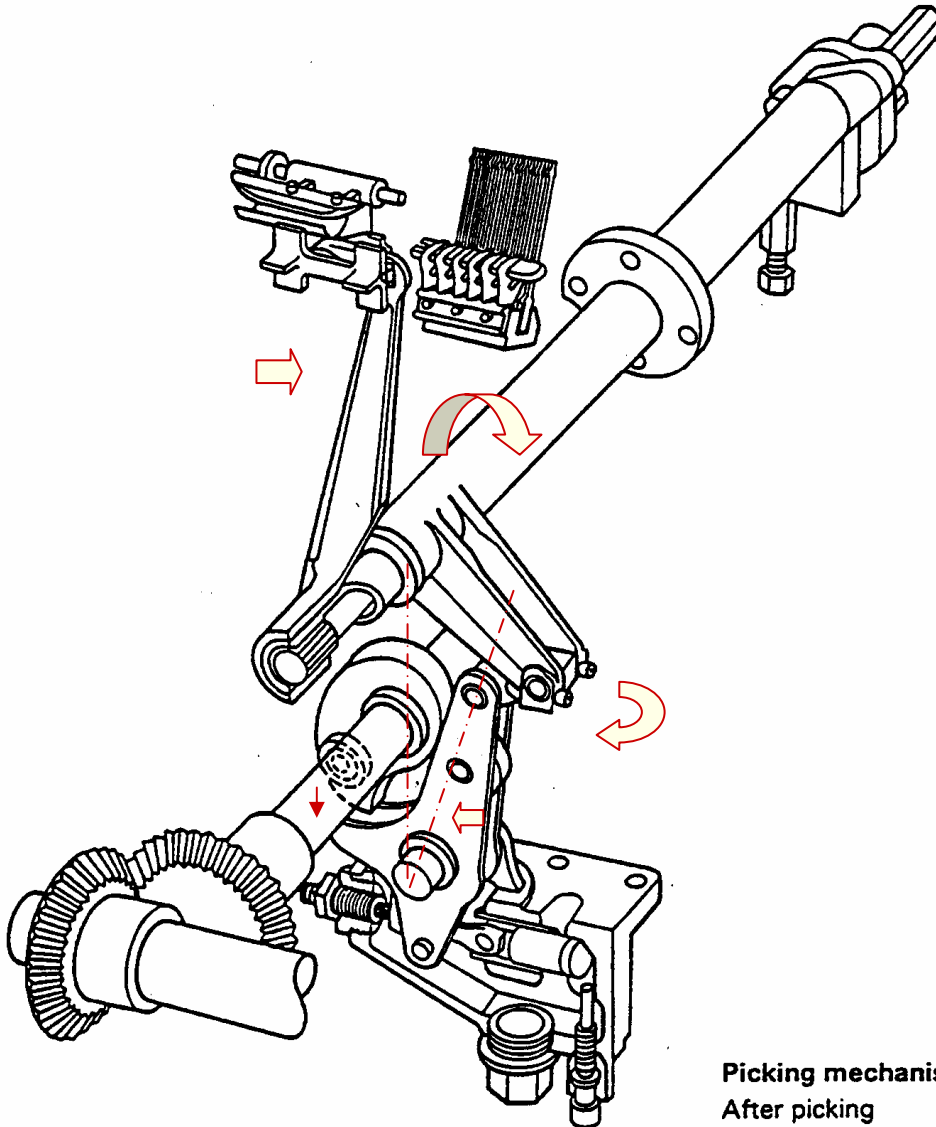

Picking mechanism
After picking

- Some time after another roller, which is fixed to the picking cam, turns the toggle lever slightly anti-clockwise by depressing its curved contour.
- As soon as this movement brings the axis of the link slightly to the left of the axis of the fulcrum of the toggle lever.
- The system collapses, and the torsion is practically instantaneously released, thus permitting the strain energy in the rod to be transmitted instantaneously to the projectile.

Projection /picking

- The picker accelerates the projectile over a distance of about 65 mm in 0.007s.
- The energy utilization of the projectile system is not much more efficient than that of shuttle projection and all other weaving machines are less efficient.
- The residual energy in the picking system, some 62% of the whole, is absorbed in the hydraulic buffer, the body and plunger.
- The picker and the rest of the lever system are then brought to rest over the next 40 mm of picker movement by the oil brake.
- The speed of the projectile as it leaves the picker is normally about 24.4 m/s.



Velocity-Acceleration

Acceleration is far from uniform and reaches a peak value of 6630 m/s^2 when the projectile has traveled nearly 15 mm . The peak deceleration has a value of 9920 m/s^2 and occurs about 12.5 mm before the picker comes to rest.

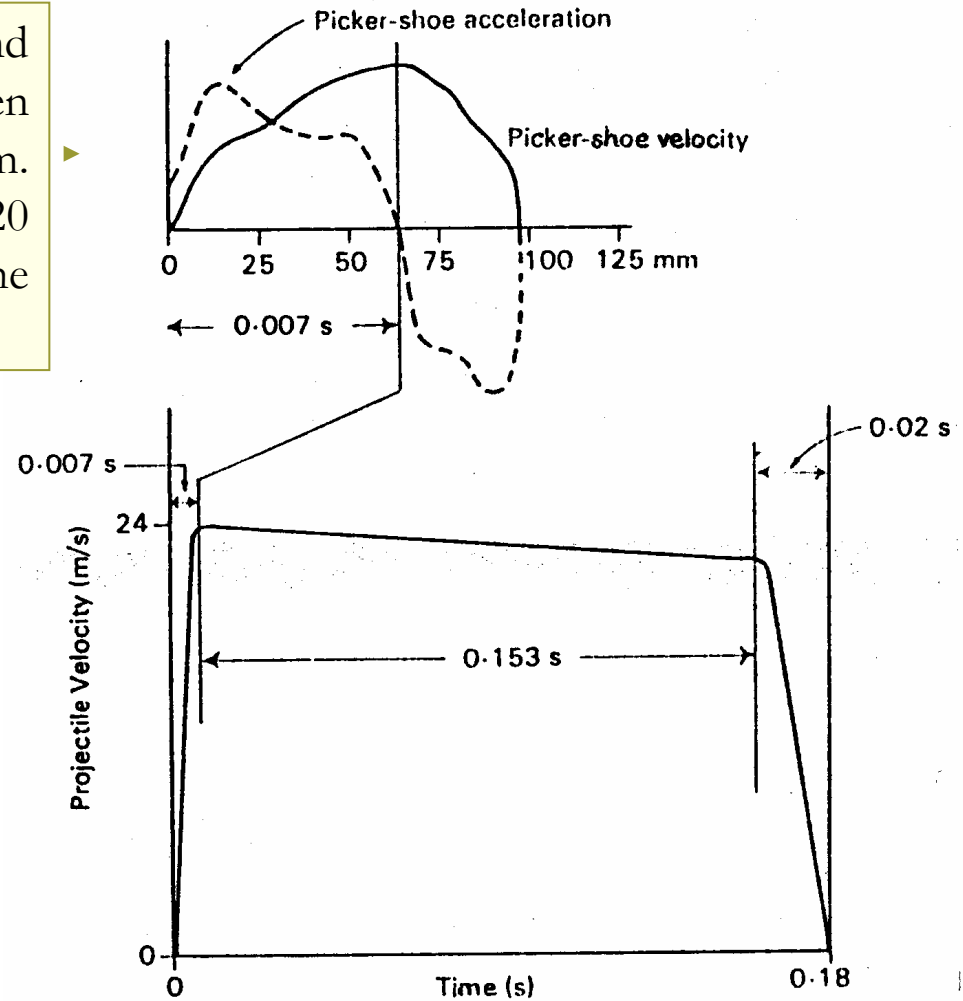

Velocity-Acceleration

- Acceleration of the projectile occupies 0.007 s.
- The velocity of the projectile varies during its acceleration, flight across the loom (the loss in the speed), and retardation to its rest position at the opposite side of the loom..
- Retardation occurs over a substantially longer time than acceleration and is therefore relatively gentle.
- The peak forces acting on the projectile are of the same order as those acting on the shuttle loom because the projectile has a mass of less than 40 g.
- This gives a peak accelerating force of about 262.5 N and a peak retarding force of about 397 N.

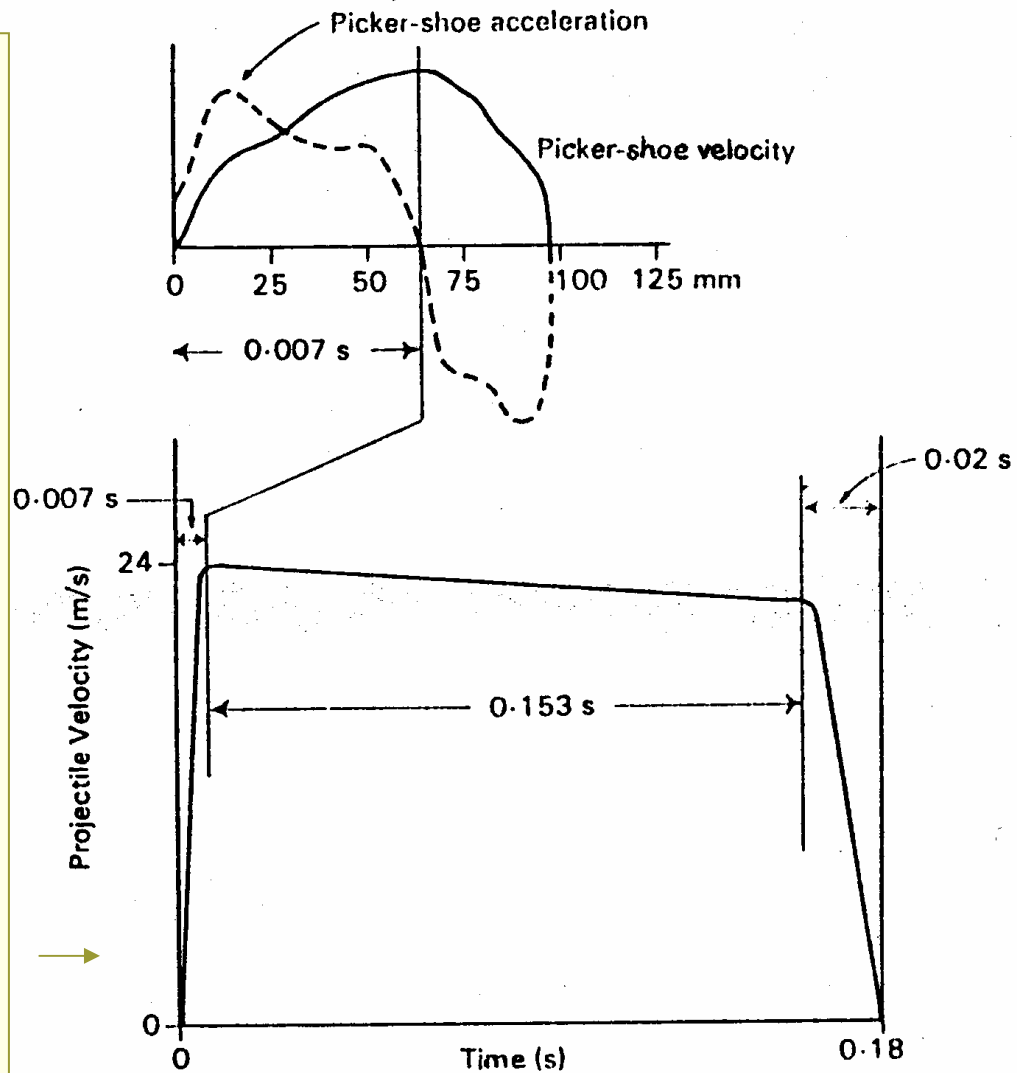

The picking mechanism: The torsion bar picking system of the machine

- The formula for the axial twisting of circular rods is:

$$T = \frac{CJ\theta}{l}$$

where T is the torque applied, C is the modulus of rigidity of the bar material, J is the polar second moment of area of the rod section, θ is the twisting angle in radians, l is the twisting length, and r is the radius of the rod.

The polar second moment for a circular section (J) is $\frac{\pi d^4}{32}$. The work done in loading up the torsion bar is the area under the $T\theta$ curve,

$$\text{Work done} = \frac{T\theta}{2} = \frac{CJ\theta^2}{2l}$$

Torsion bar used on 330cm machines

The twisting length is 28.4in(72.14 cm) and angular displacement at commencement of picking is considered as normal at 28° .

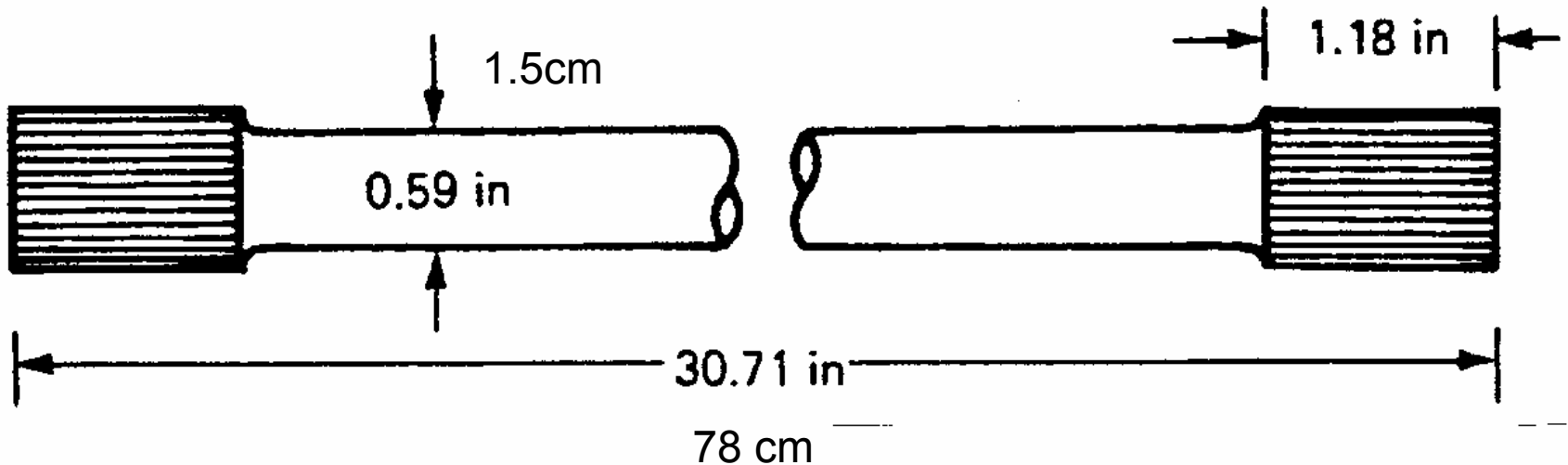

The picking mechanism: The torsion bar picking system of the machine

- Applied torque is 25.34kg.m units and the work done on the rod per pick is 7.62kg.m units.
- Only 14% of the work done in energizing the torsion bar is effectively transferred to the projectile inserting the weft.
- To achieve higher initial projection speeds the diameter of the torsion bar was increased from 15mm to 17mm, and more recently to 19mm in subsequent models.
- As the energy in the system varies as the fourth power of the torsion rod diameter, all else remaining equal, the increase from 17 to 19mm diameter will provide 56% more strain energy.

Weft Insertion System

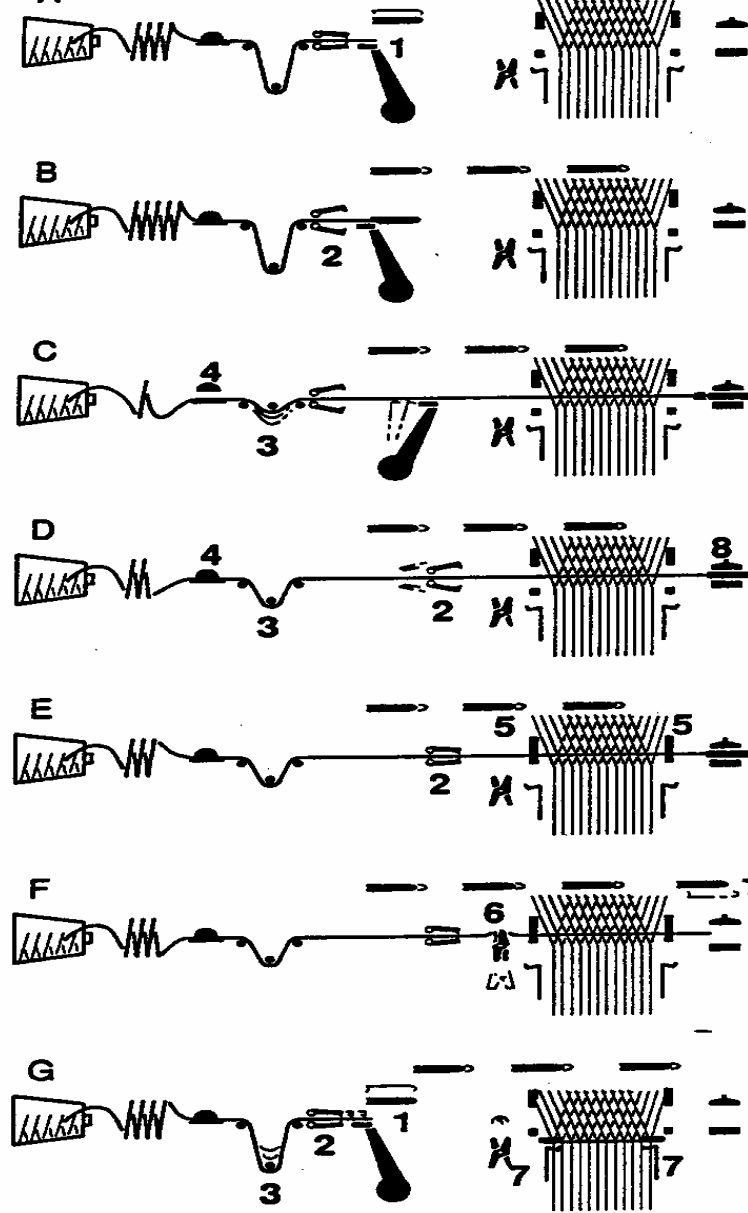

- 1 Projectile
- 2 Projectile feeder
- 3 Weft tensioner lever
- 4 Weft brake
- 5 Weft end gripper
- 6 Weft cutter
- 7 Tufting needles

Weft Insertion System

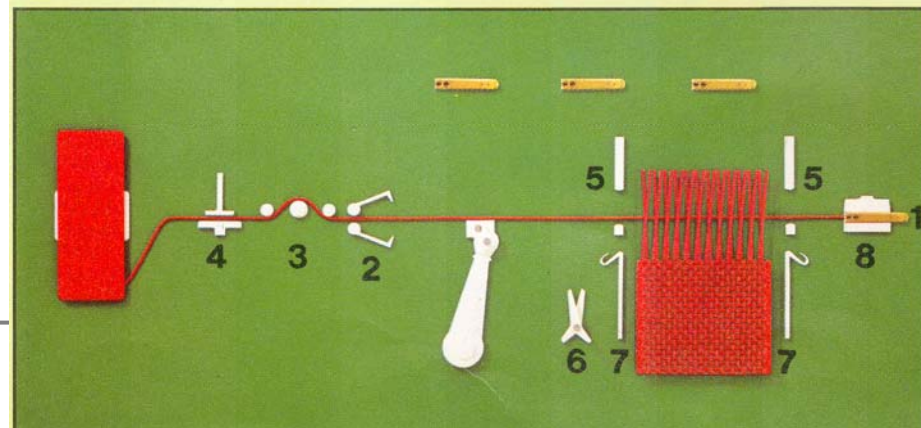
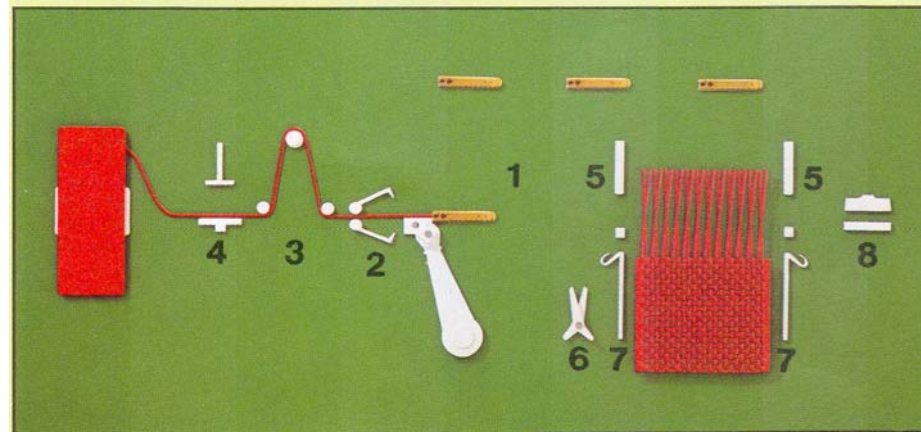
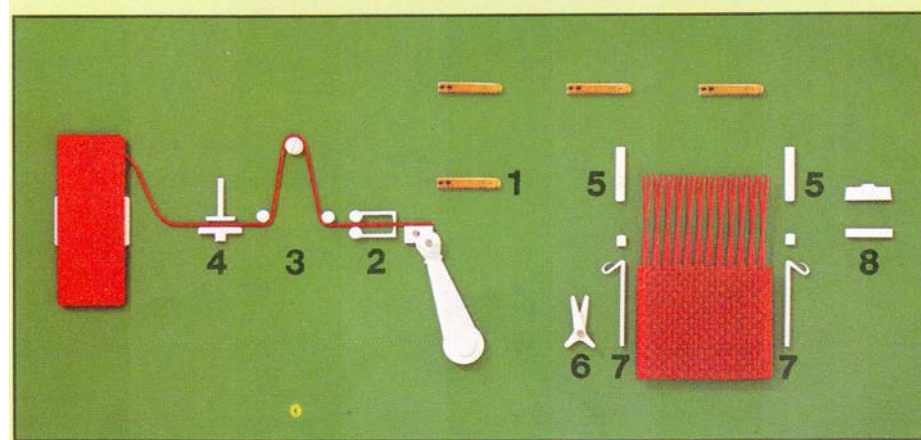

Weft Insertion System

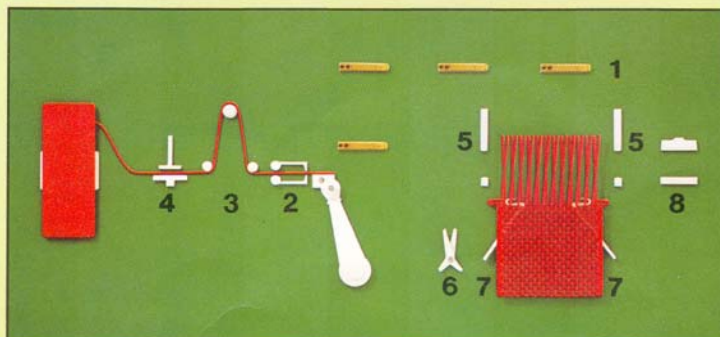
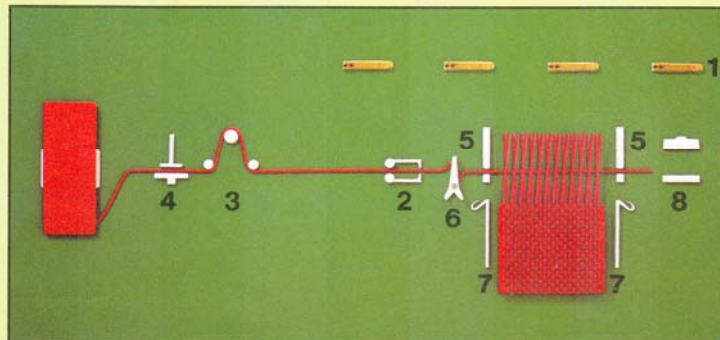
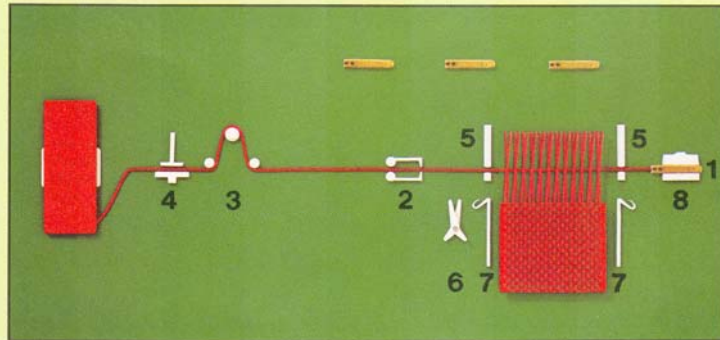
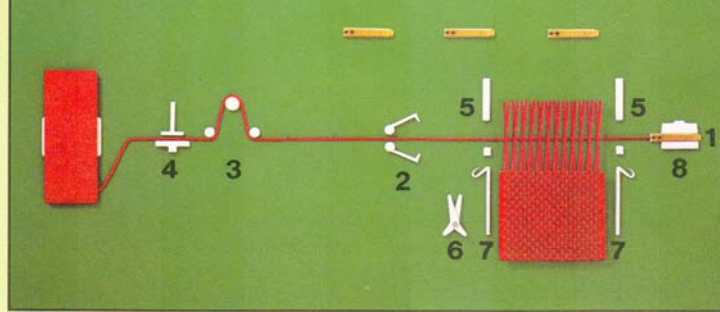

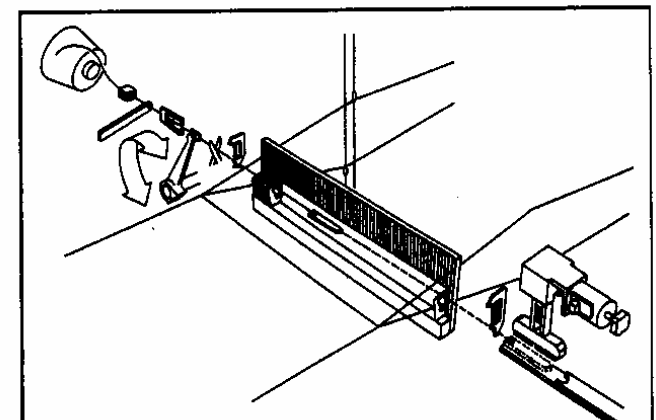
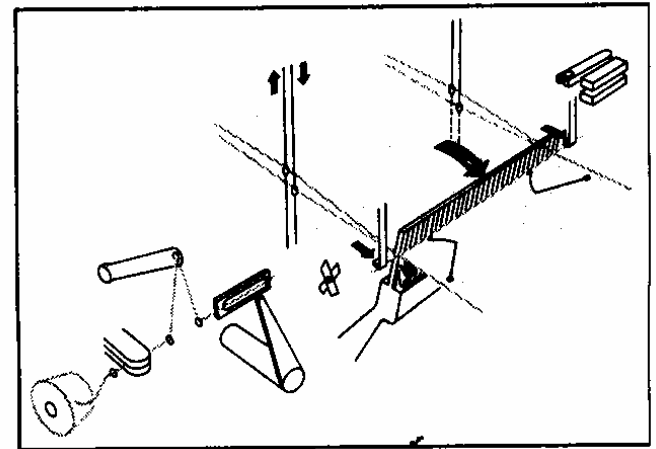
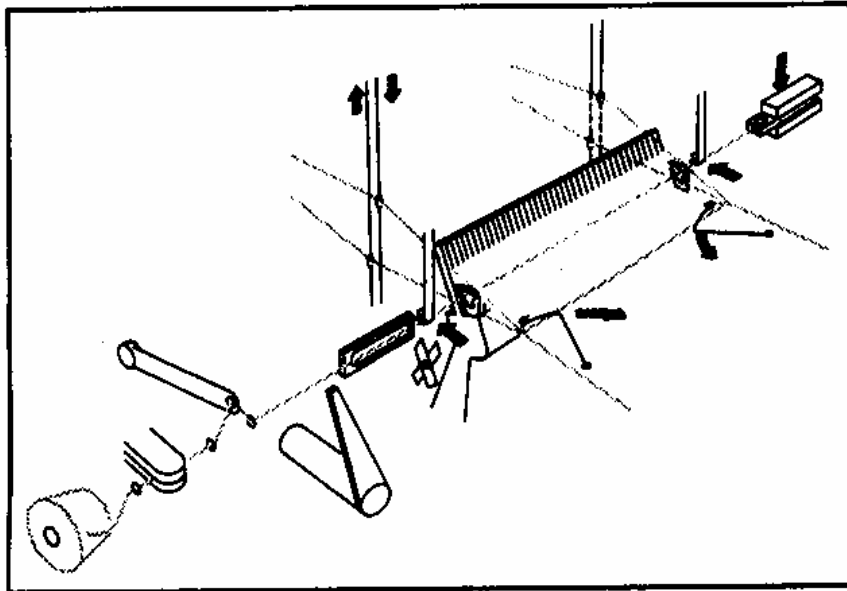
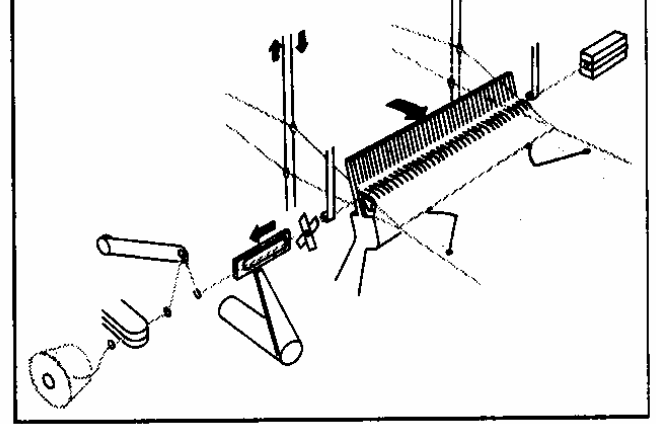
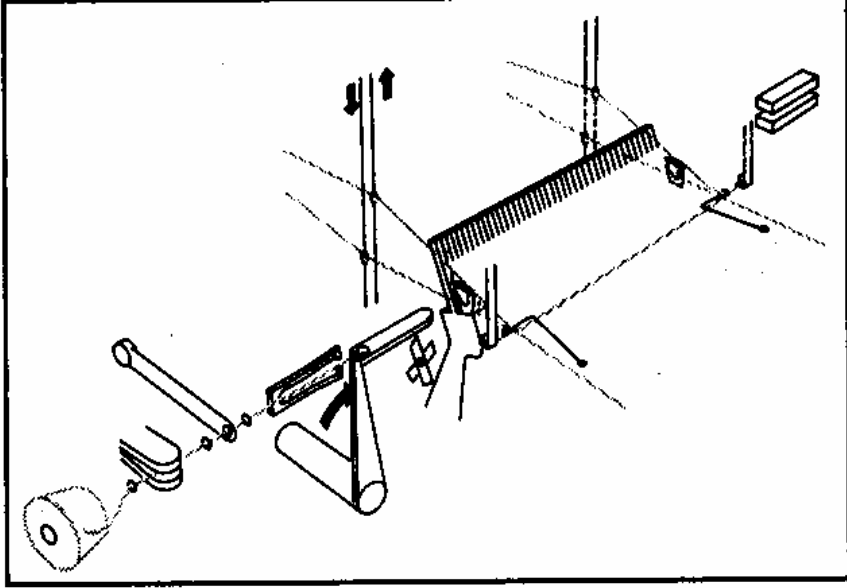

The gripper projectile

- The projectiles grip reliably a wide variety of threads, tapes or monofilaments and insert them in the shed.
- Reflecting the varying requirements for different weft yarns, projectile grippers with various clamping forces and surface areas are available.
- One outstanding feature of projectile technology is that the weft is inserted without central transfer, i.e. without additional acceleration and braking

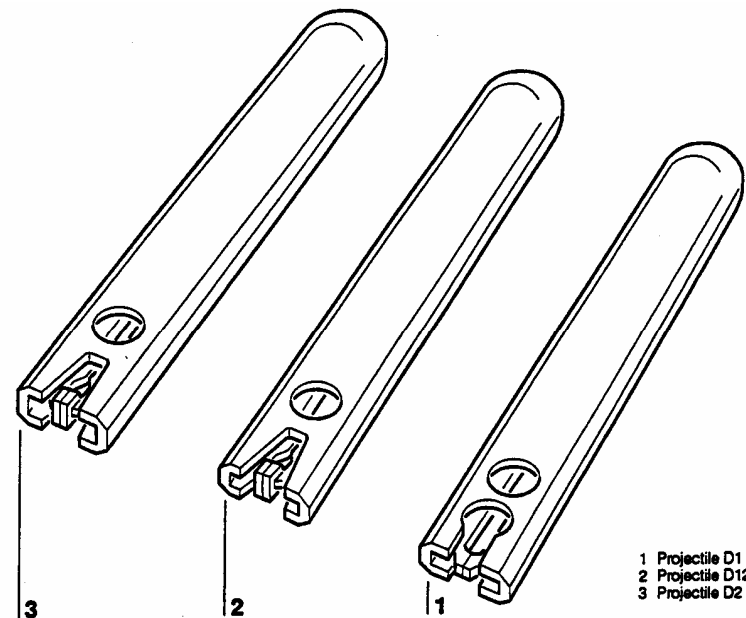
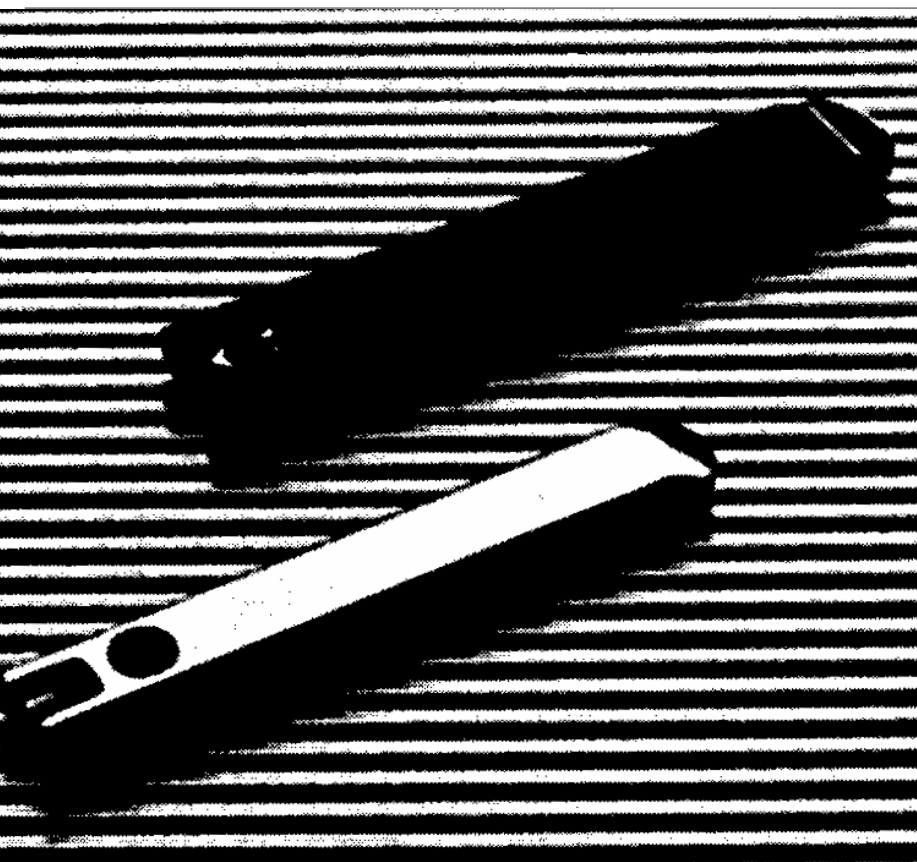

- 1 Projectile D1
- 2 Projectile D12
- 3 Projectile D2

	D1	D12	D2	K3
	<i>steel</i>	<i>steel</i>	<i>steel</i>	<i>composite</i>
Length (mm)	89	89	89	96
Width (mm)	14.3	14.3	15.8	18
Height (mm)	6.35	6.35	8.5	8

The gripper projectile

- In the standard type, the body of gripper projectile is of hardened and ground steel.
- The gripper is fitted in its cavity which is fixed with two rivets .
- In the rear part of the gripper projectile body there are two holes: one for the clamp opener, operating before the weft transmission, the other one for the clamp opener, operating after the delivery of weft and releasing the weft thread from the gripper projectile.
- Gripper is provided in its rear part with two jaws, whose clamping surfaces are of different character.
- Both jaws must be pre-stressed and interact with a minimal force, which is specified by the machine maker.
- The pre-stressing can be checked with a special gauge.
- For finer weft threads a plastic gripper projectile is available whose weight is as low as 17 g.

Application of projectile grippers

Projectile Grippers			D1	D1	D12	D2
<i>Clamping Force</i>	<i>Colour</i>	<i>Clamping Area (mm)</i>	<i>2,2 x 3</i>	<i>2,2 x 4</i>	<i>3,8 x 5</i>	<i>4 x 5</i>
600 g	violet	smooth	X			
1000 g	yellow	smooth	X			
1900 g	orange	smooth				
		with friction coating			X	X
2200 g	white	smooth	X	X	X	X
		with friction coating		X	X	X
		with groove	X	X	X	
		crisscross knurls		X	X	X
2500 g	blue	smooth			X	
		with friction coating			X	X
		with groove	X	X	X	
		crisscross knurls	X	X	X	X

Projectile jaws

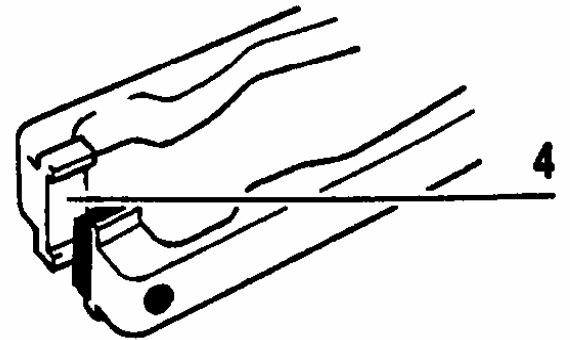
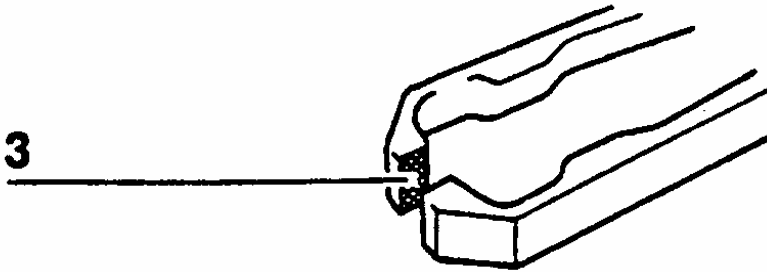
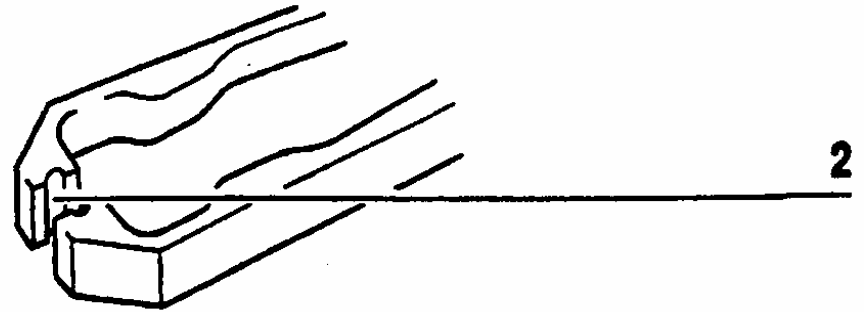
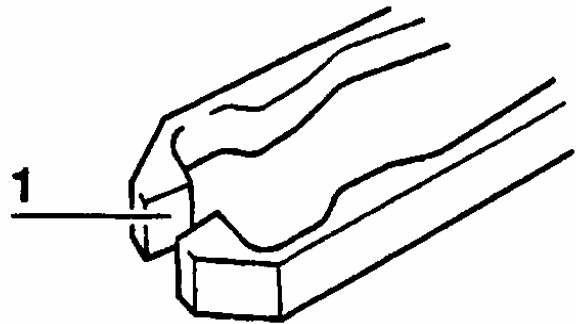

- 1 Smooth
- 2 With groove
- 3 Crisscross knurls
- 4 With friction coating and lateral guidance

The ribbed tunnel

- The gripper projectile has a low weight and could be easily deflected from its path.
- To avoid this, the gripper projectile is guided through a ribbed tunnel whose ribs lie between the warp ends during picking.
- The guide ribs must be as thin as possible so as not to restrict the warp density.
- They must be rigid enough so that the flying projectile is not braked by the rib oscillation.
- The rib density should be, by experience, such that the gripper projectile extends across four ribs at least.

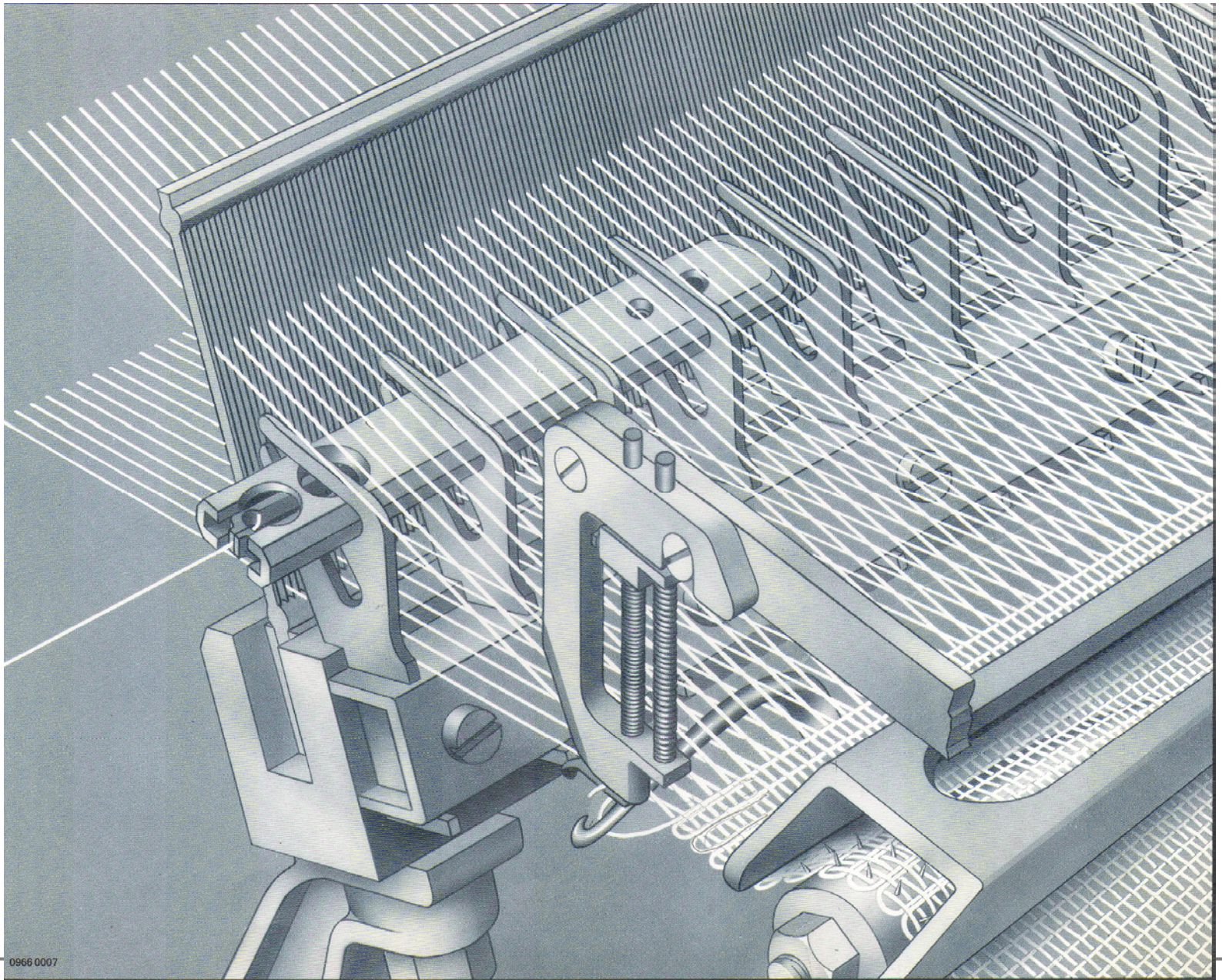

0966 0007

Guide teeth

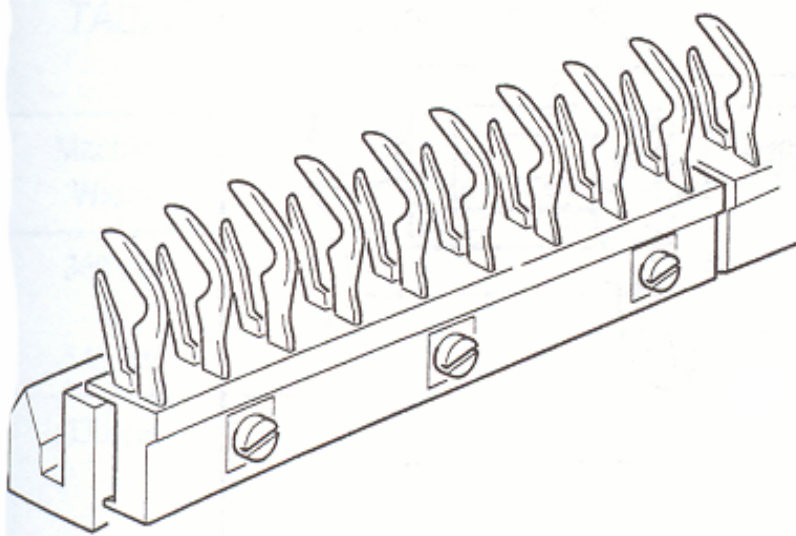

Aligned guide teeth D1-D12-D2

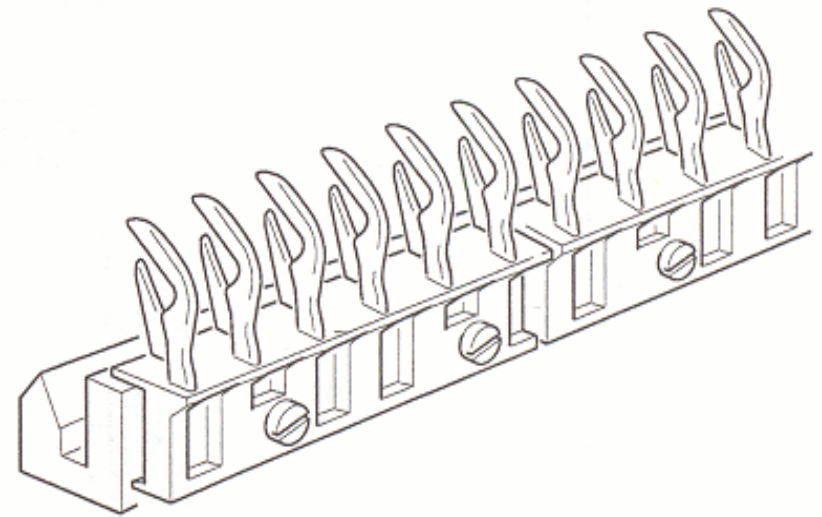



Staggered guide teeth D1-D12-D2

- The ribs must open towards the reed, thus providing a gap, through which the weft slide out before being beaten up to the fabric. The reed is at rest during picking.

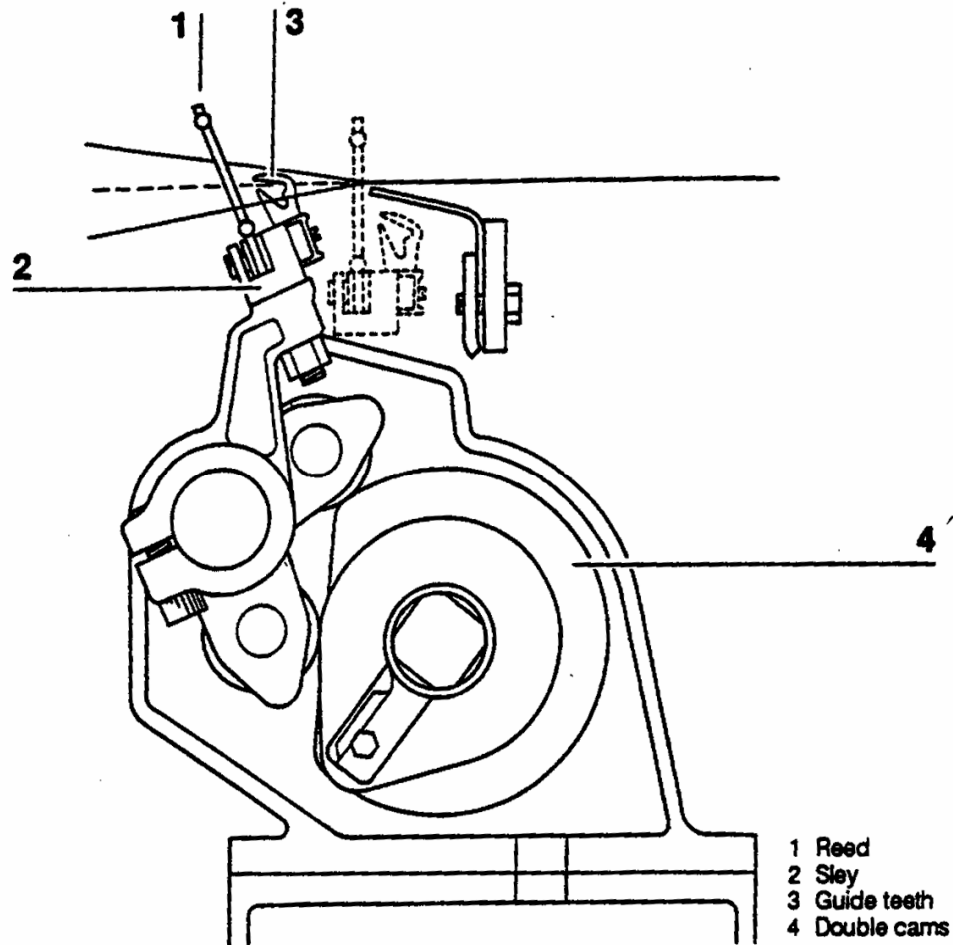
Sley

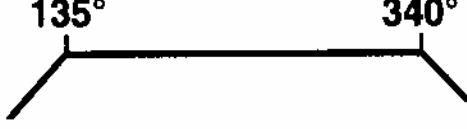
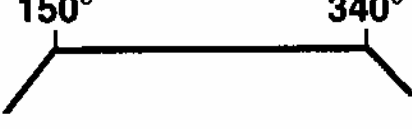

Machine Width	Sley Dwell
360 cm to 540 cm	
330 cm	
280 cm	
190 cm and 220 cm	

Preparation for picking

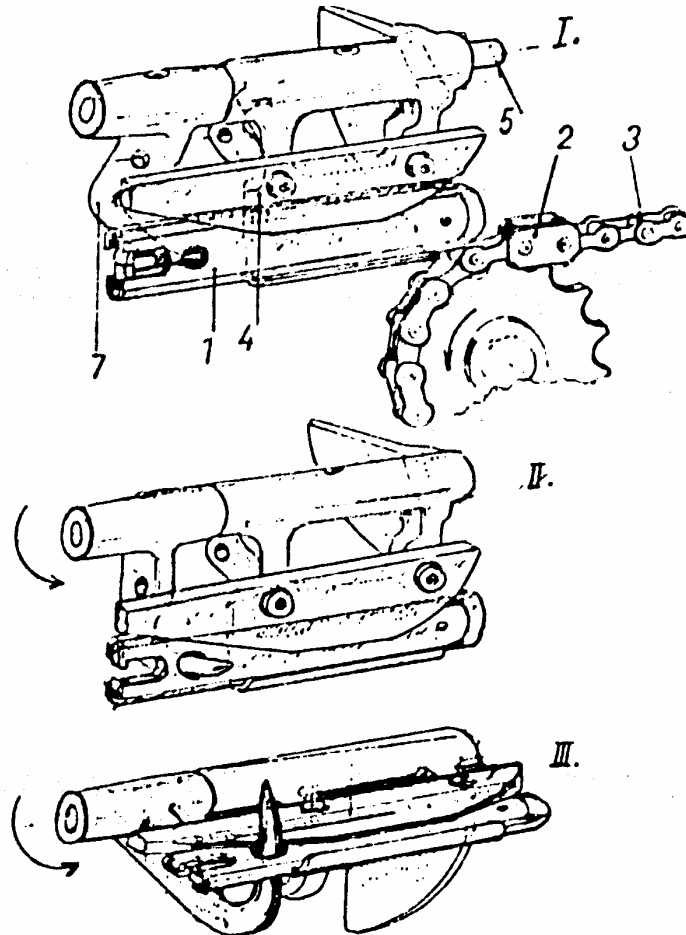

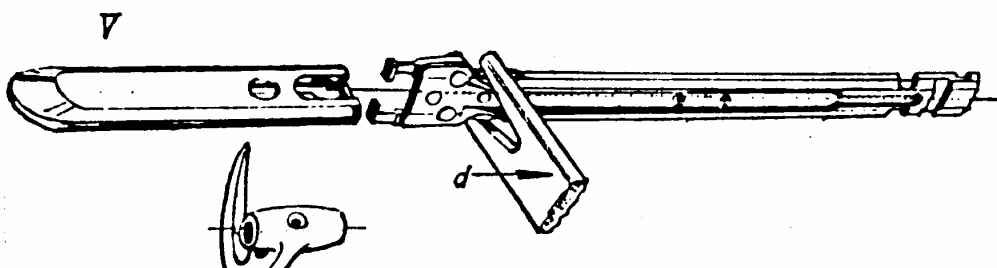
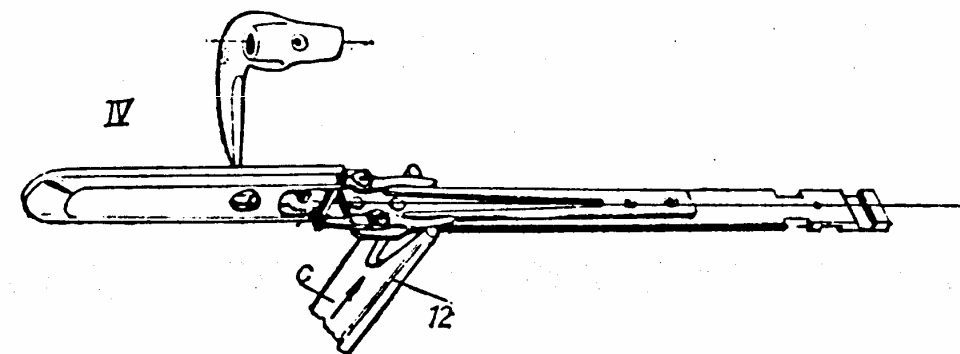
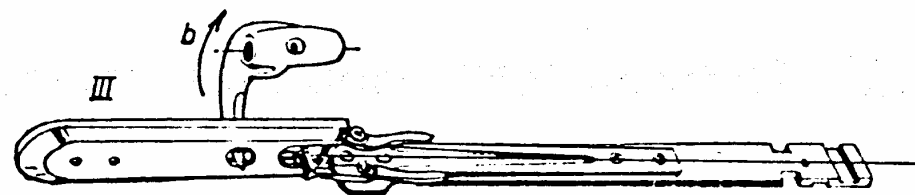
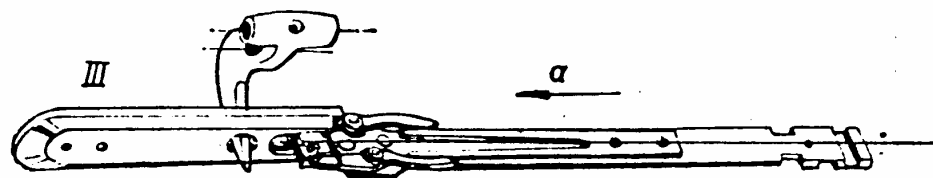
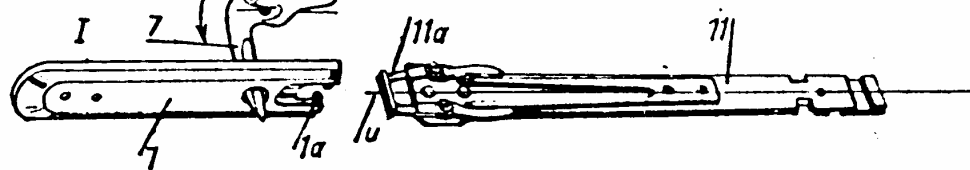

Color change at thread transfer

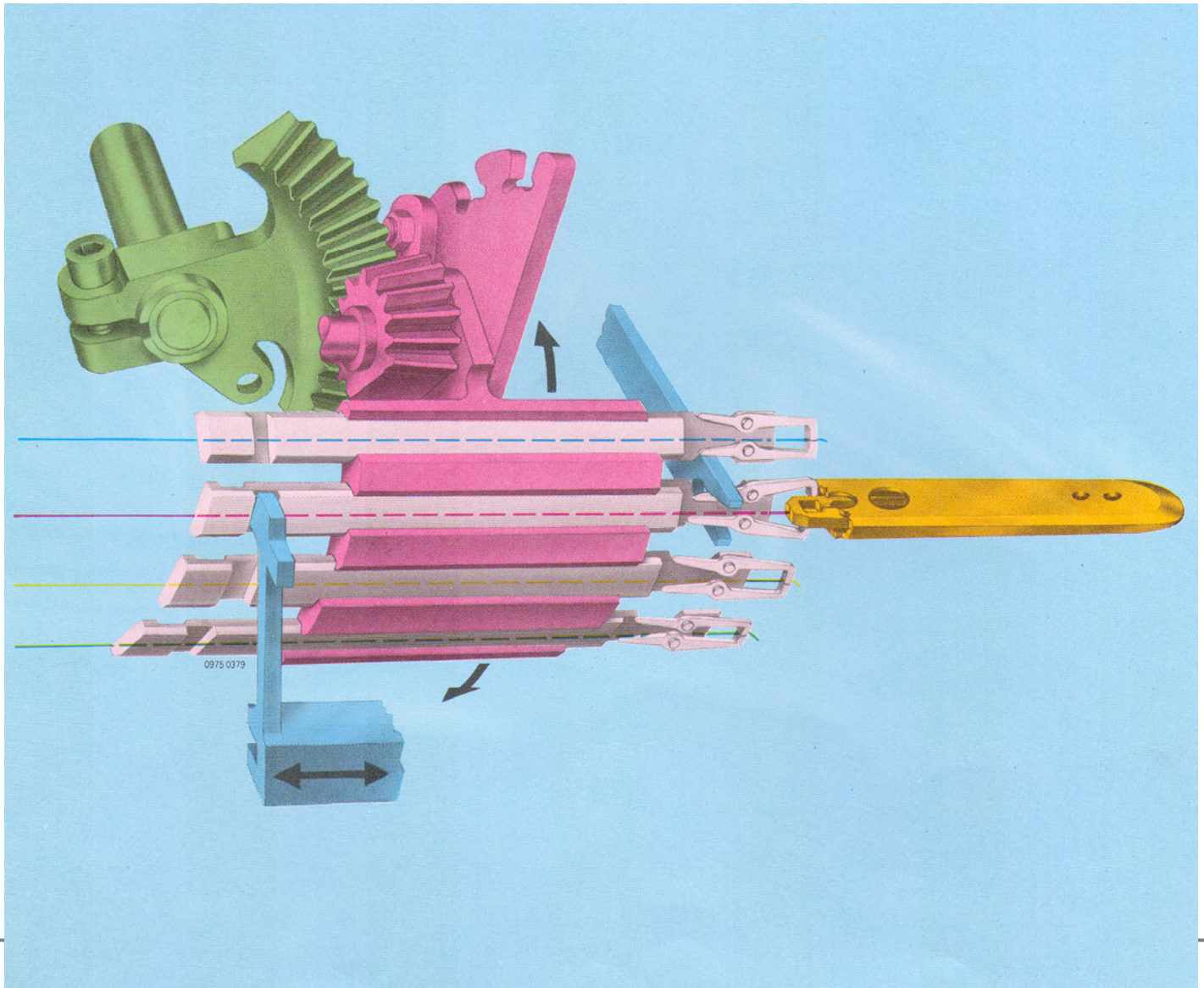

Color change at thread transfer

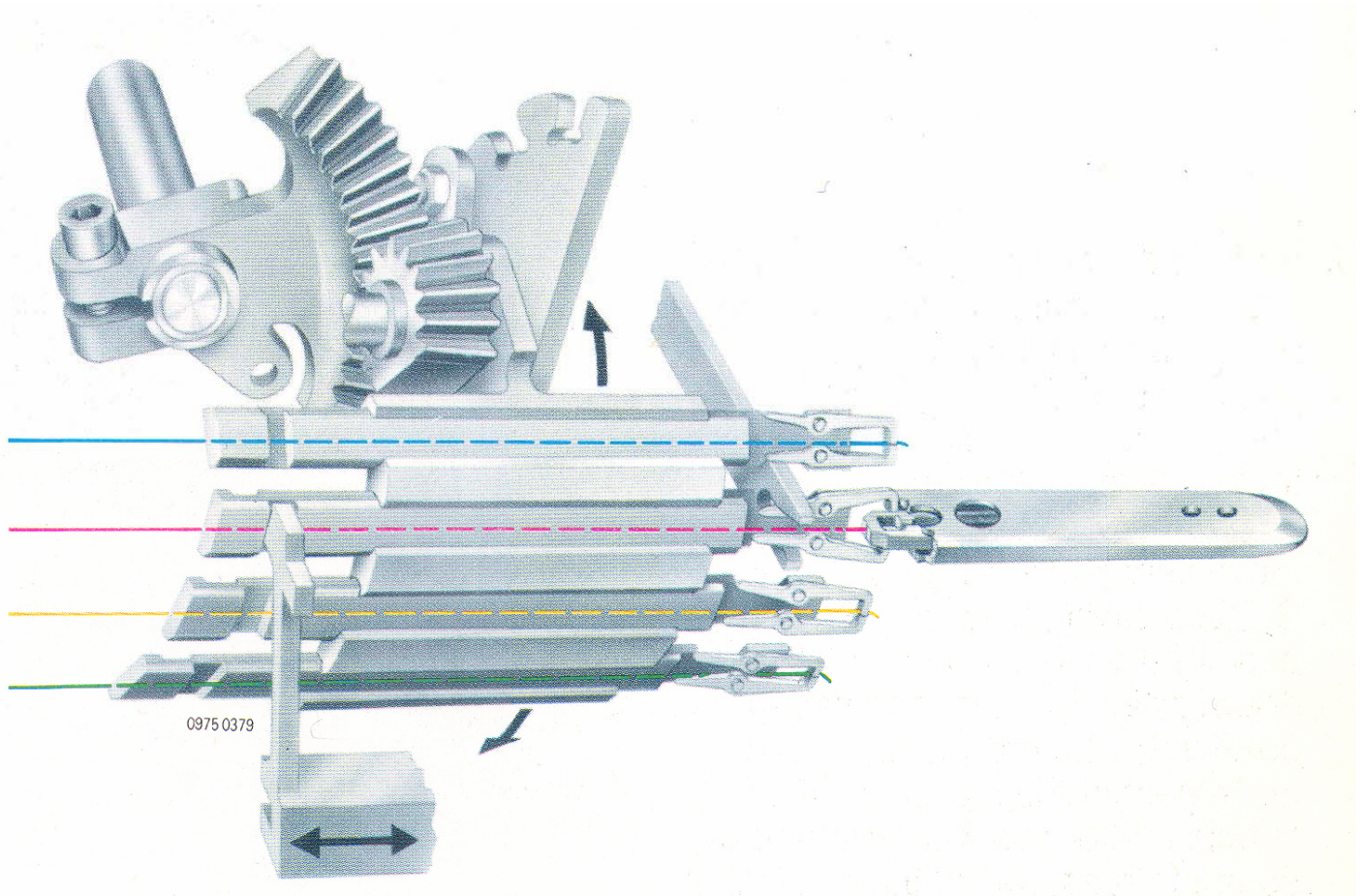

Original feeder and projectile grippers: Optionally, the P7300hp projectile weaving machine can be equipped with a control system for two, four or six weft colors.

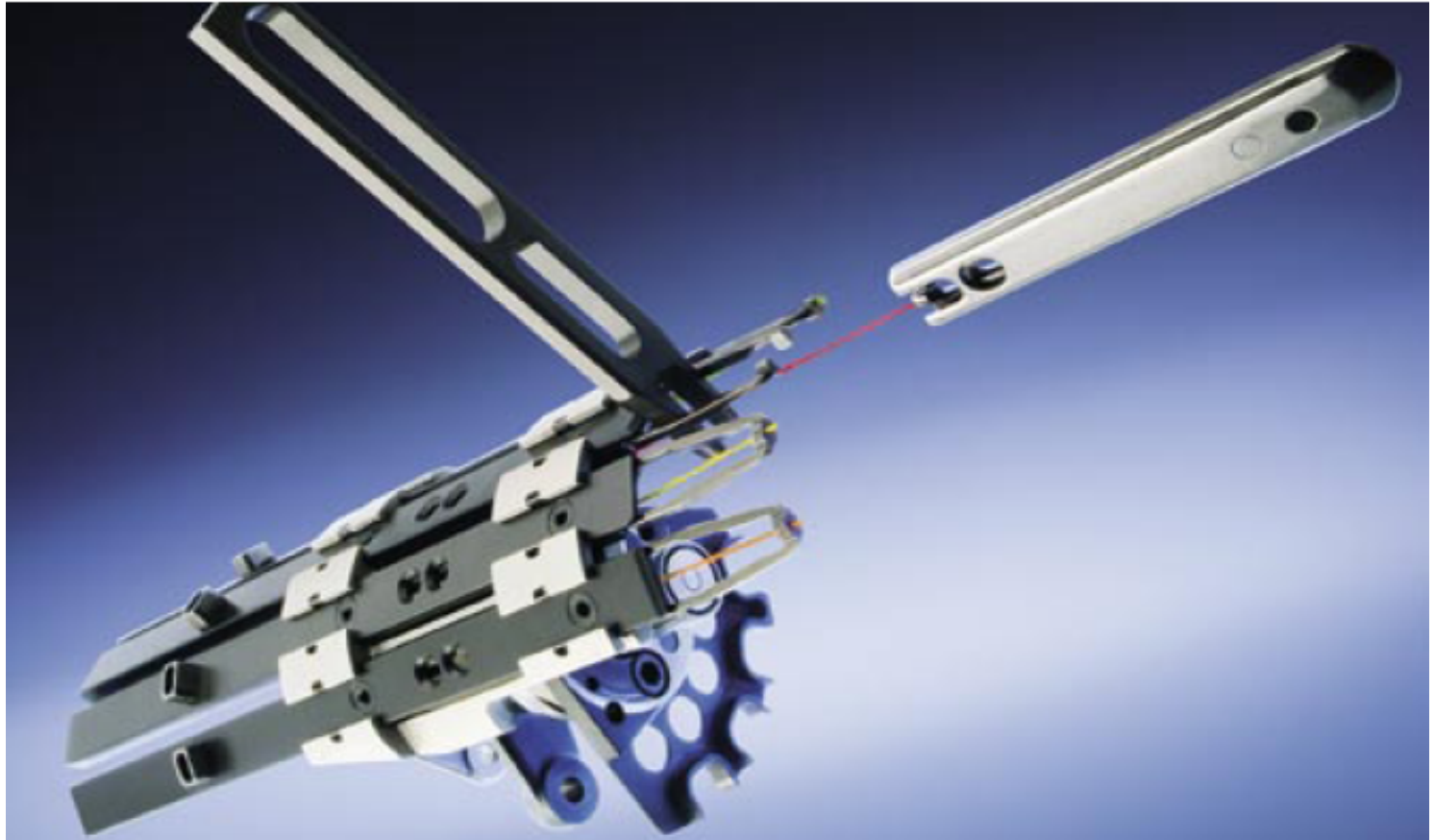

Projectile arriving

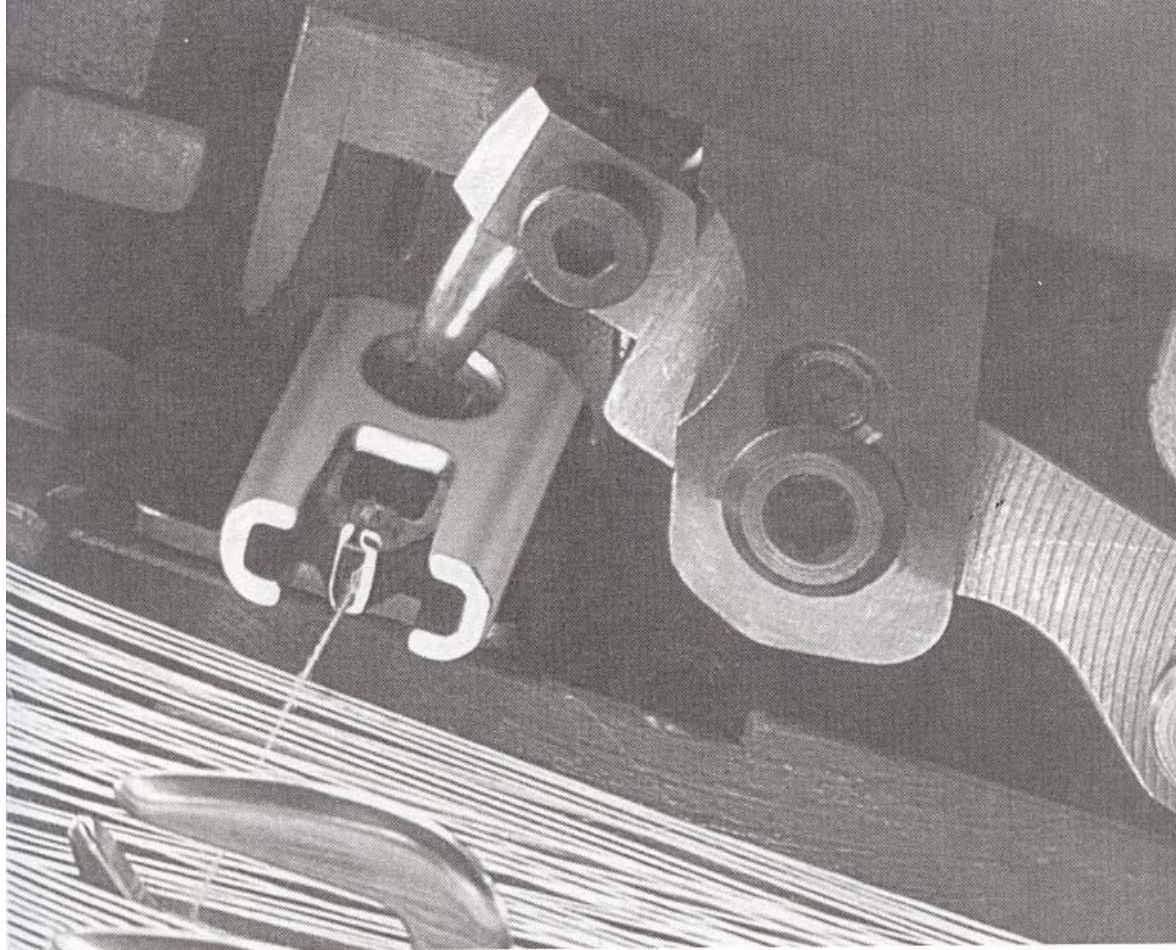

Checking

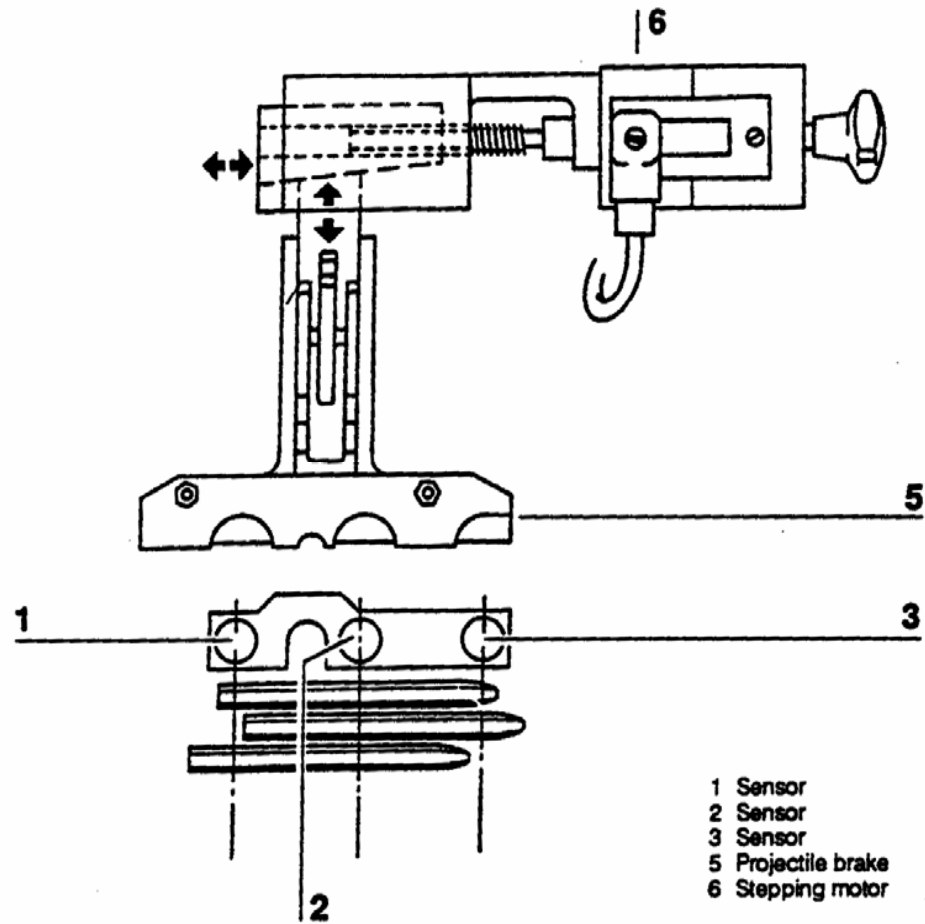

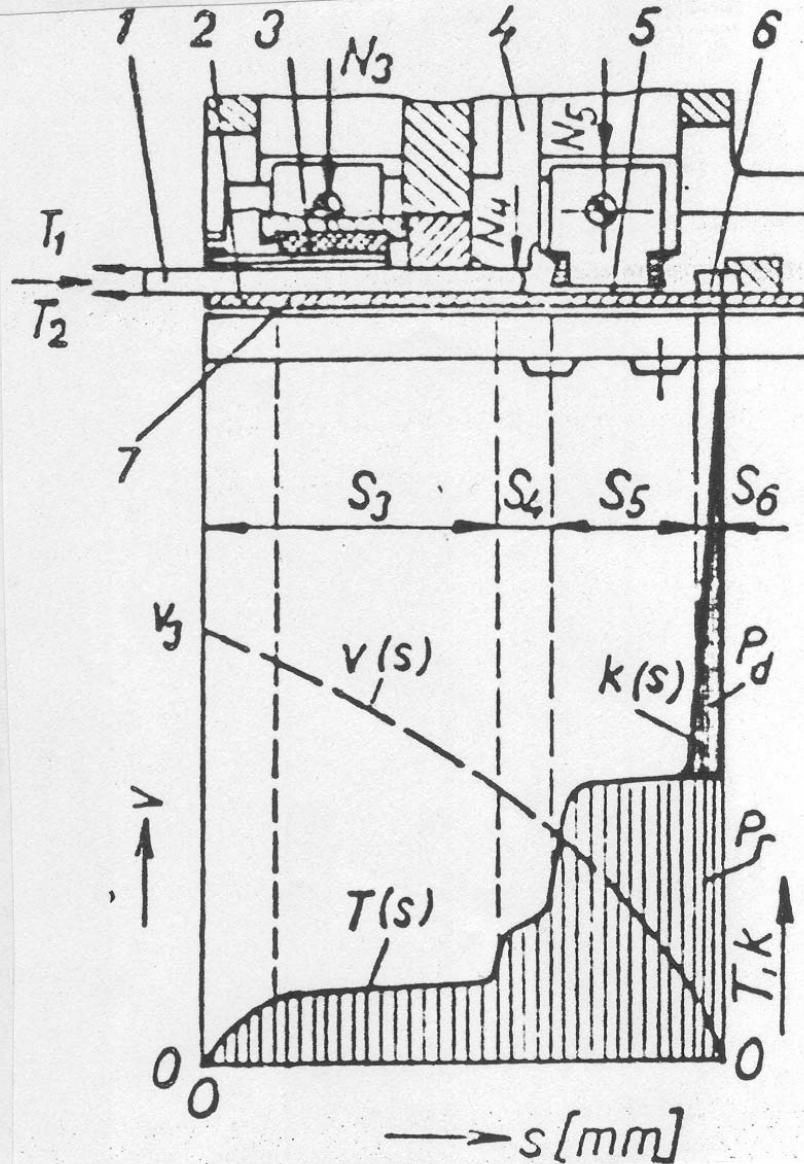
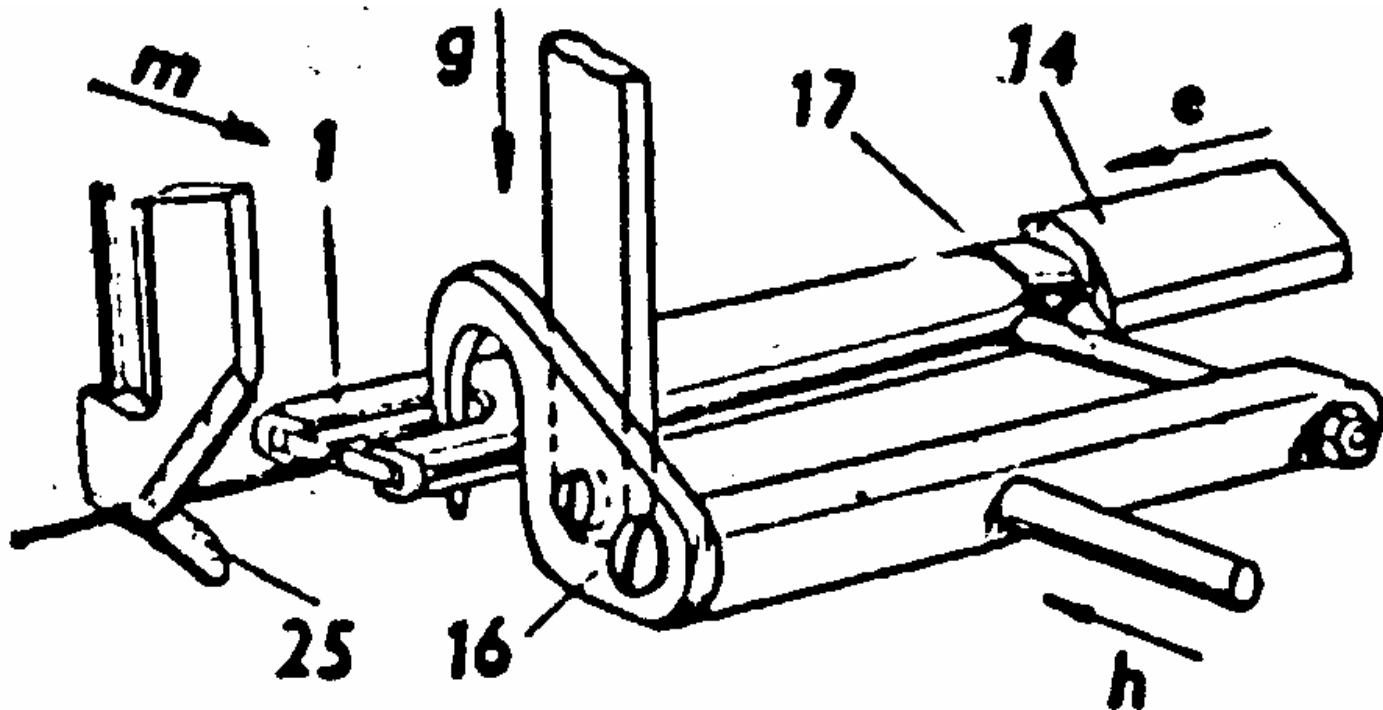
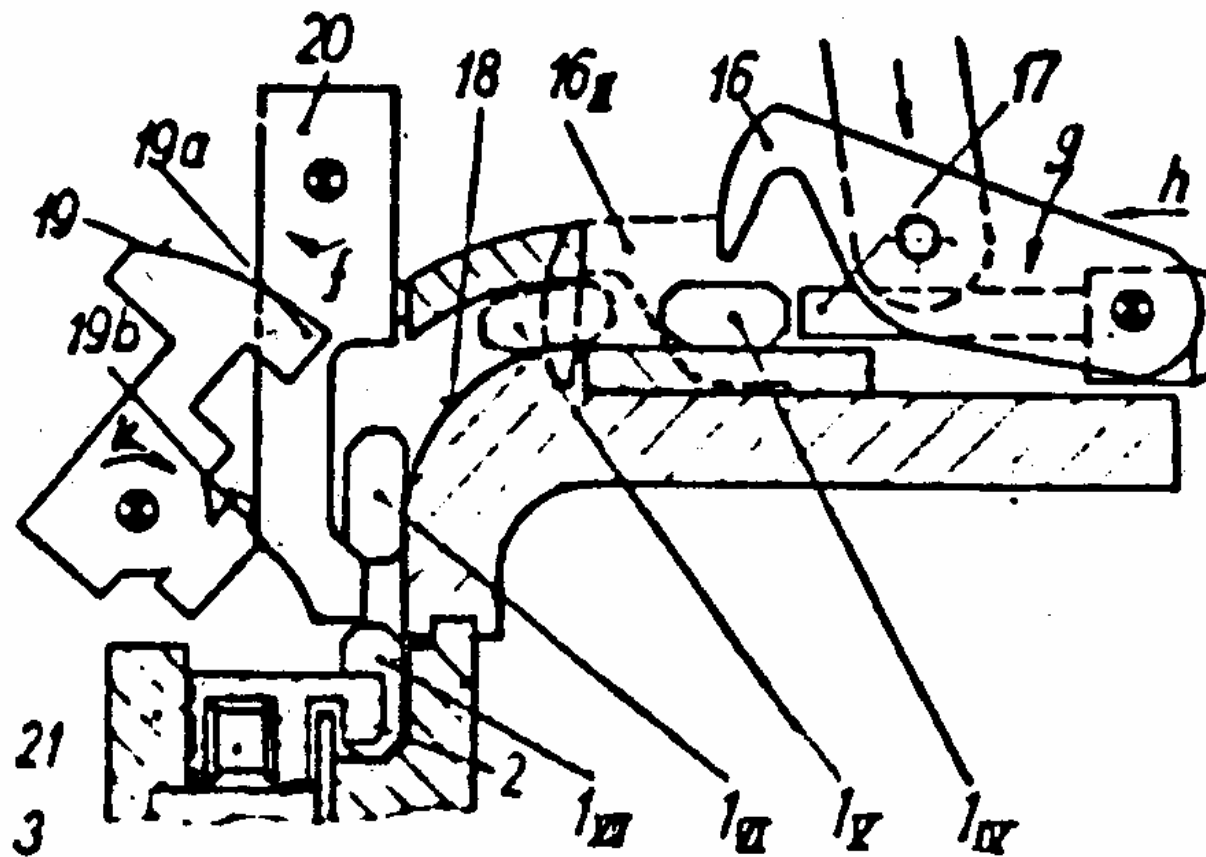

Fig. 6.4 The gripper projectile entry into the receiving box

Shifting after picking



Transfer on the conveyor



Projectile circulation

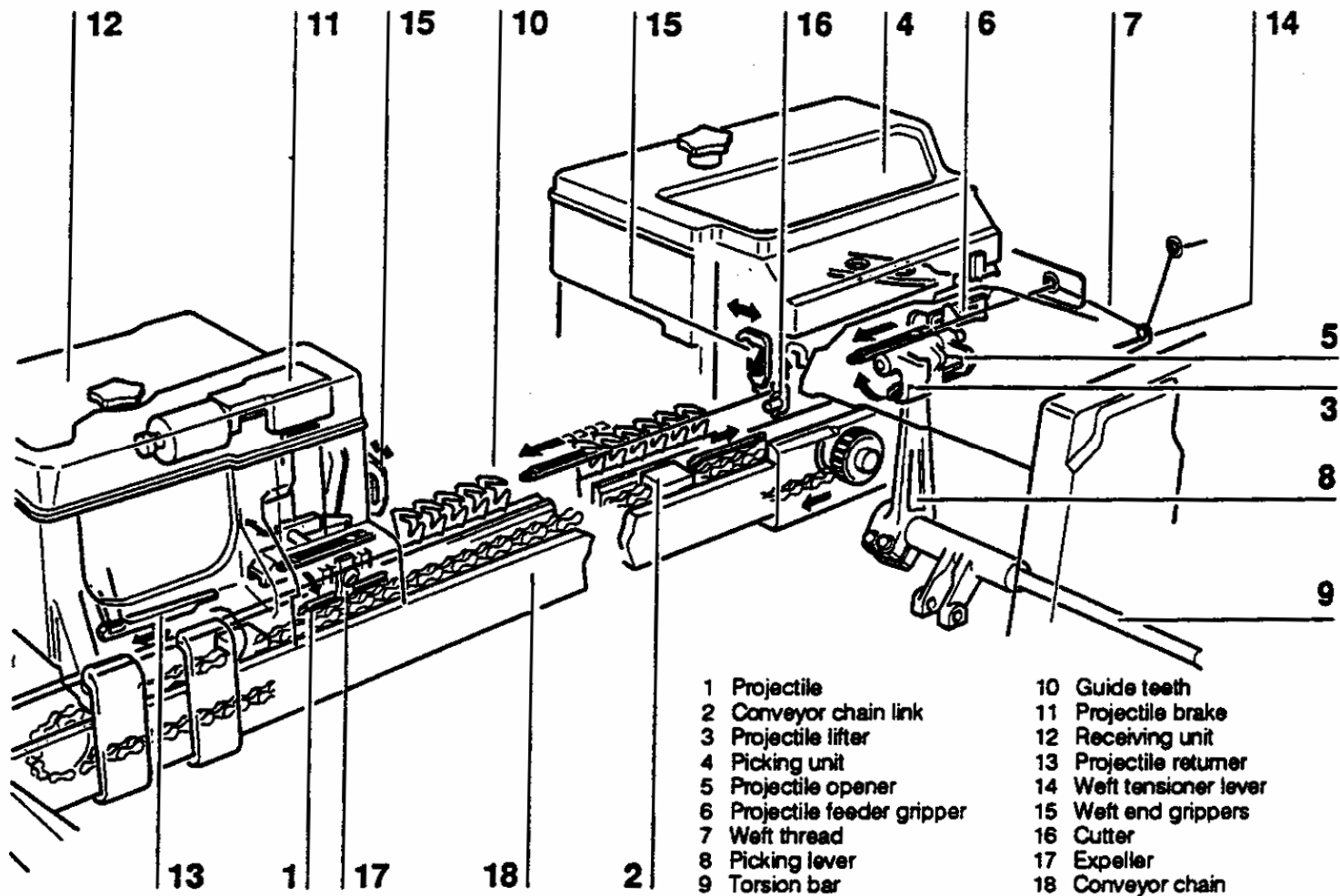

Yarn centering and cutting

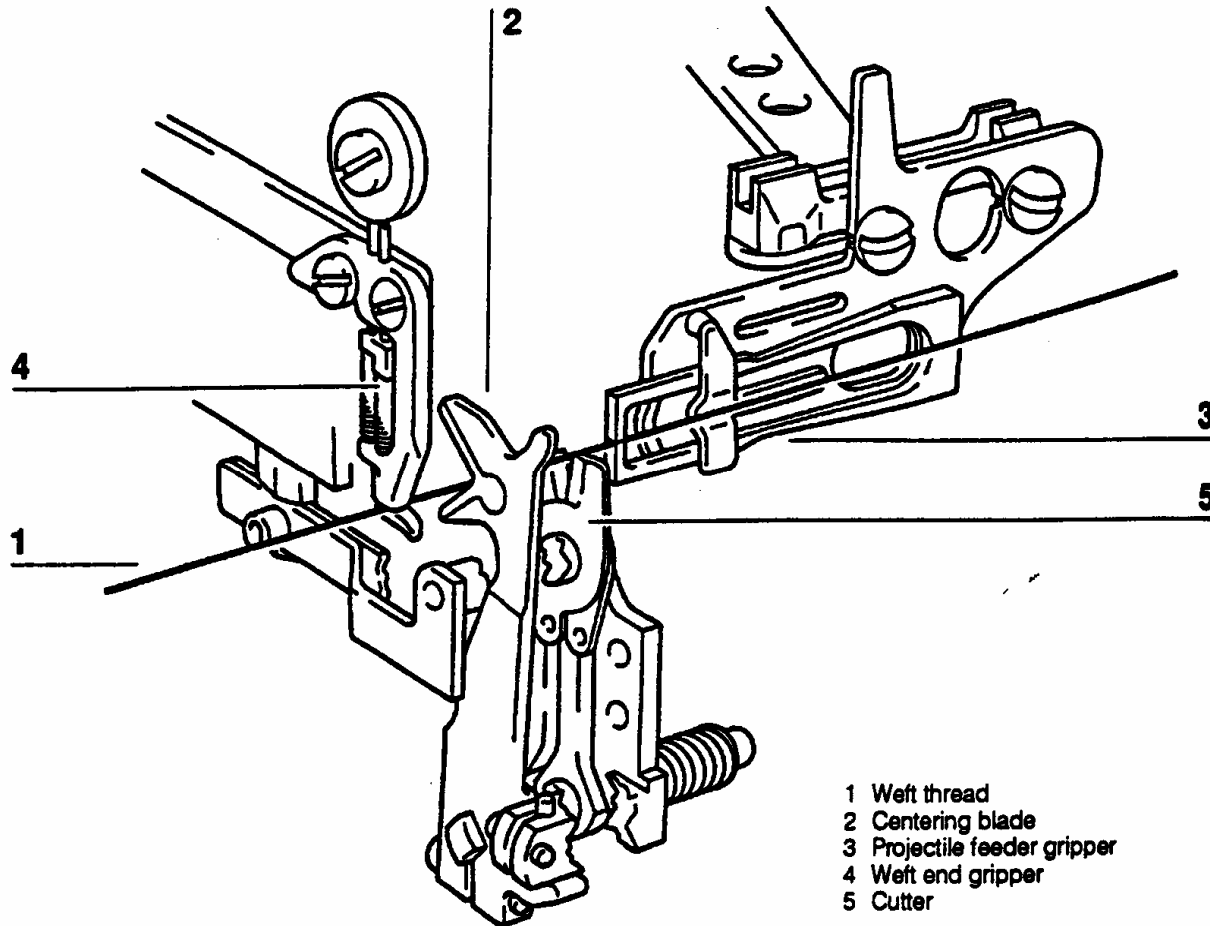

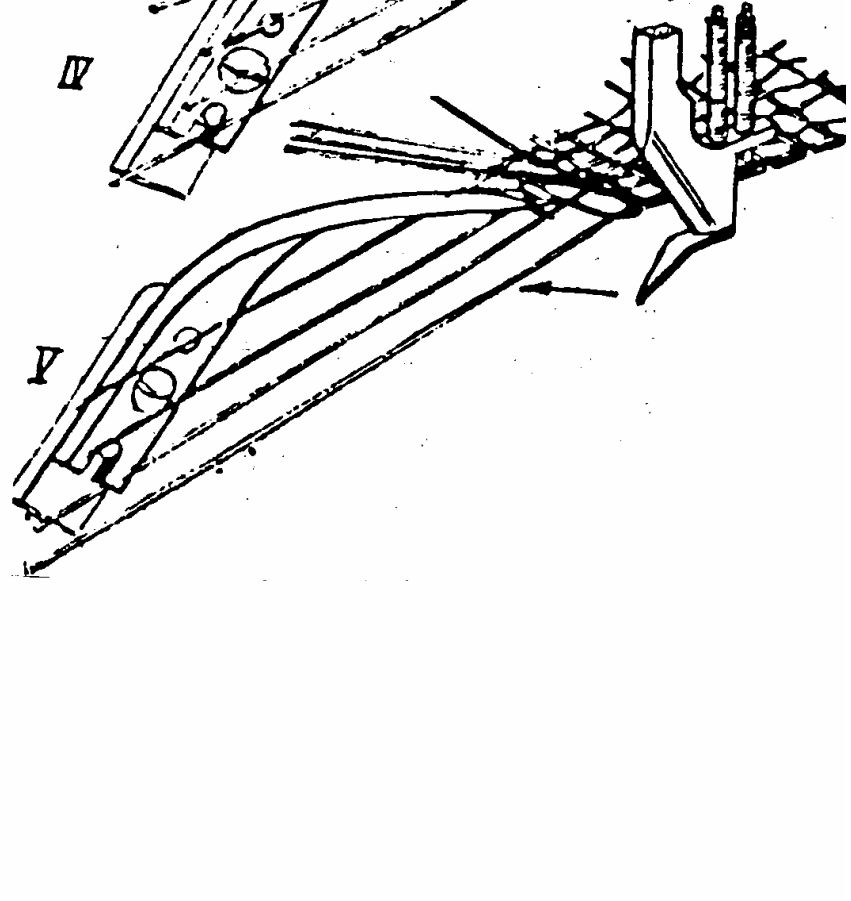
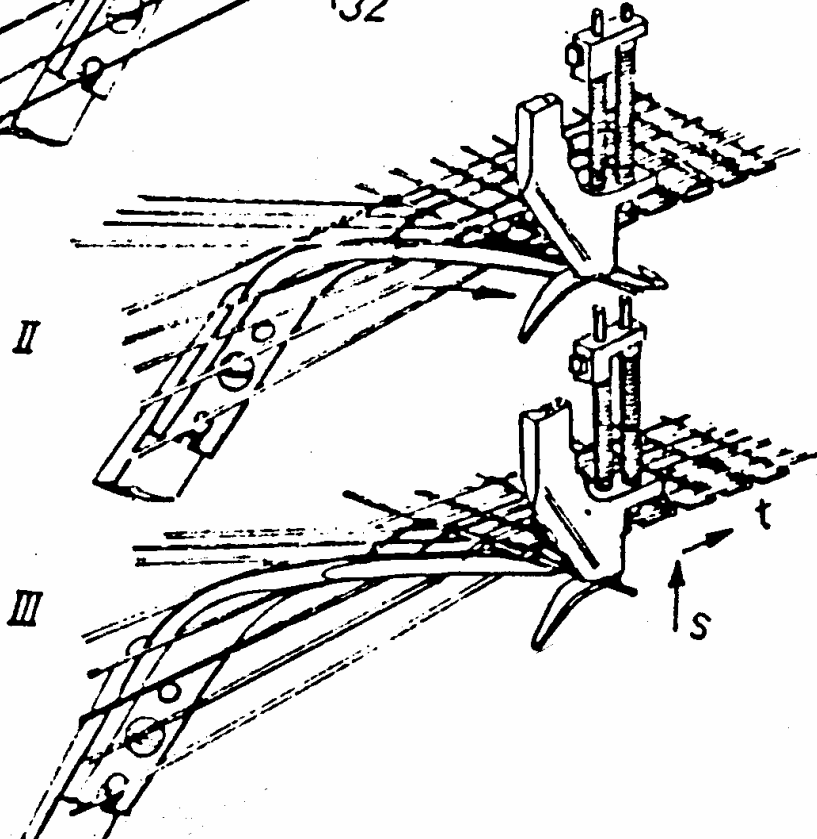
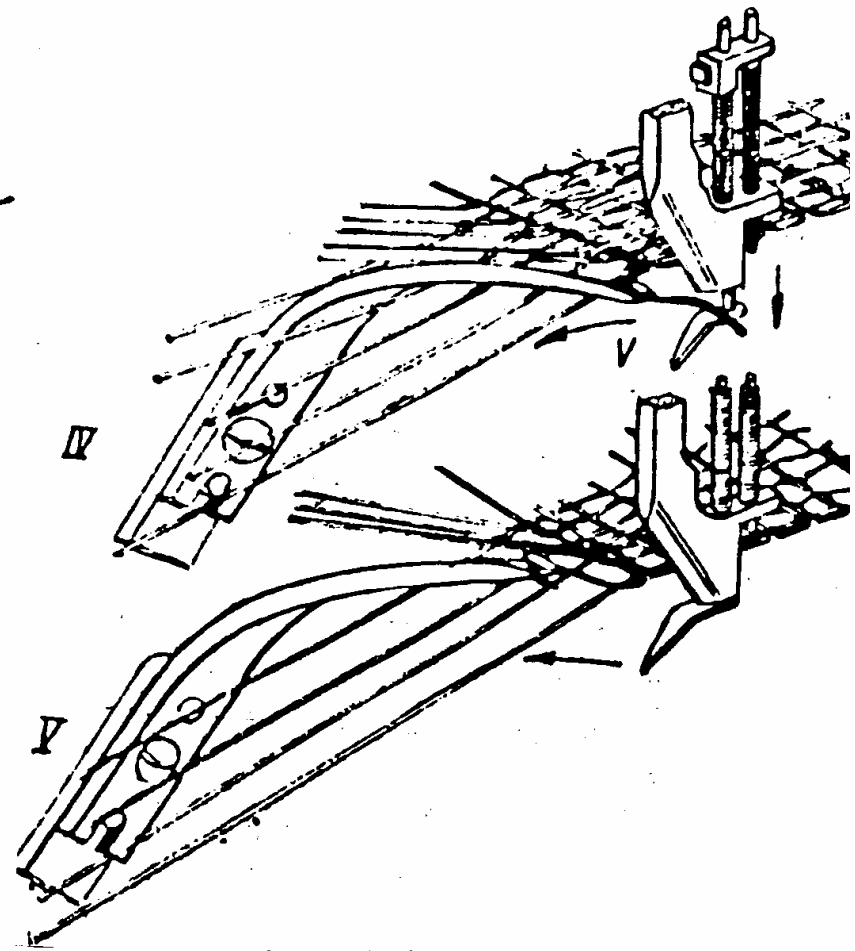
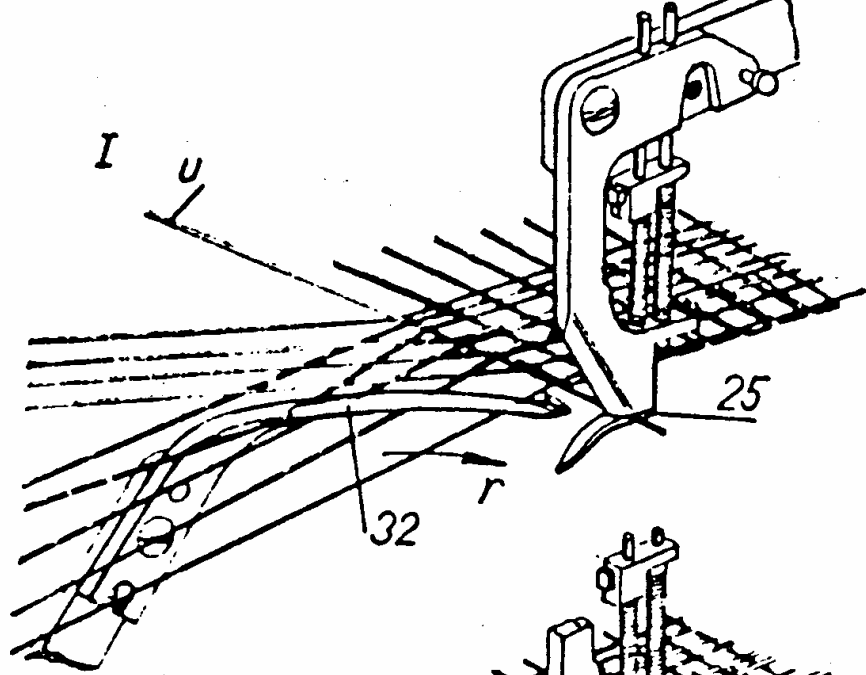

- The width of the tucked selvages can be set from 18 to 25 mm and even to 35 mm. Accurate weft length measurement ensures that there is no yarn wastage. Instead of tucking units, the P7300hp can be equipped with devices for producing leno or melted selvages. In the case of leno selvages the Selvedge Saver eliminates
- auxiliary selvages, thus economizing warp and weft yarn – a saving that translates into hard cash

Tucking-in

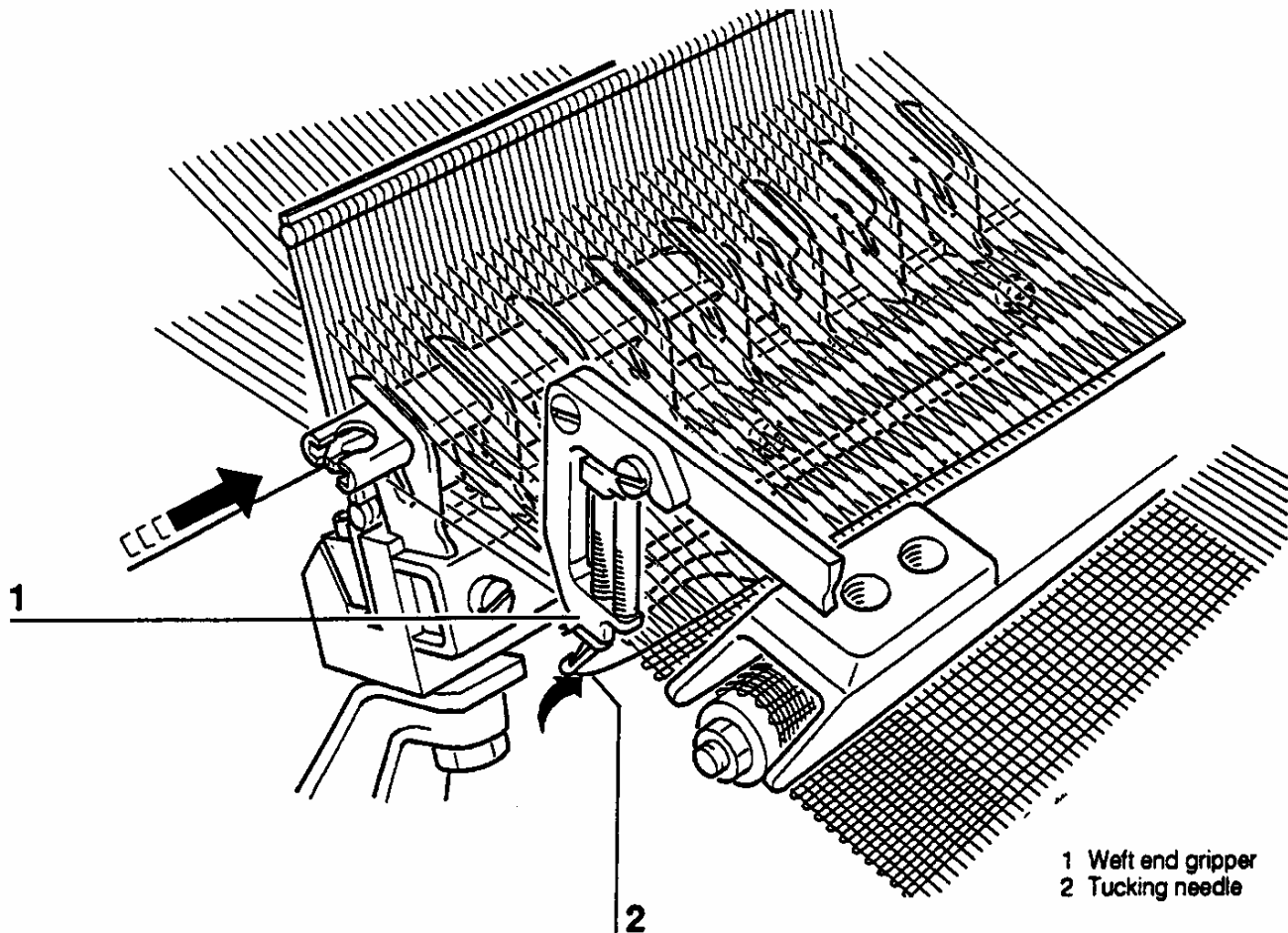

Sulzer Textil – design concepts for quality-conscious weavers

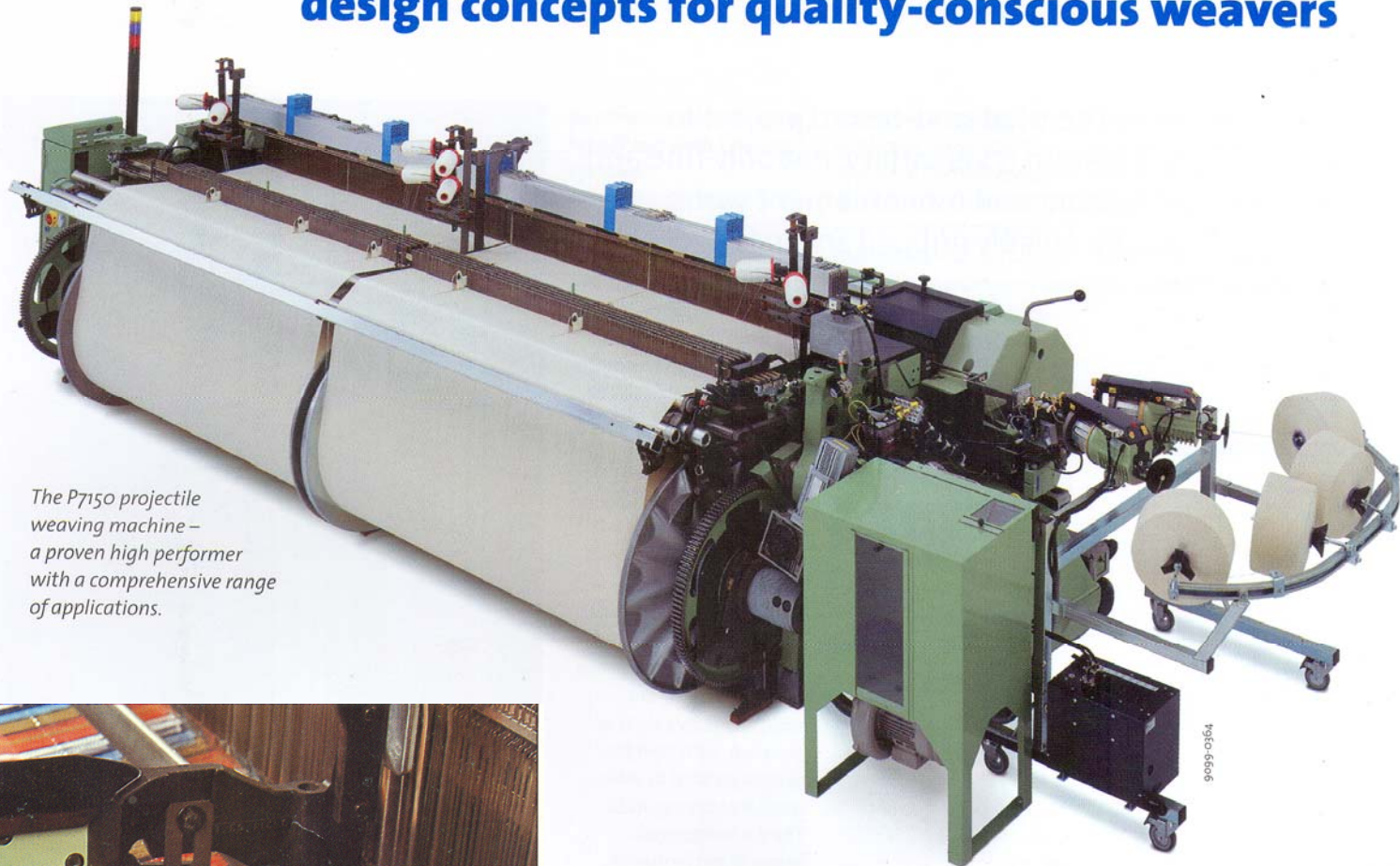

The P7150 projectile weaving machine – a proven high performer with a comprehensive range of applications.

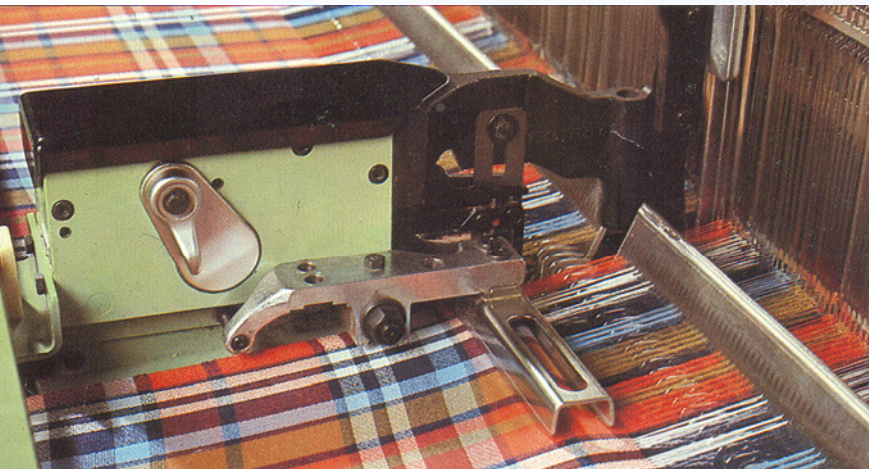

Sulzer terry weaving machine

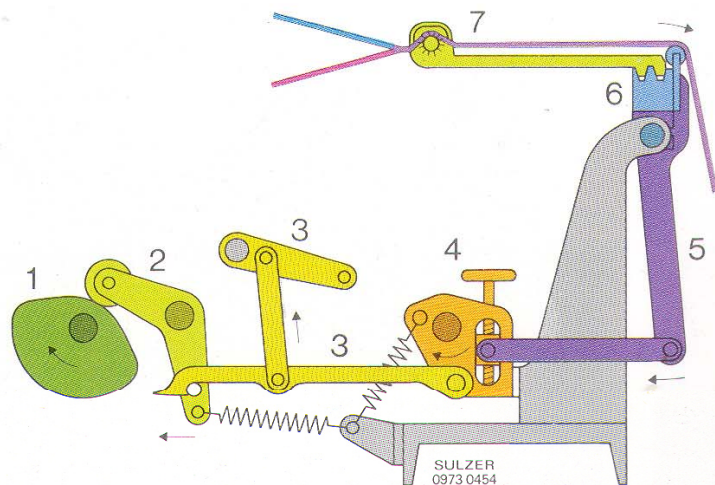

- 1 Terry motion cam
- 2 Roller lever
- 3 Draw hook
- 4 Lift adjusting lever
- 5 Draw link and drive lever
- 6 Movable breast beam
- 7 Slide with temple

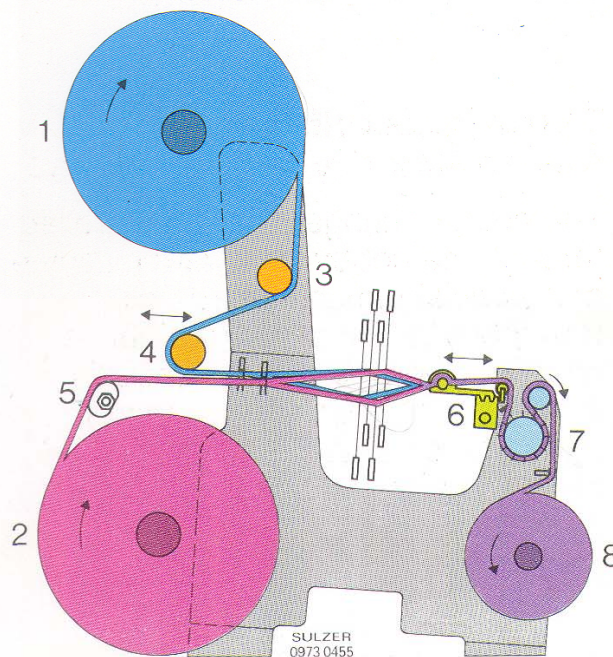

- 1 Ground warp
- 2 Pile warp
- 3 Deflection roller for ground warp
- 4 Whip roller for ground warp
- 5 Whip roller for pile warp
- 6 Movable breast beam and temple
- 7 Needle-type take-up beam
- 8 Cloth beam

Reduced tension on the weft yarn by air support

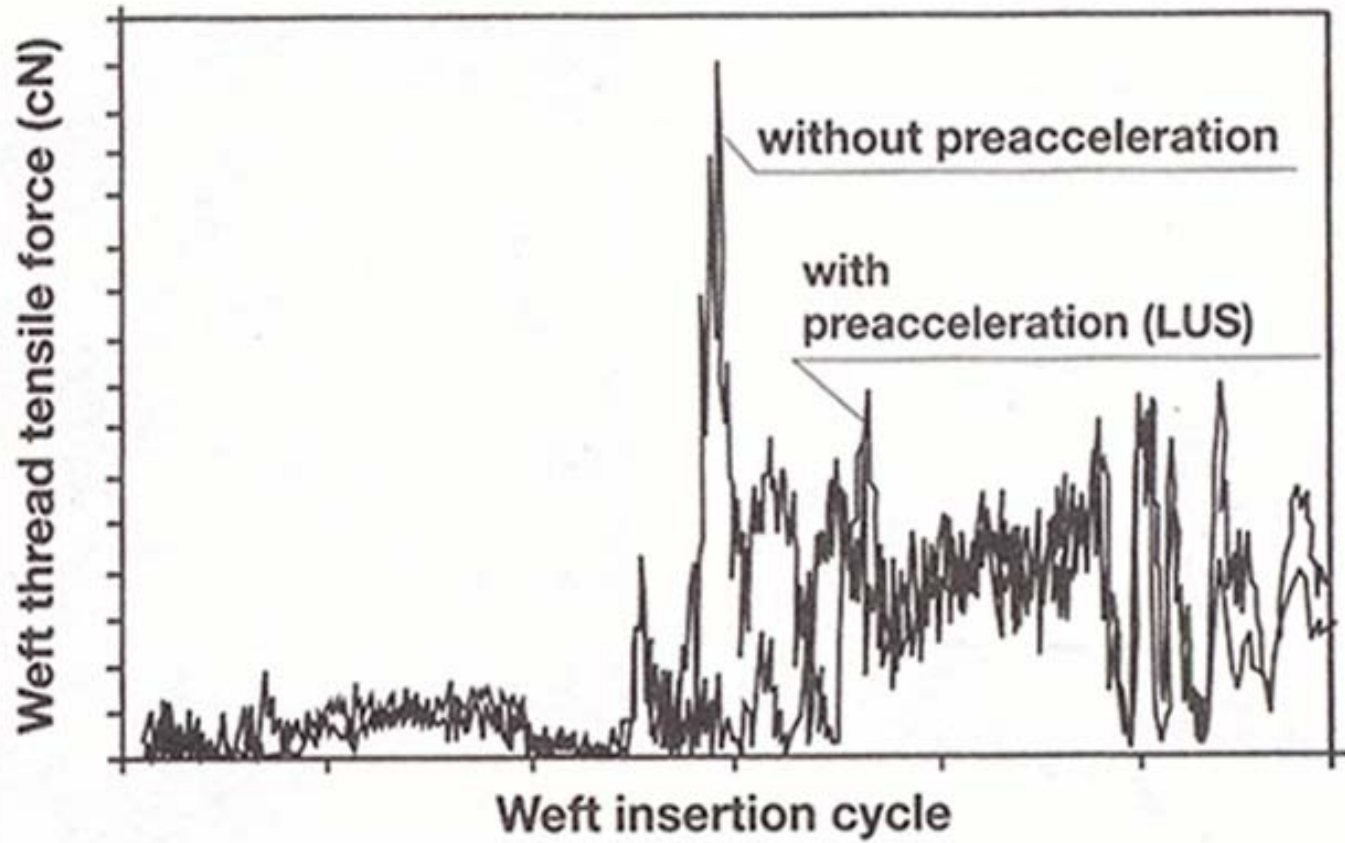

P7300HP

- The P7300HP is a high- performance, all-purpose projectile weaving machine.
- Optimized motion sequences and direct projectile acceleration with thrust shoe result in a maximum weft insertion rate of 1570 m/min.
- The P7300hp is available in nine working widths, from 190 cm to 540 cm. It is the only weaving machine for which 540 cm is a standard width. This has crucial advantages in the production of technical textiles.
- For instance, it enables agro- and geotextiles to be produced in large widths so that fewer eams are required.
- Curtains and drapes in large widths can be woven best and most easily on the P7300hp.





The production of fabrics from polypropylene tapes for geotextiles or agrotextiles,



P7300HP



- Projectile weaving machines have been used to produce countless technical textiles, from the finest filter fabrics to densely woven and tear-resistant special fabrics for balloons and even ultra-heavy coating fabrics.
- Denim fabrics are produced worldwide and with great success on projectile weaving machines.