

Yapı Statiđi

Öđr.Gör. Dr. Haluk Sesigür
İ.T.Ü. Mimarlık Fakültesi
Yapı ve Deprem Mühendisliđi Birimi



Figure 2.1
National Stadium, Beijing,
China, Herzog & De Meuron,
2008. An elevation of
the stadium.

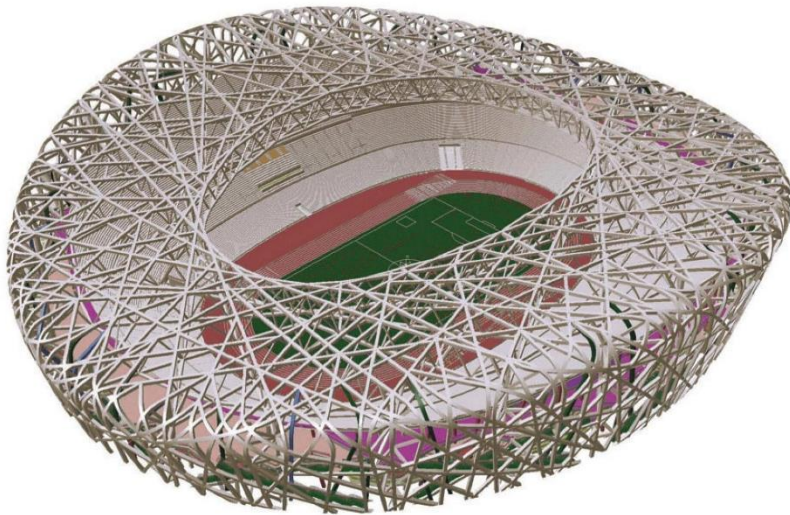


Figure 2.2
The perimeter steel structure
wraps around the inner
concrete bowl (Arup).

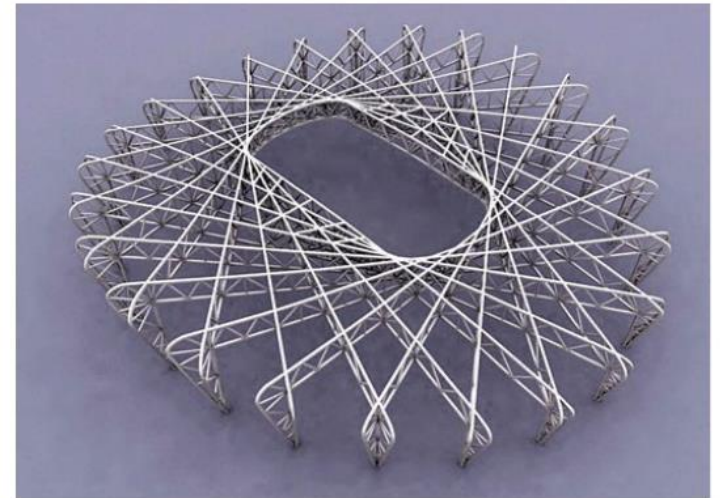


Figure 2.3
A physical model of the perimeter steel and roof gravity-resisting portal
frame structure (Arup).









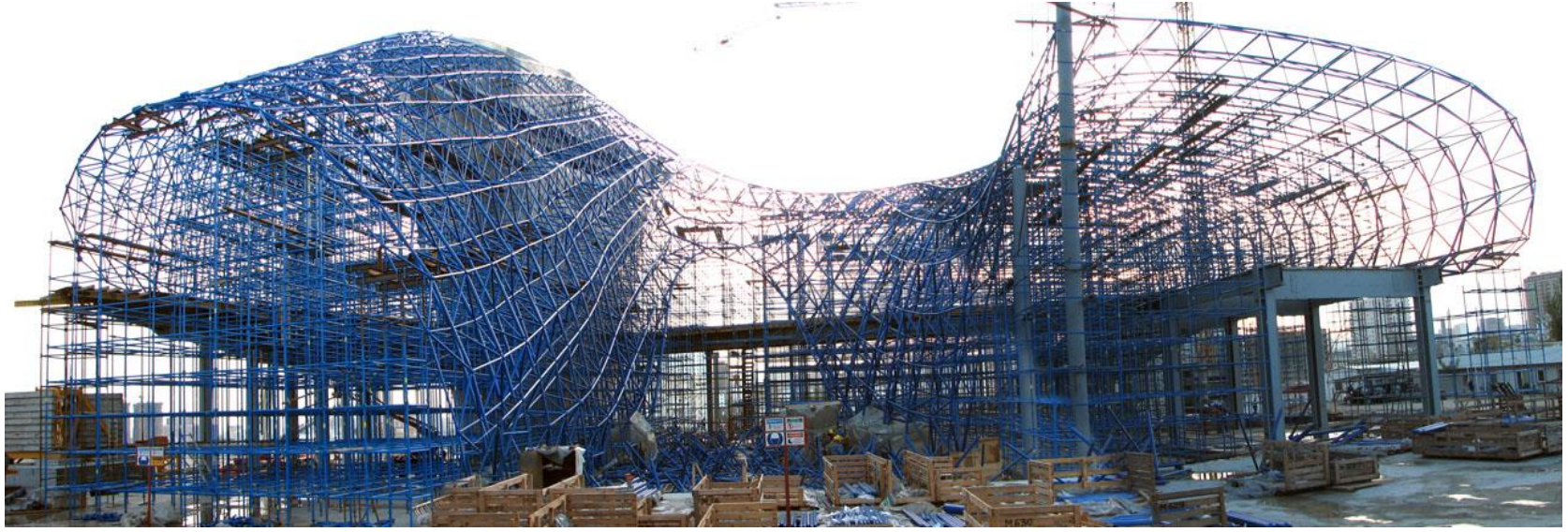








Figure 3.1
Library Square, Vancouver, Canada, Moshe Safdie and Associates Inc.,
1995. A typical longitudinal frame and the ends of perimeter transverse



Figure 3.3
Post and beam gravity structure. The beams, detailed as trusses, are
continuous over several spans.



Figure 3.2

Mont-Cenis Academy, Herne, Germany, Jourda & Perraudin, 1999. A glazed box with an entry canopy.

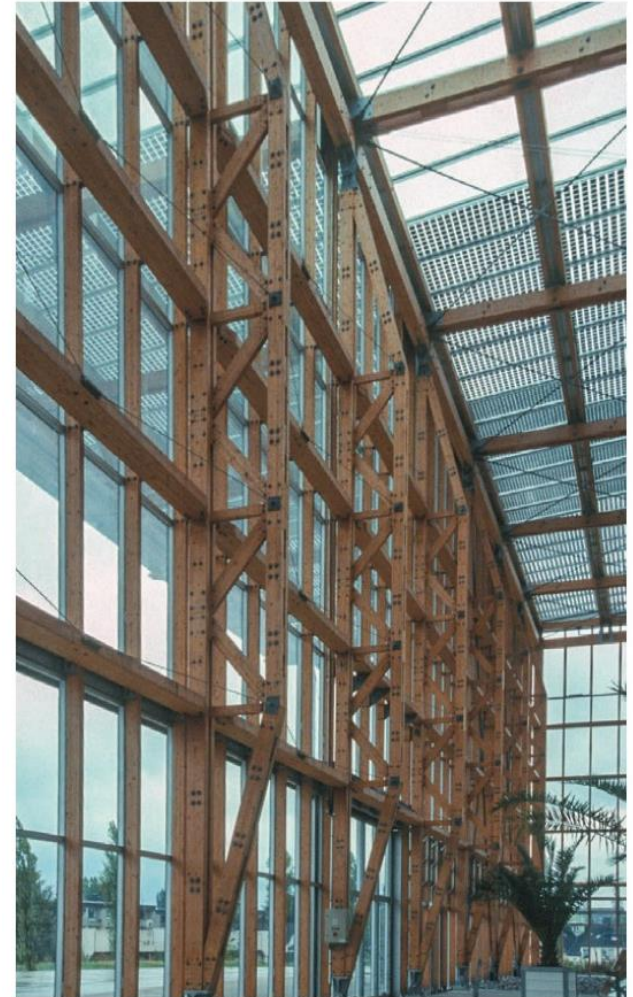


Figure 3.4

Vertical trusses support the wall. Steel tension-only bracing in the wall planes is not photographed but is similar to that of the roof diaphragm bracing which is visible.



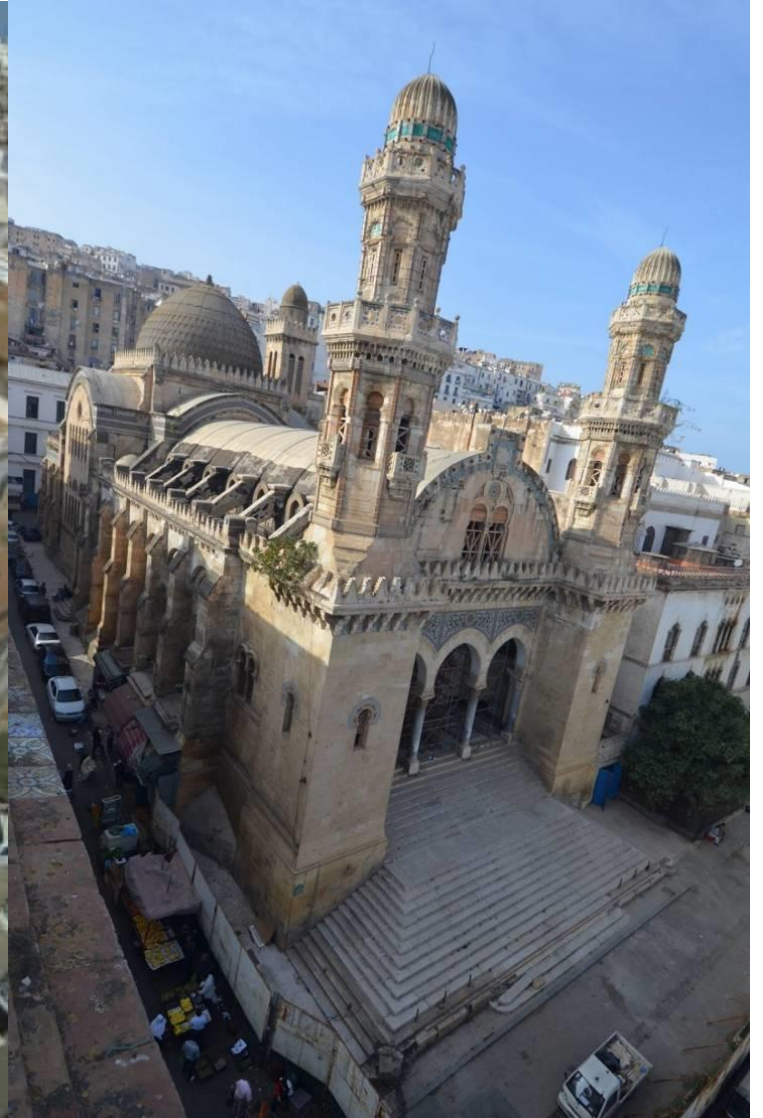
Figure 3.23

Tobias Grau headquarters,
Rellingen, Germany, BRT
Architekten, 1998. Glue-
laminated wooden ribs enclose
the ground-floor interior
concrete structure.

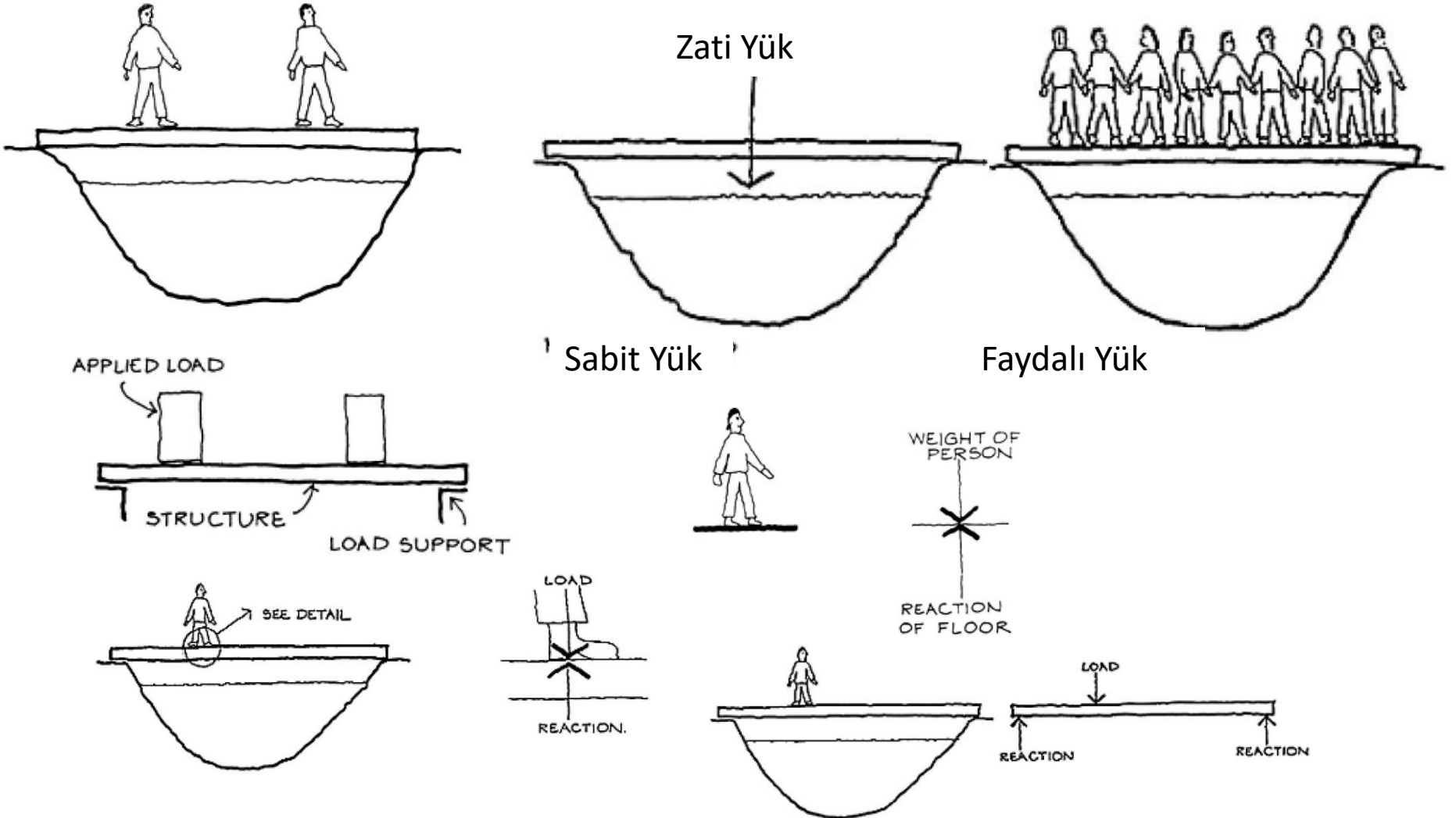


Figure 3.24

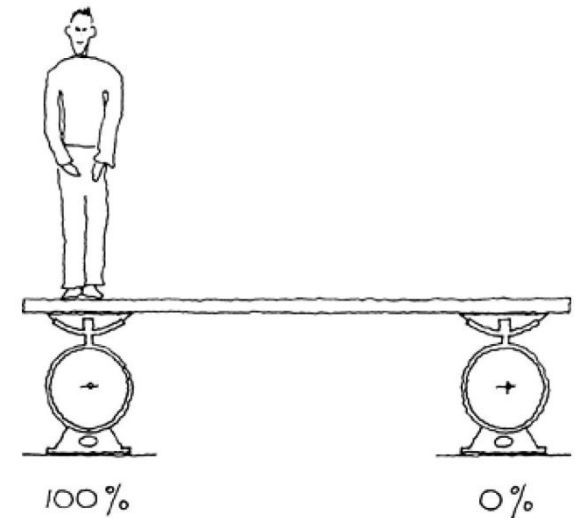
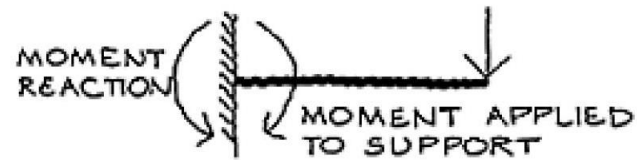
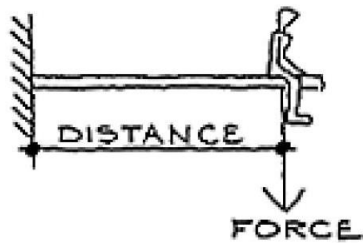
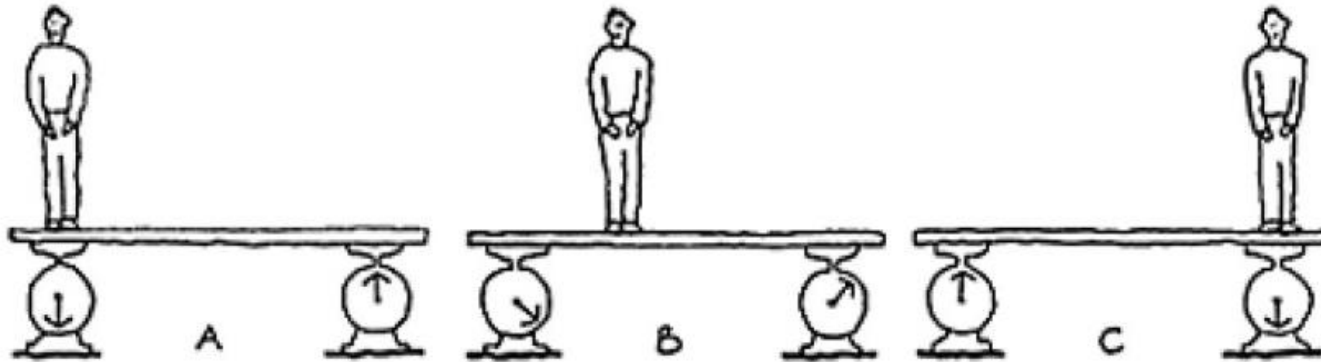
Curved wooden ribs behind glass louvers.



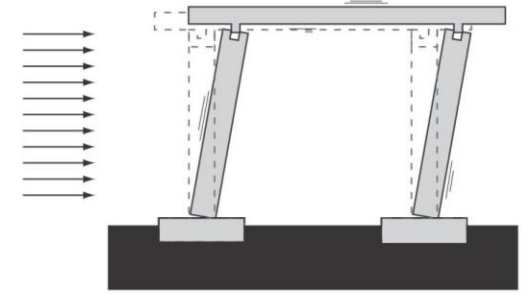
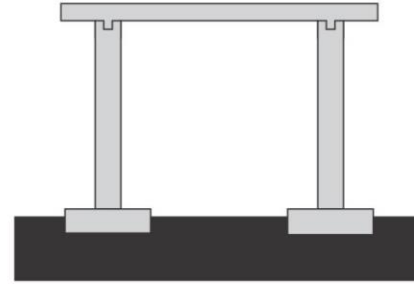
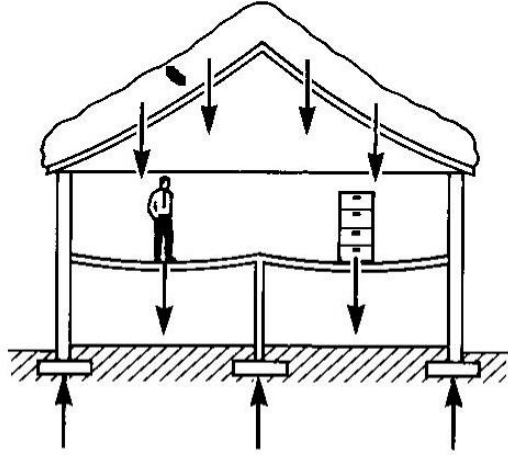
TAŞIYICI SİSTEMLER ve YÜKLER



DÜŞEY YÜKLER



YÜKLER ve MESNET TEPKİLERİ



Sabit mesnet

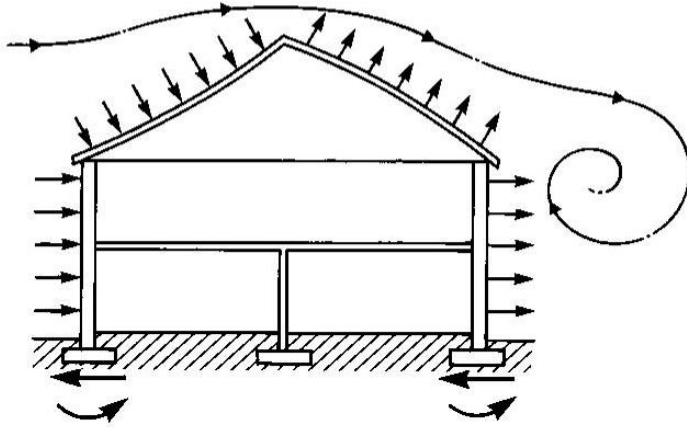
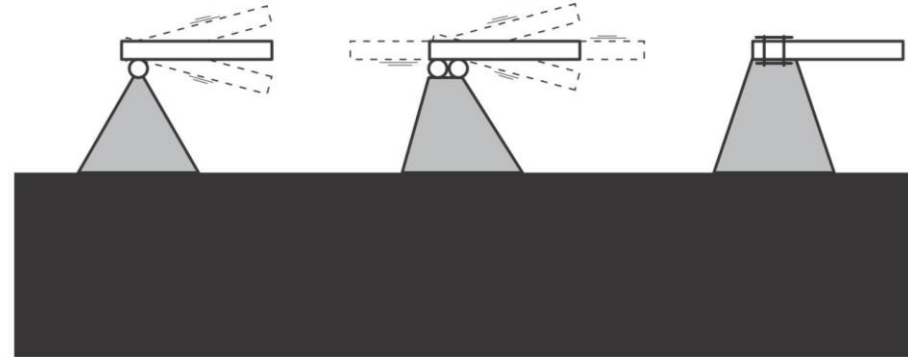
Hareketli mesnet

Ankastre mesnet

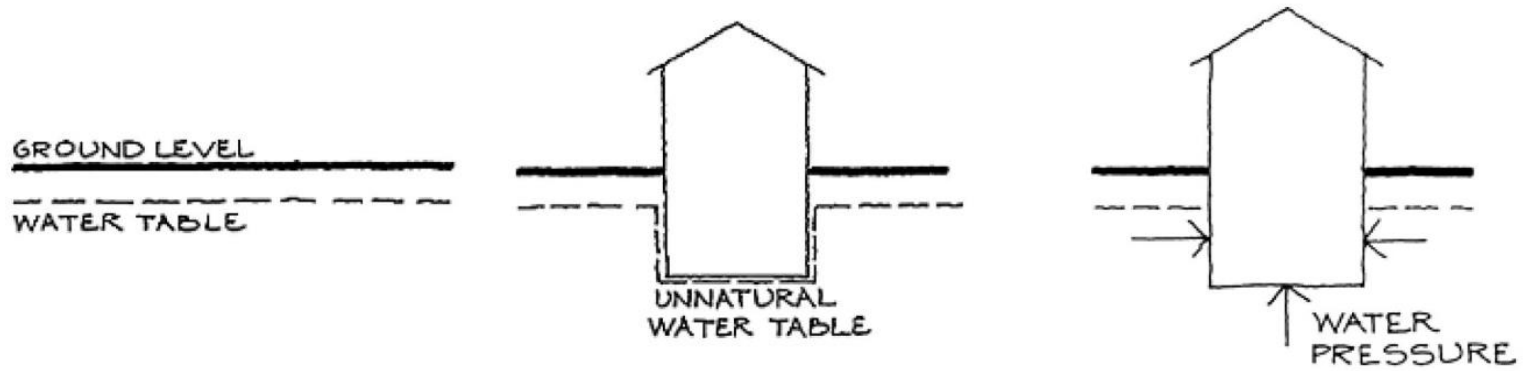
– allows rotation, not translation

– allows translation and rotation

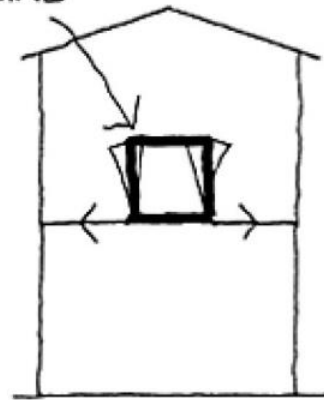
– allows translation and rotation



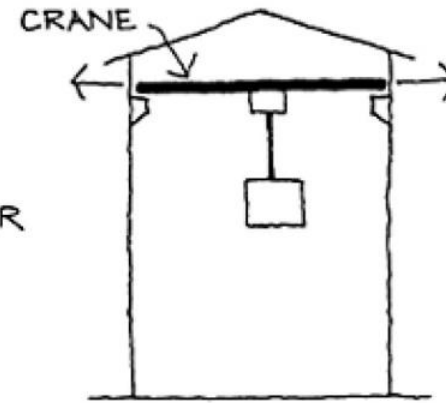
YÜKLER

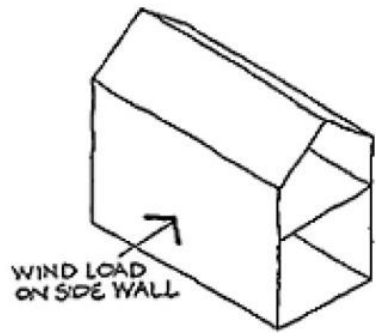
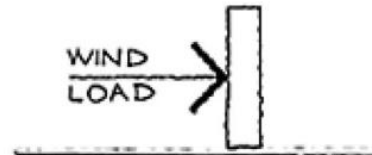
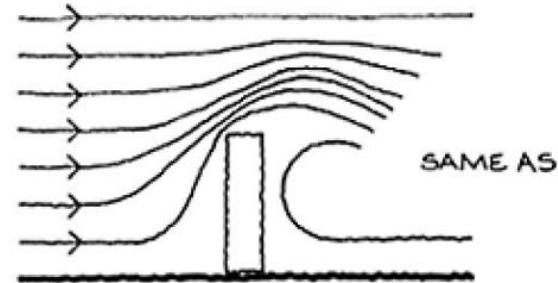
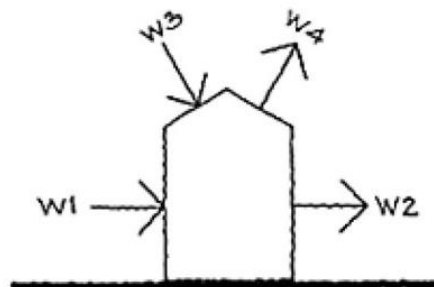
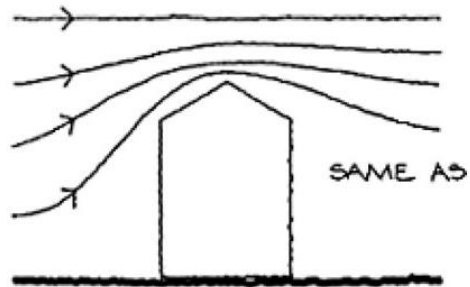


VIBRATING
MACHINE

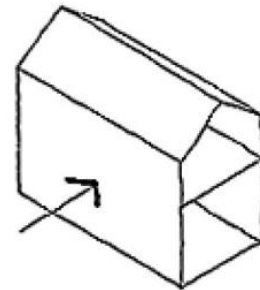
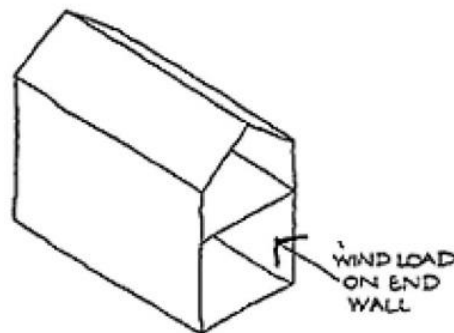


OR

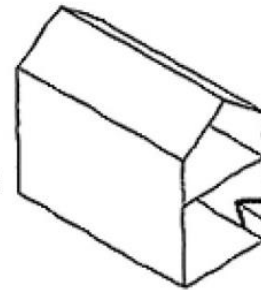




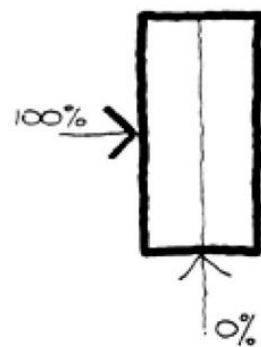
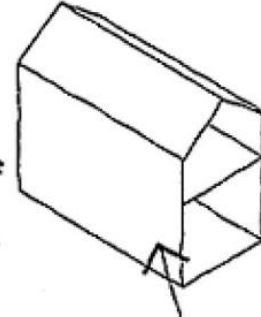
OR



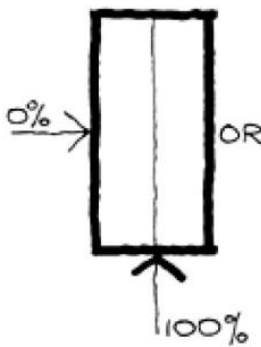
OR



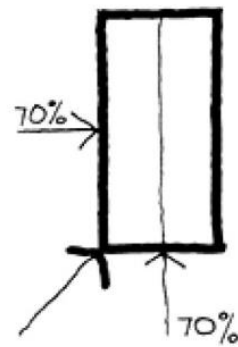
OR



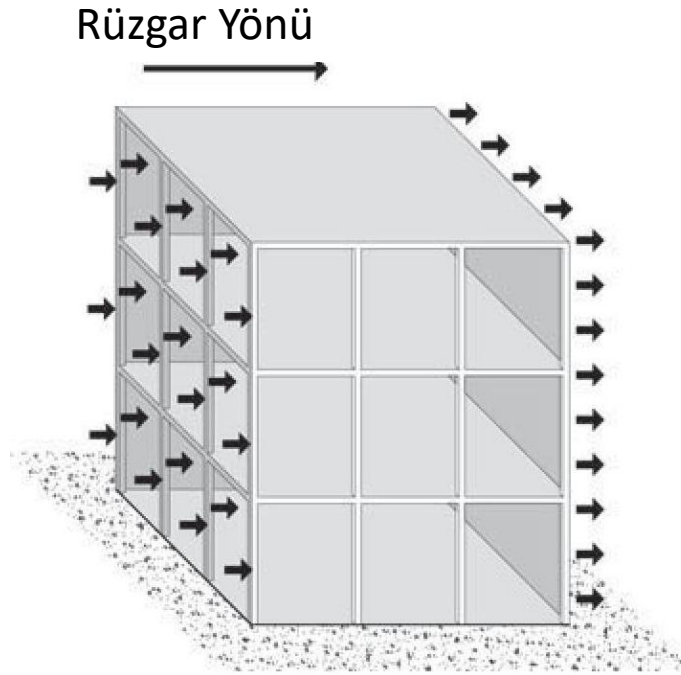
OR



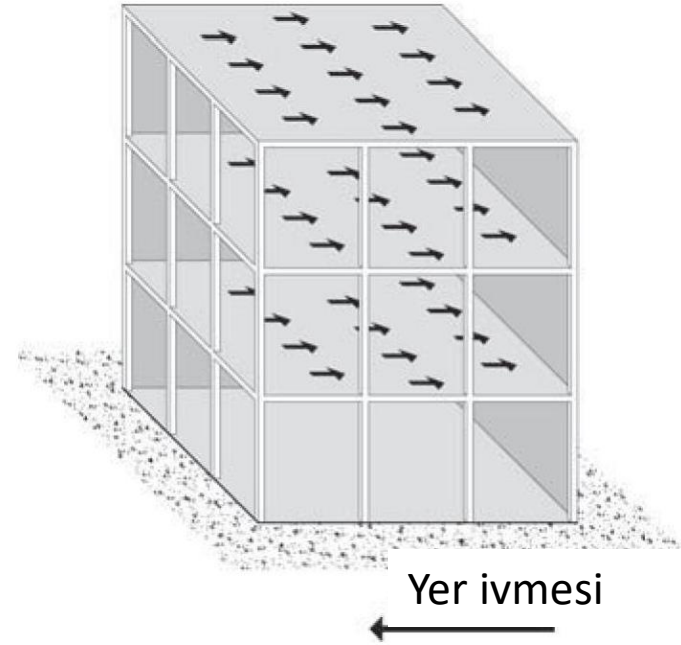
OR



YATAY YÜKLER

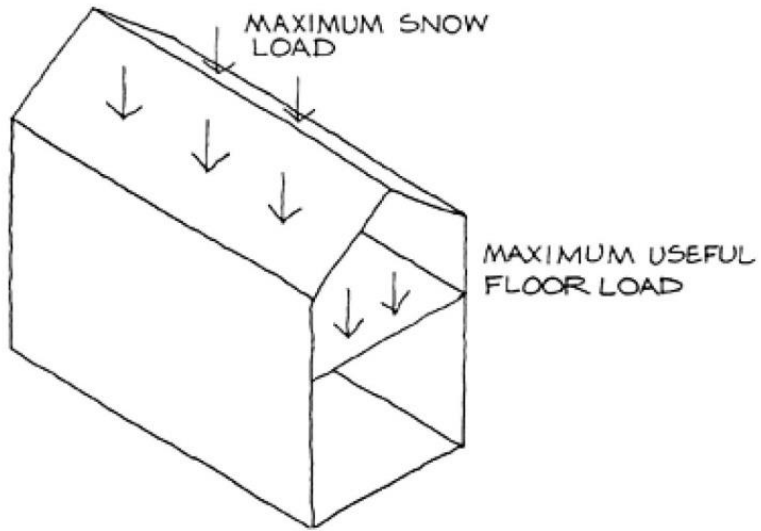


a) Yüzeye dik etkiyen rüzgar yükleri

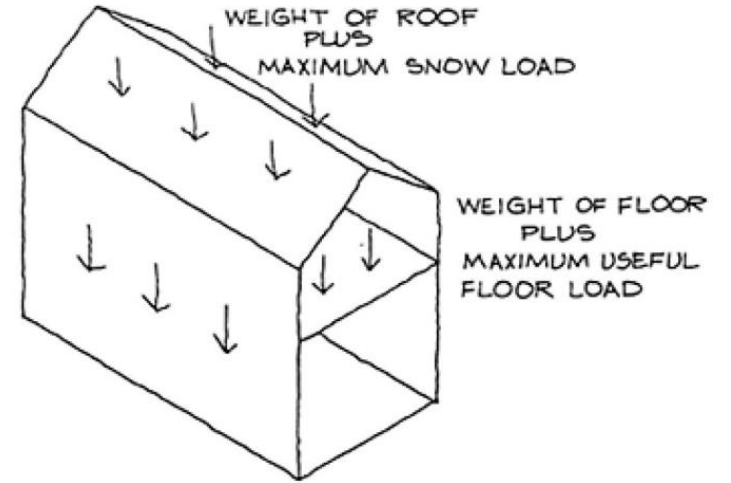


b) Depremden oluşan atalet kuvvetleri

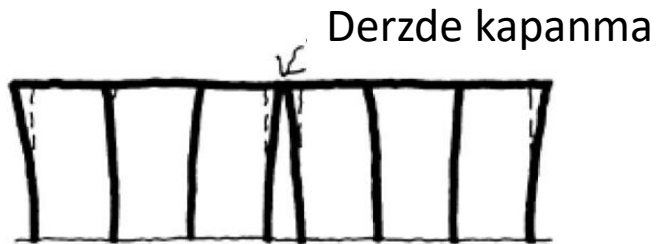
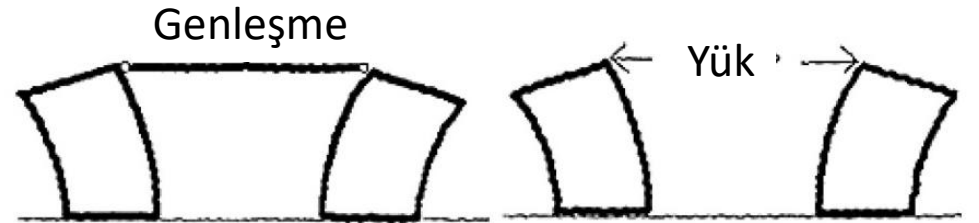
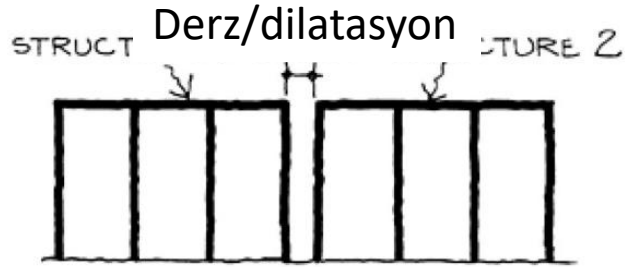
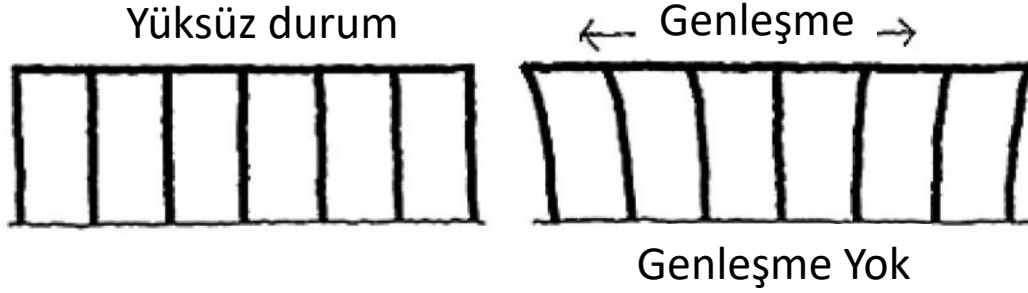
DÜŞEY YÜKLER



WEIGHT OF
WALLS

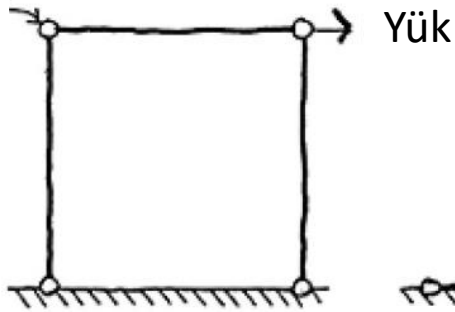


SICAKLIK DEĞİŞİMİ YÜKLERİ

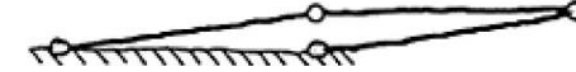


GÖÇME MEKANİZMASI

Mafsalsal

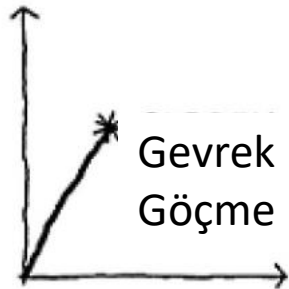


Mekanizma



Göçme Mekanizması

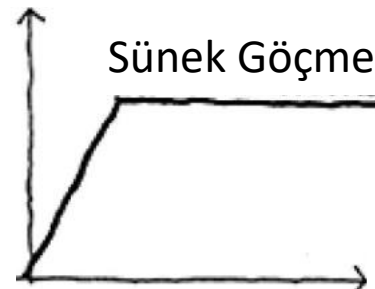
Yük



Gevrek
Göçme

Yer-
değiştirme

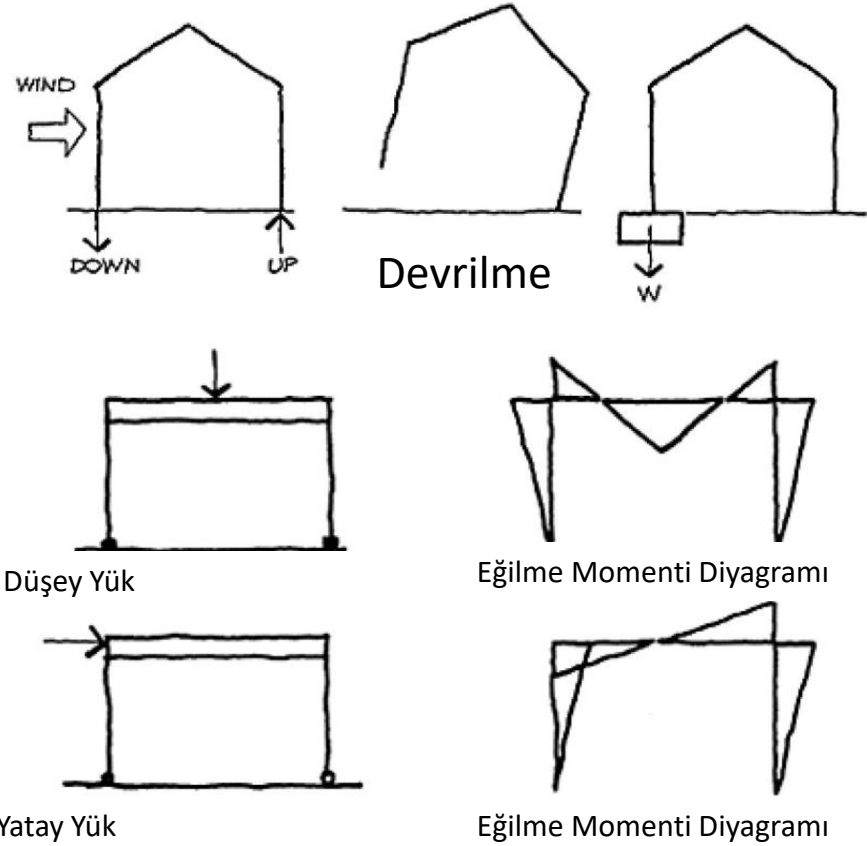
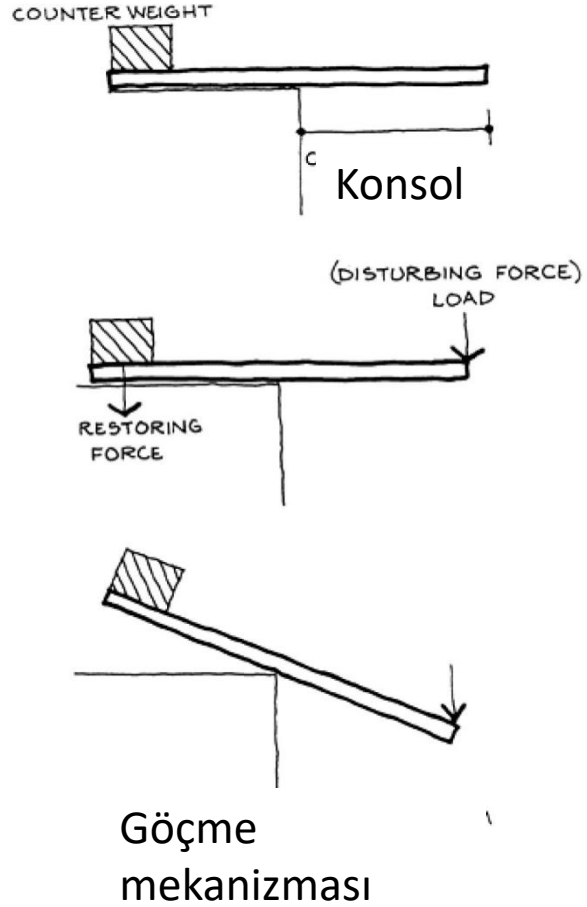
Yük



Sünek Göçme

Yer-
değiştirme

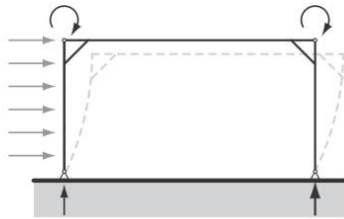
TAŞIYICI SİSTEMLER



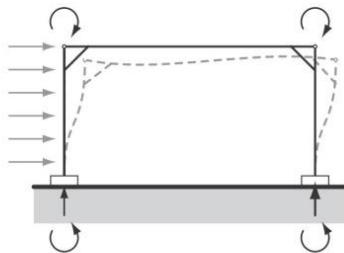
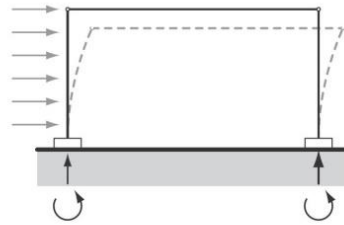
ÇERÇEVE SİSTEMLERİ



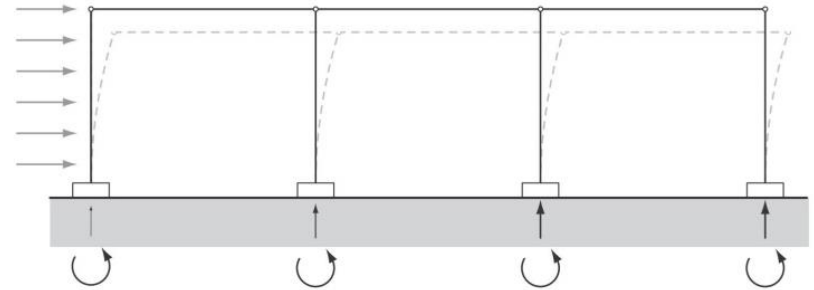
Unbraced (hinged) frame



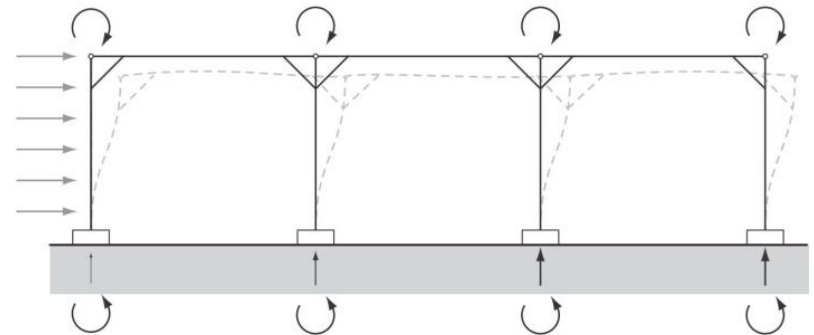
Single braced frames



Doubly braced frame (indeterminate)

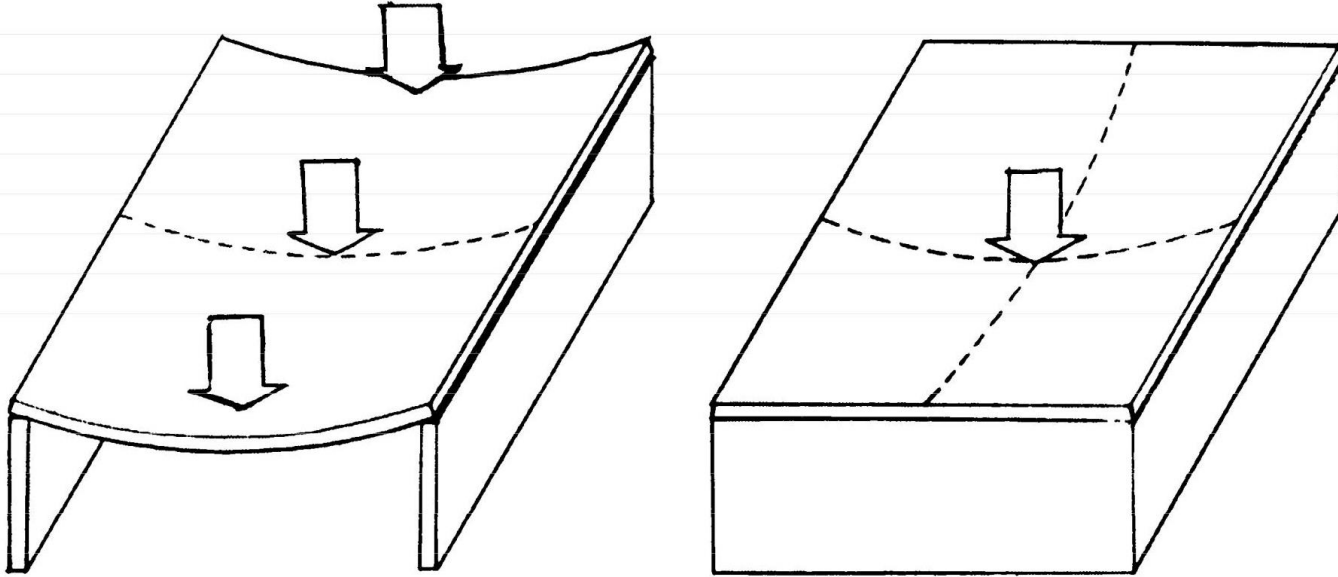


Multiple frame (braced at foundation only)



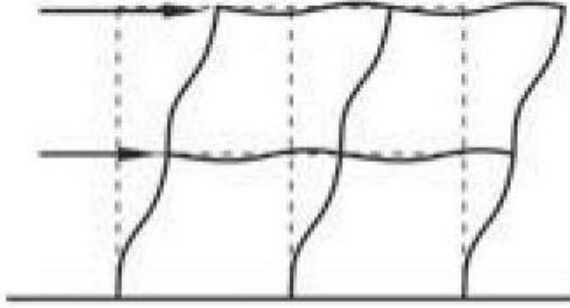
Multiple frame (braced throughout)

YÜZEYSEL TAŞIYICI ELEMANLAR



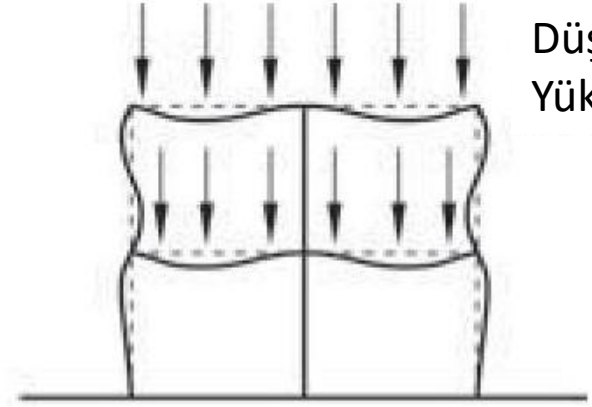
DEFORMASYON DURUMU

Yatay
Yük



(a)

Düşey
Yük



(b)

HAREKETLİ MESNET



İ.T.Ü. Mimarlık Fakültesi
Yapı ve Deprem Mühendisliği Birimi

Öğr. Gör. Dr. Haluk Sesigür

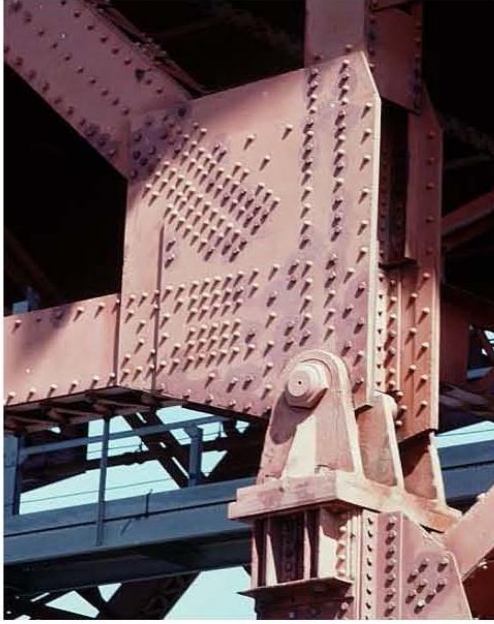
HAREKETLİ MESNET



İ
Yapı Statiği ve Betonarme Birimi

Oğr. Gör. Dr. Haluk Sesigür

SABİT MESNET



İ.T.Ü. Mimarlık Fakültesi
Yapı Statiği ve Betonarme Birimi

Öğr. Gör. Dr. Haluk Sesigür



▲ **7.29** Stratford Regional Station, London, England, Wilkinson Eyre, 1999. Curved frames spring from cast-steel bases.



▲ **7.30** Lyons School of Architecture, France, Jourda et Perraudin, 1988. A cast-steel shoe expresses the compression load-path.



▲ **7.31** A beam-column connection where a horizontal gap between the castings allows for a down-pipe to pass through the detail where required.



▲ **7.32** Palau Güell, Barcelona, Spain, Antonio Gaudí, 1880. Cantilevering brackets clasp the oriel floor.



▲ **6.16** Portland Building, University of Portsmouth, England, Hampshire County Council Architects Department, 1996. The timber framework creates spatial zones within a studio.



▲ **6.17** Lyons School of Architecture, Lyons, France, Jourda et Perraudin, 1988. Structure breaks up a large studio area.

4.33 Lattice girders combine with fabricated steel columns making a hybrid-portal structure at the Brit School, Croydon (architect: Cassidy Taggart)

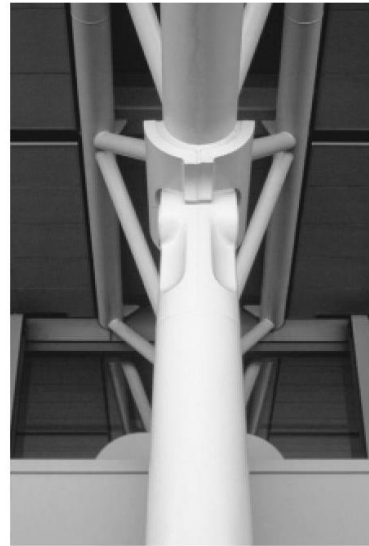




6.13 Typical pinned connection to a foundation



6.14 Pinned connections at Ponds Forge Swimming Pool, Sheffield — see also Colour Plate 20 (architect: FaulknerBrowns)



13.8 Fire clad columns, Kansai Airport (architect: Renzo Piano)



1.3 Pavilion at the Millennium Dome, Greenwich, UK (architect: Richard Rogers Partnership)



1.4 Thames Valley University, pin-jointed connections supporting curved-arched steel members (architect: Richard Rogers Partnership)



1.6 St Paul's Girls School (architect: FaulknerBrowns)



1.7 Inland Revenue Headquarters, Nottingham, showing truss details which provide interest and articulation (architect: Michael Hopkins and Partners)



1.8 Operations Centre at Waterloo, London, showing a fabricated cantilever beam supporting a walkway (architect: Nicholas Grimshaw & Partners)

