

Mukavemet

İç Kuvvet Diyagramları



Dr. Haluk Sesigür
İ.T.Ü. Mimarlık Fakültesi
Yapı ve Deprem Mühendisliği

KİRİŞ MESNETLENME TİPLERİ VE YÜKLER

The design of a beam entails the determination of size, shape, and material based on the bending stress, shear stress, and deflection due to the applied loads (Figure 7.1).

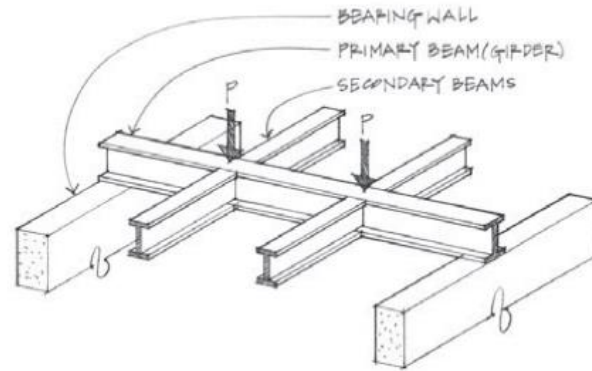

(a) Pictorial diagram of a loaded beam.

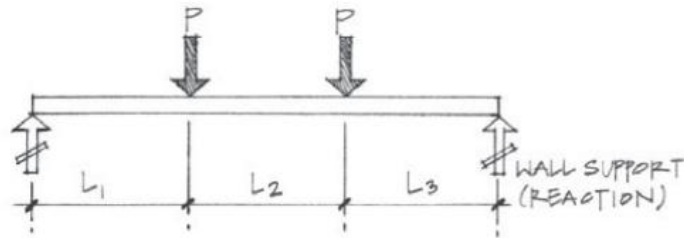

(b) FBD of the beam.

Figure 7.1 Steel beam with loads and support reactions.

KİRİŞ MESNETLENME TİPLERİ VE YÜKLER

Beams are often classified according to their support conditions. Figure 7.2 illustrates six major beam classifications.

(a) Basit kiriş

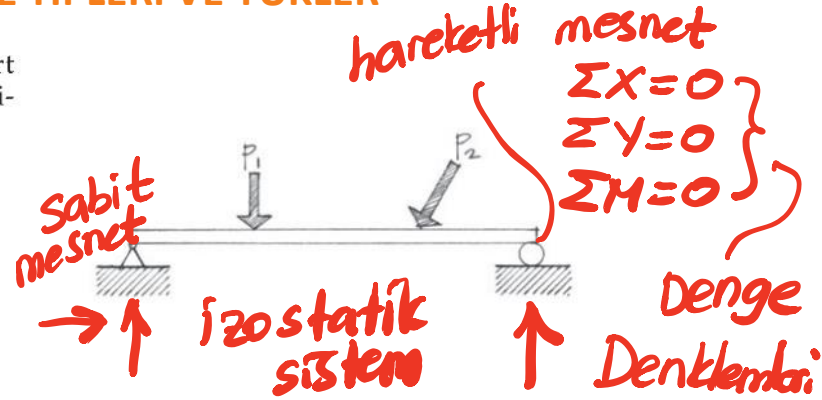

(b) Sürekli kiriş

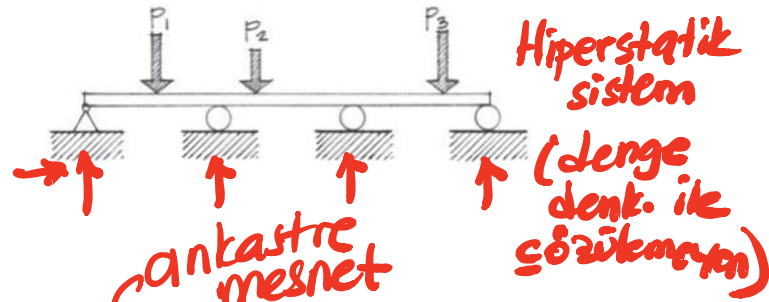

(c) Konsol kiriş

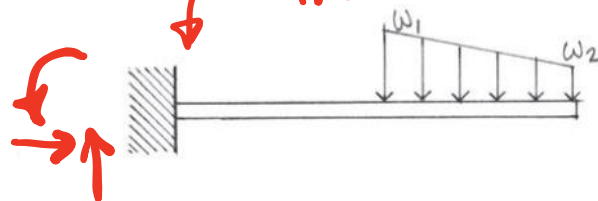

KİRİŞ MESNETLENME TİPLERİ VE YÜKLER

(d) Çıkmalı kiriş

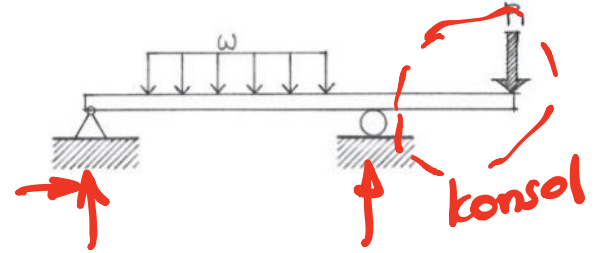

(e) Bir ucu ankastre bir ucu mafsallı mesnetli kiriş

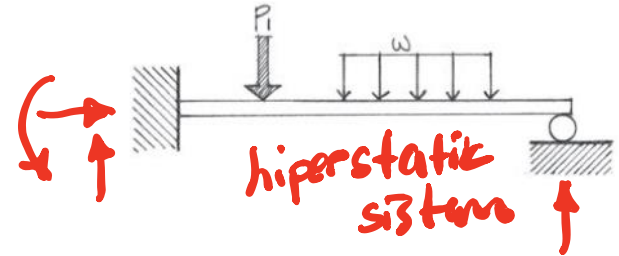

(f) İki ucu ankastre kiriş

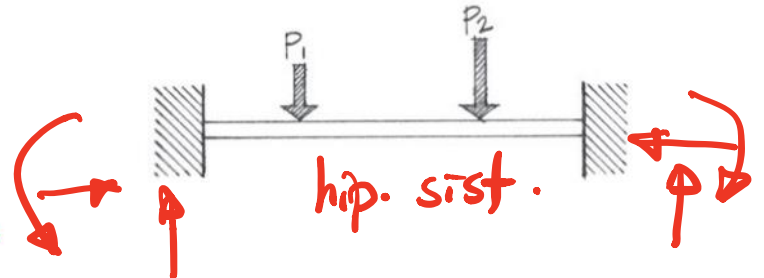
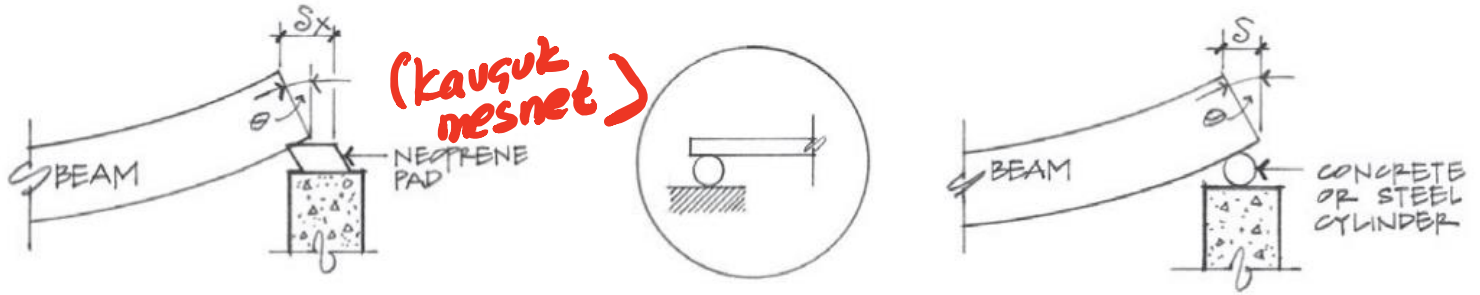

Figure 7.2 Classification based on support conditions.

MESNET TİPLERİ

Actual support and connection conditions for beams and columns are idealized as rollers, hinges (pins), or fixed. Figure 7.3 illustrates examples of common support/connection conditions found in practice.



(a) Kauçuk izolatör mesnet

(b) Beton/Çelik silindir mesnet

Hareketli mesnet örnekleri

Yük Akışı

- Surface-forming structure, such as structural **sheathing or decking** distributes the applied load to its supporting joists or beams in the form of a **distributed load**.
- Beams transfers the applied **distributed load** horizontally to supporting girders, trusses, columns, or bearing wall.
- **Tributary area** is the portion of a structure contributing to the load on a structural element or member.
- **Load strip** is the tributary area per unit length of a supporting structural member.
- **Tributary load** is the load on a structural element or member collected from its tributary area.
- **Bearing** refers to a point, surface, or mass that supports weight, especially the area of contact between a bearing member, as a beam or truss, and a column, wall, or other underlying support.
- **Anchorage** refers to the means for binding a structural member to another or to its foundation, often **to resist uplifting and horizontal forces**.

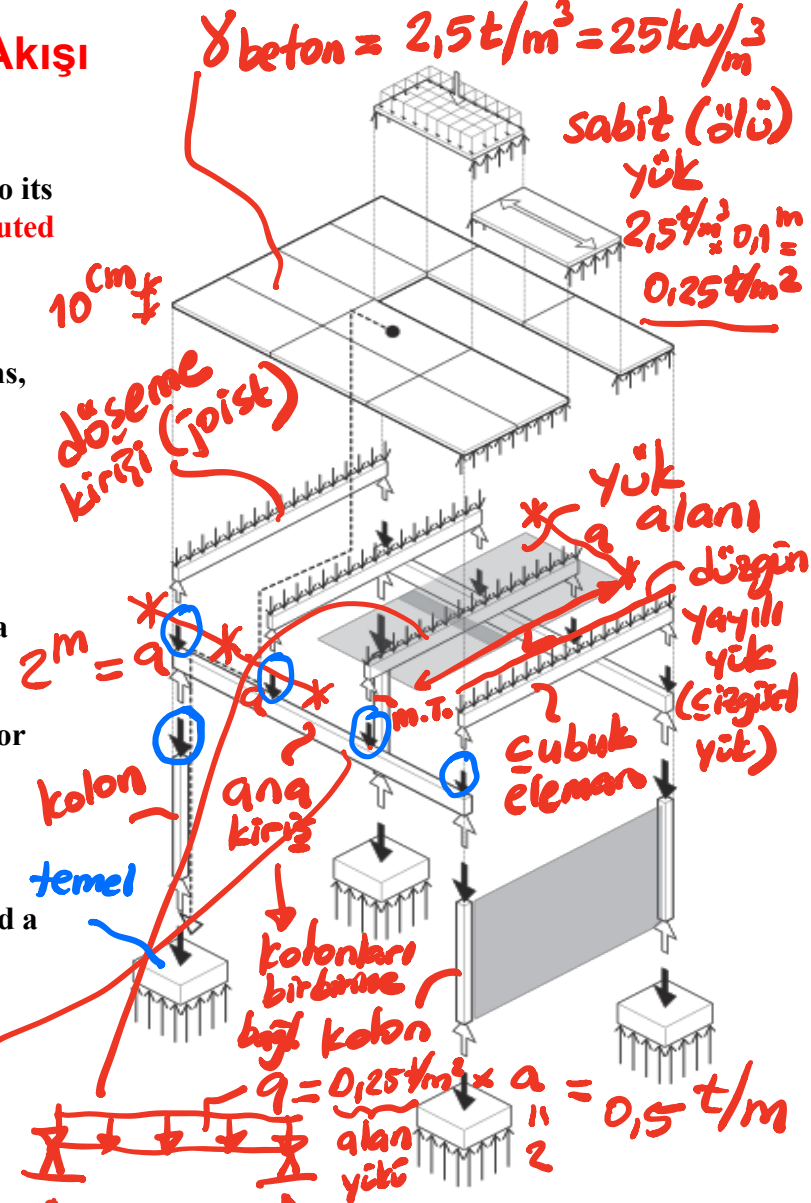

Yük Alanı

- Loads uniformly distributed over an area of roof or floor are assigned to individual members (rafters, joists, beams, girders) based on the concept of *distributive area*, *tributary area*, or *contributory area*.
- This concept typically considers the area that a member must support as being halfway between the adjacent similar members.
- The tributary width contributing to the load on a joist is 1/2 the distance between adjacent joists on both sides (which happens to be the joist spacing).
- Since wood joists are spaced relatively closely together, the load on the supporting beam is assumed to be uniform.
- The load condition of the joist and beam are shown below.

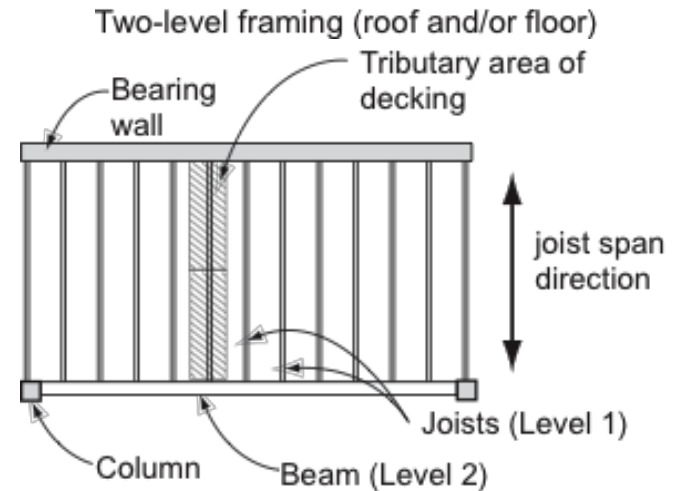
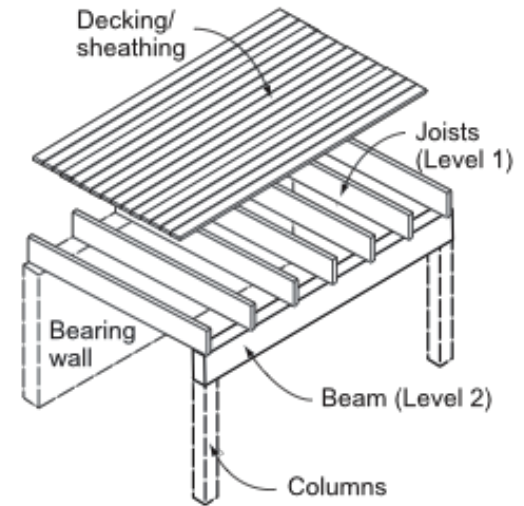

Framing plan

Deck loads
LL+DL (lb./ft. or N/m)

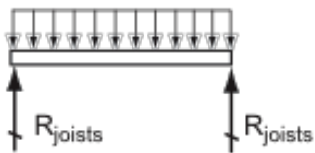

(a) FBD - joists: level 1

Uniform joist loads
LL+DL (lb./ft. or N/m)

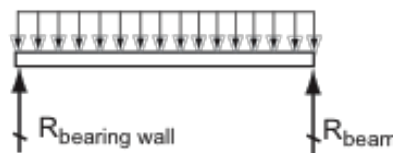

(b) FBD - beam: level 2

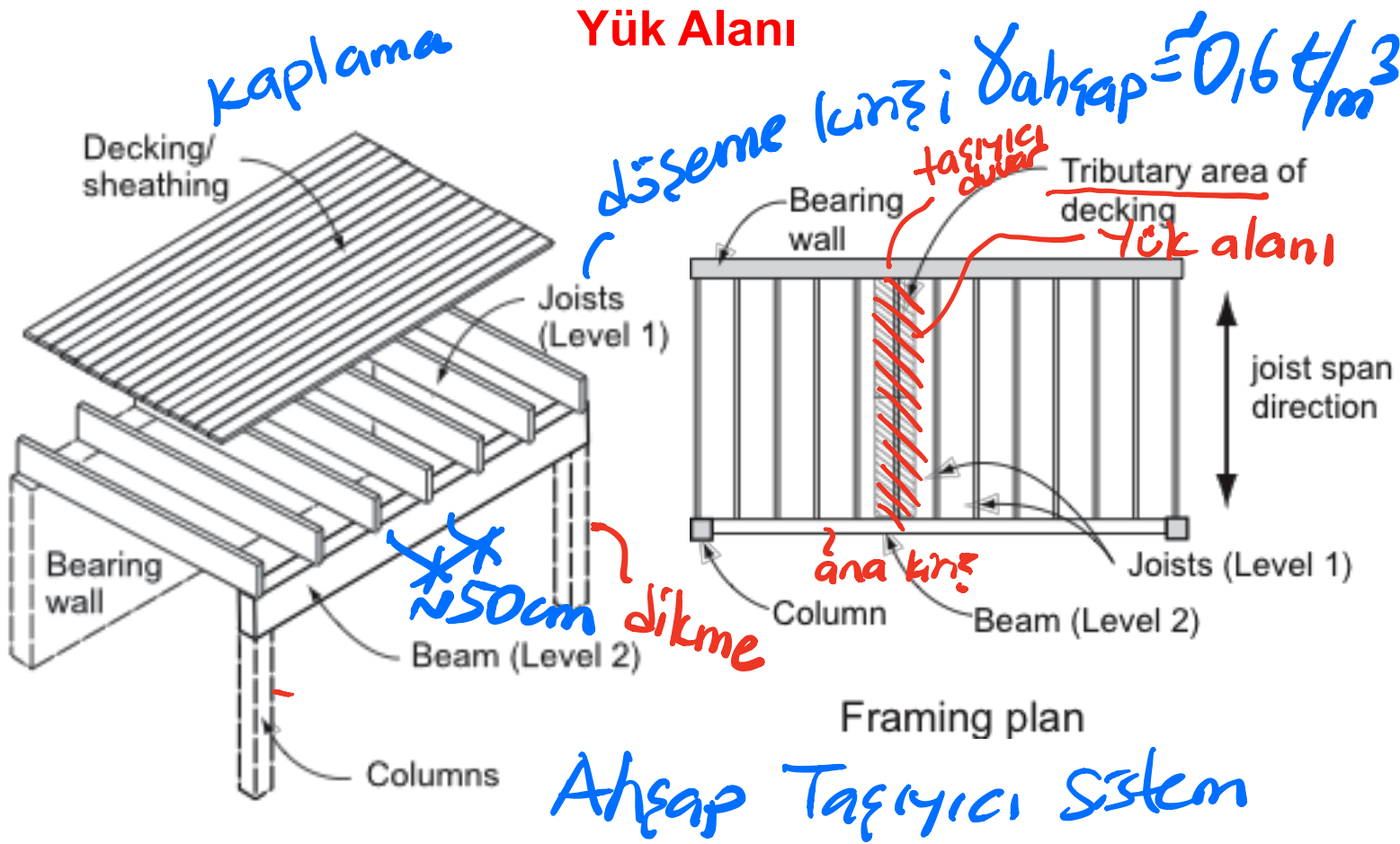

Two-level framing (roof and/or floor)

Yük Alanı

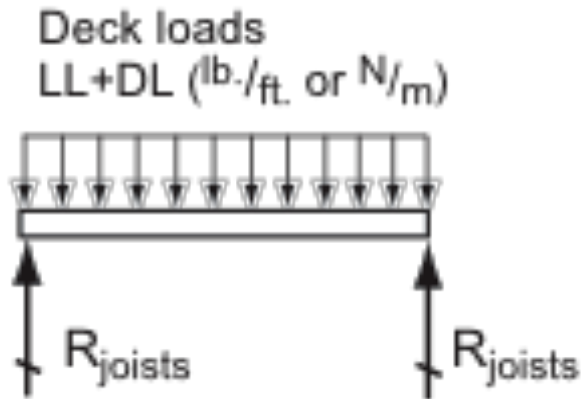

(a) FBD - joists: level 1

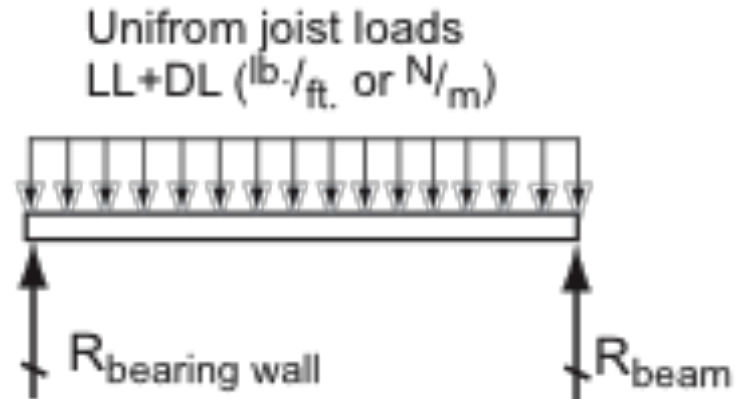

(b) FBD - beam: level 2

MESNET TİPLERİ

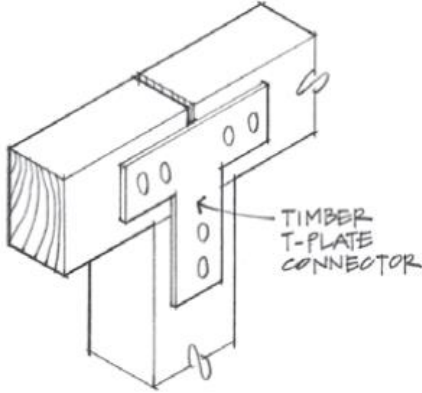

(c) Ahşap dikme-kiriş birleşimi

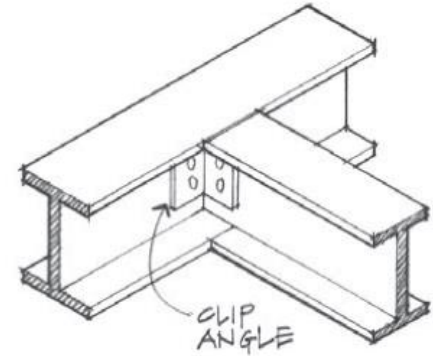
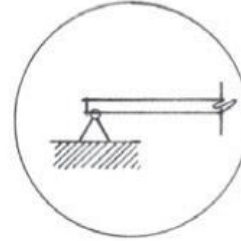

(d) Çelik kiriş-kiriş birleşimi

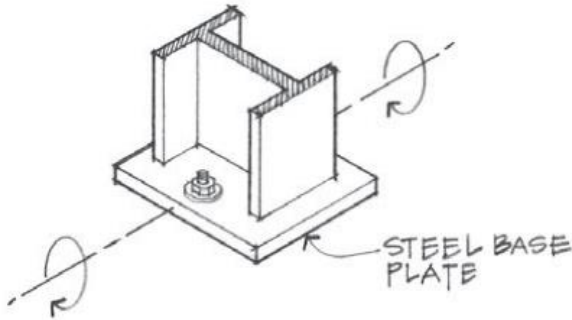

(e) Çelik kolon-temel birleşimi

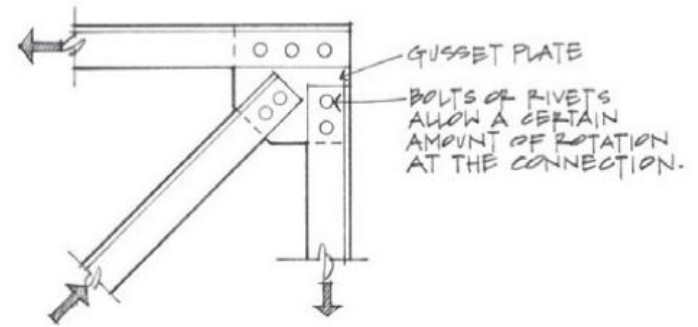

(f) Çelik kafes sistem düğüm noktası detayı

MESNET TİPLERİ

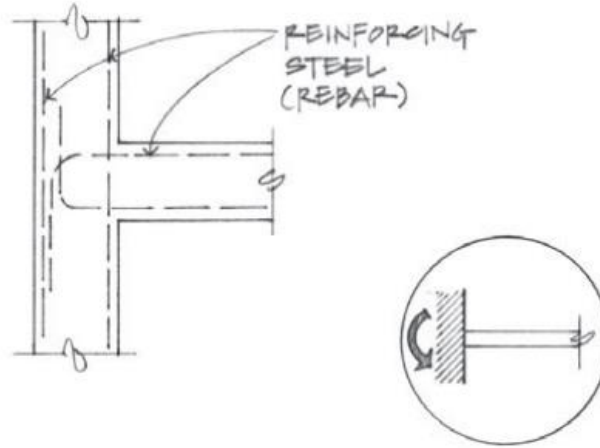

(g) Betonarme kiriş-kolon birleşimi

Ankastre Mesnet Örnekleri

MESNET TIPLERİ

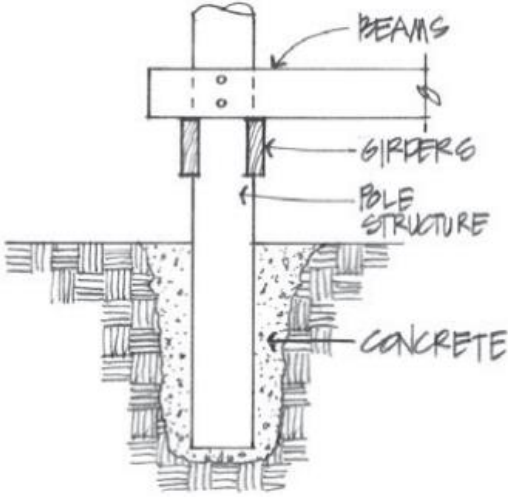

(h) Ahşap dikme-temel birleşimi

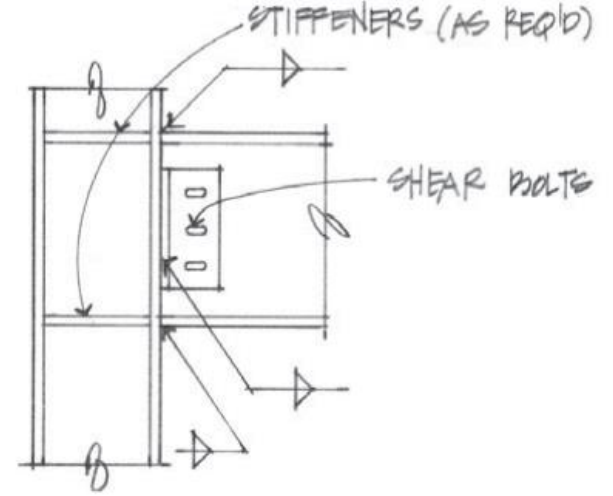

(i) Çelik kolon-kiriş birleşimi

Ankastre Mesnet Örnekleri

YÜK TIPLERİ

Figure 7.4 illustrates the four fundamental types of loads that can act on a beam.

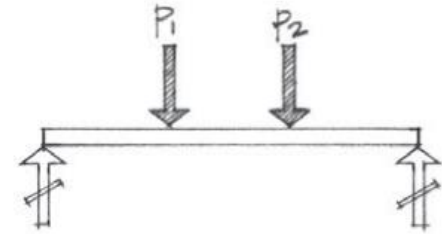
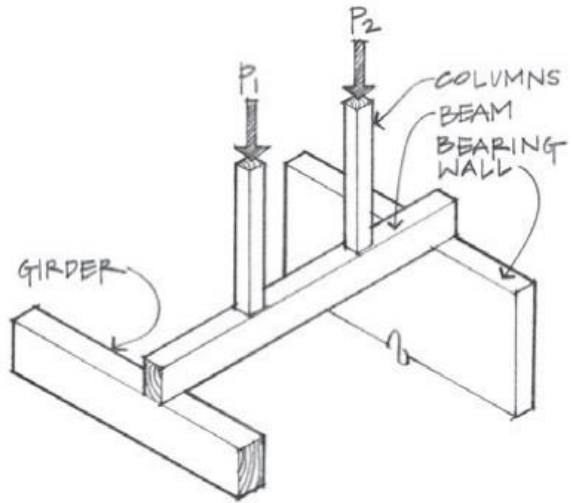

(a) Tekil yük

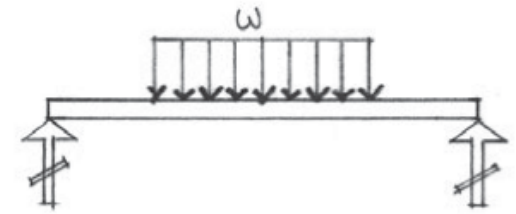
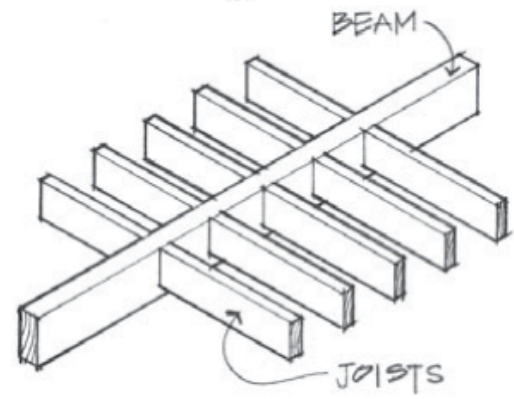

(b) Düzgün yayılı yük

YÜK TİPLERİ

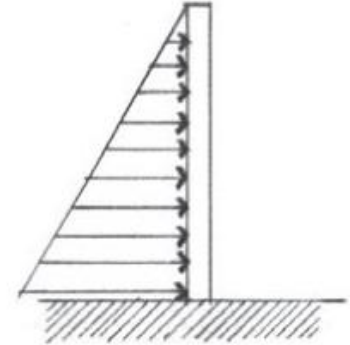
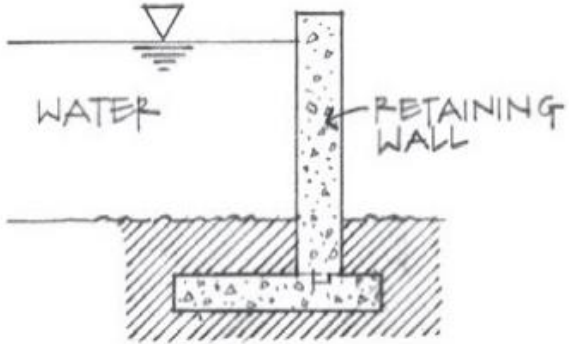

(c) Üçgen yayılı yük

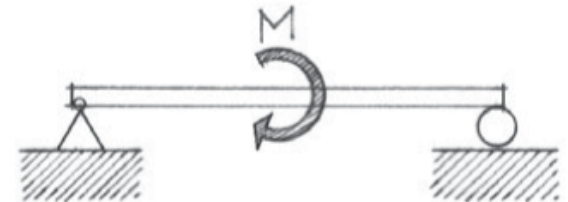
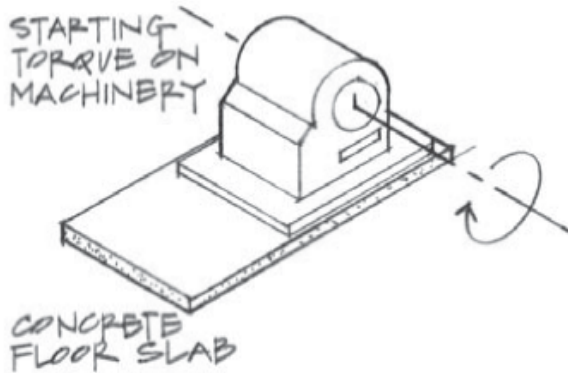

(d) Tekil moment

TAŞIYICI ELEMANLARDA DEFORMASYONLAR

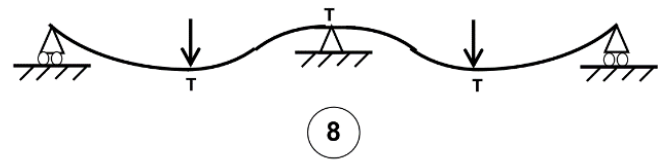
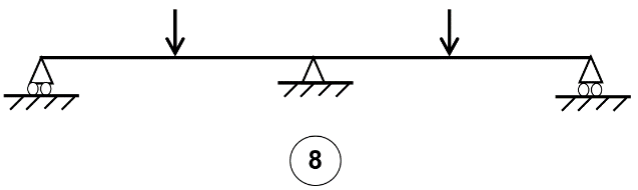
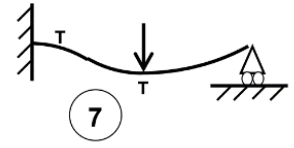
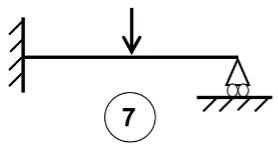
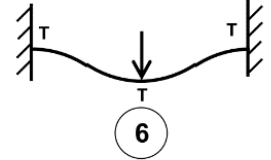
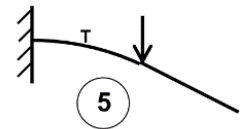
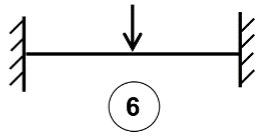
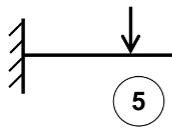
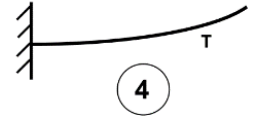
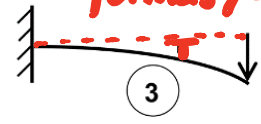
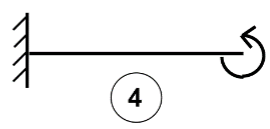
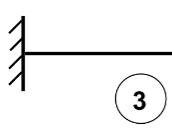
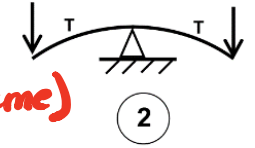
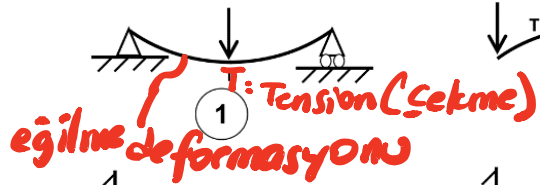
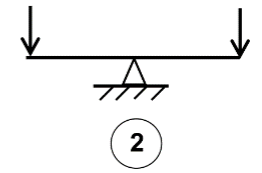
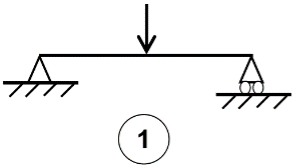

Tekil Yük ile yüklü kirişler

TAŞIYICI ELEMANLARDA DEFORMASYONLAR

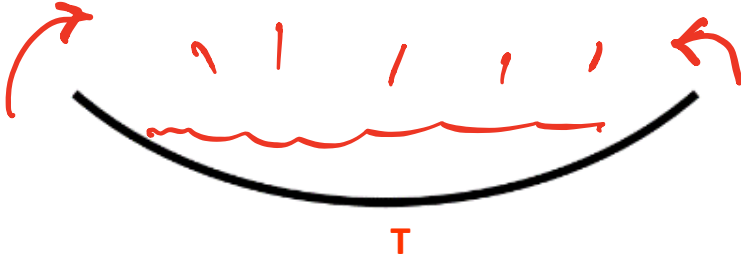

Kirişin alt yüzünde çekme etkileri oluşur

(a) Pozitif Eğilme

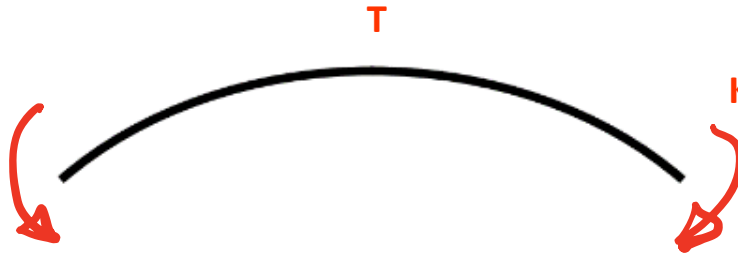

Kirişin üst yüzünde çekme etkileri oluşur

(b) Negatif Eğilme

NORMAL KUVVET (EKSENEL KUVVET)

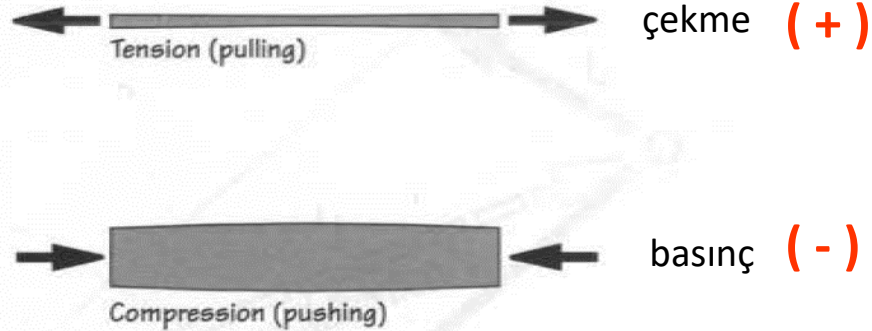
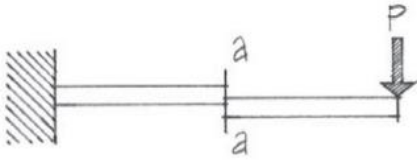

Figure 1.11 Tension and compression represented as bodies acted on by vectors.

“The remarkable, inherent simplicity of nature allows the structure to perform its task through two elementary actions only: pulling and pushing.”

—MARIO SALVADORI

KESME KUVVETİ



(+) Kesme Etkisi

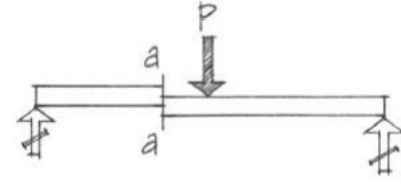

(+) Kesme Etkisi

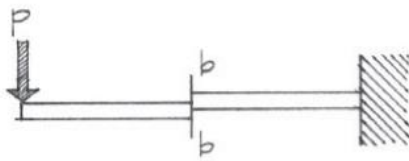

(-) Kesme Etkisi

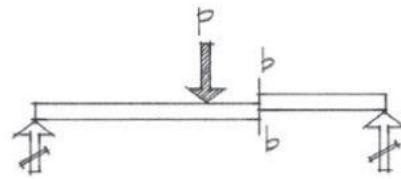

(-) Kesme Etkisi

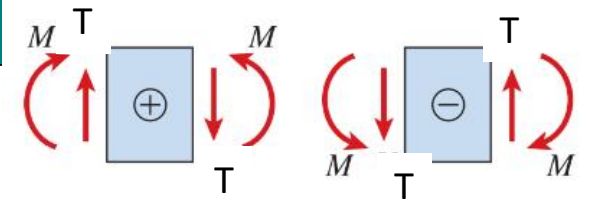

T ve M için işaret kaidesi

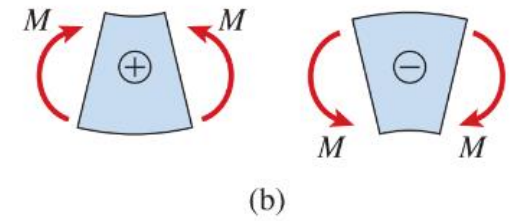
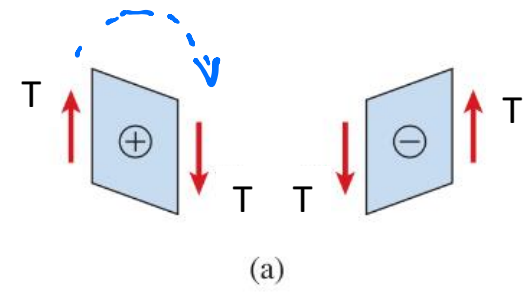

T ve M etkisi altında kirişte oluşan deformasyonlar

EĞİLME MOMENTİ

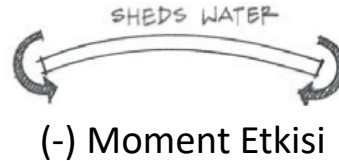
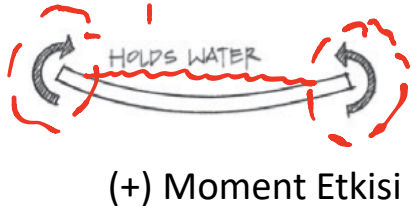
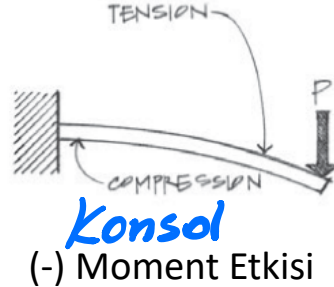
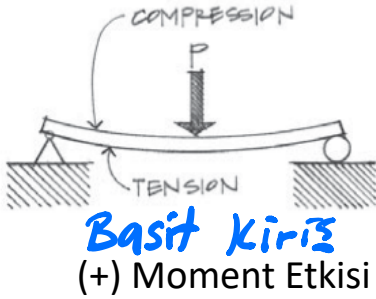
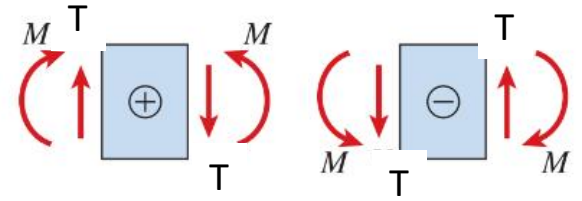
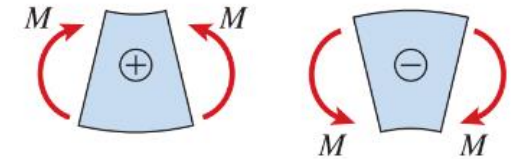
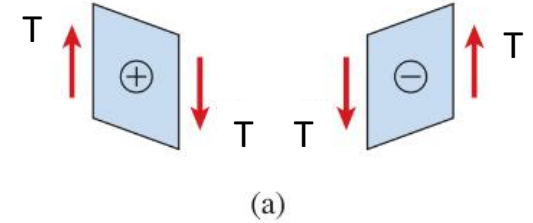

Figure 7.7 Sign convention for moment.

Positive moment generates a curvature that tends to hold water (concave-upward curvature), whereas negative moment causes a curvature that sheds water (concave-downward curvature).



T ve M için işaret kaidesi



T ve M etkisi altında kirişte oluşan deformasyonlar

EĞİLME DEFORMASYONU (T:Tension/Çekme, C:Compression/Basınç)

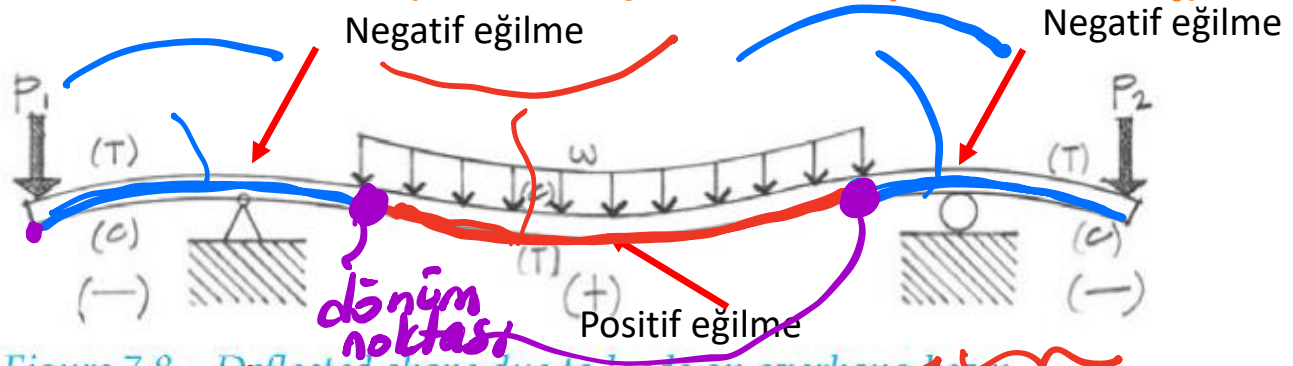

Figure 7.8 Deflected shape due to loads on overhang beam.

konsol
(çıkma)

Açıklık

konsol
(çıkma)

The overhang beam shown in Figure 7.8 exhibits a changing curvature that results in negative to positive to negative moments. The implication here is that the beam span includes one or more transverse sections where the bending moment is zero to accommodate the required sign change. Such a section, termed the *inflection point* or *point of inflection*, is almost always present in overhang and multiple-span beams.

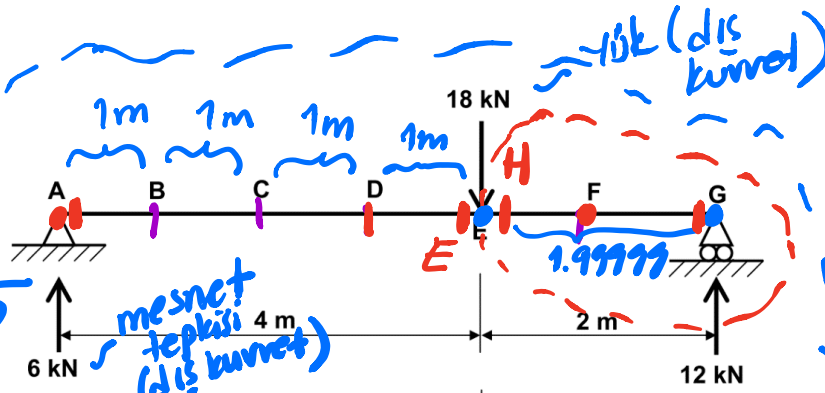

Free body diagram of segment AB:

$$\sum X = 0 \rightarrow N_B = 0$$

$$\sum Y = 0 \rightarrow 6 - T_B = 0 \rightarrow T_B = 6 \text{ kN}$$

$$\sum M_B = 0 \rightarrow +6 \cdot 1 - M_B = 0 \rightarrow M_B = 6 \text{ kNm}$$

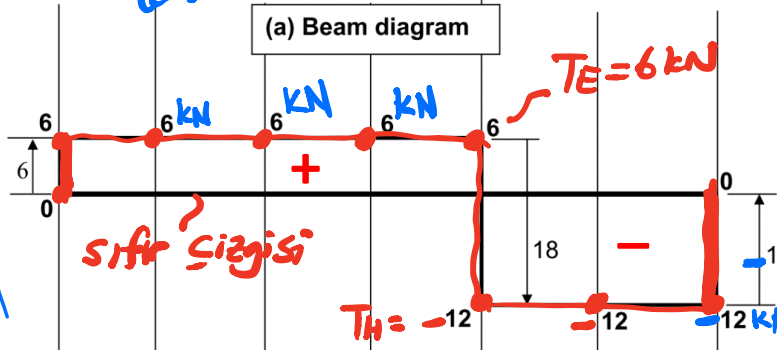

Free body diagram of segment AD:

$$\sum X = 0 \rightarrow N_D = 0$$

$$\sum Y = 0 \rightarrow 6 - T_D = 0 \rightarrow T_D = 6 \text{ kN}$$

$$\sum M_D = 0 \rightarrow 6 \cdot 3 - M_D = 0 \rightarrow M_D = 18 \text{ kNm}$$

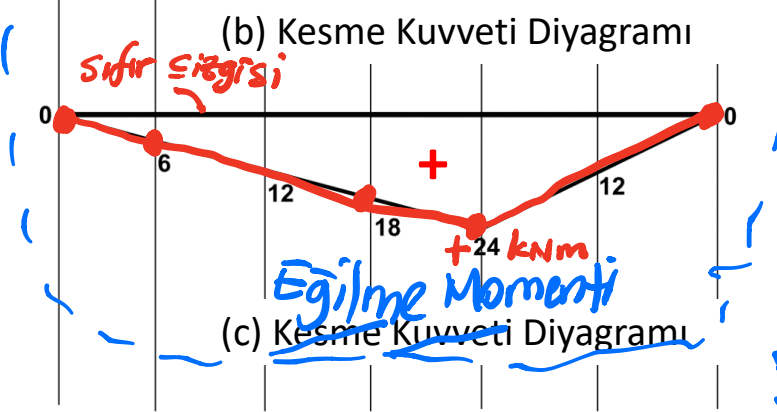

Free body diagram of segment EH:

$$\sum X = 0 \rightarrow N_H = 0$$

$$\sum Y = 0 \rightarrow T_H + 12 = 0 \rightarrow T_H = -12 \text{ kN}$$

$$\sum M_H = 0 \rightarrow +12 \cdot 2 - M_H = 0 \rightarrow M_H = 24 \text{ kNm}$$

düğüün yayıllı yük

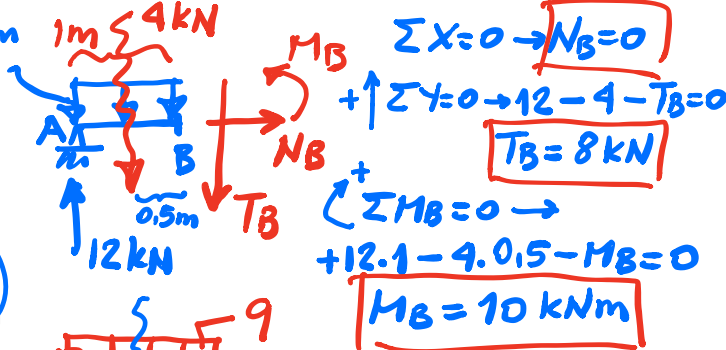
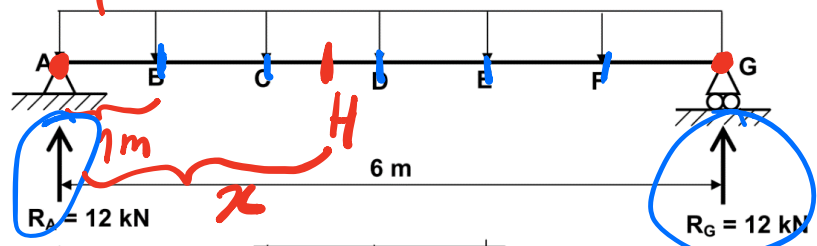

(a) Beam diagram

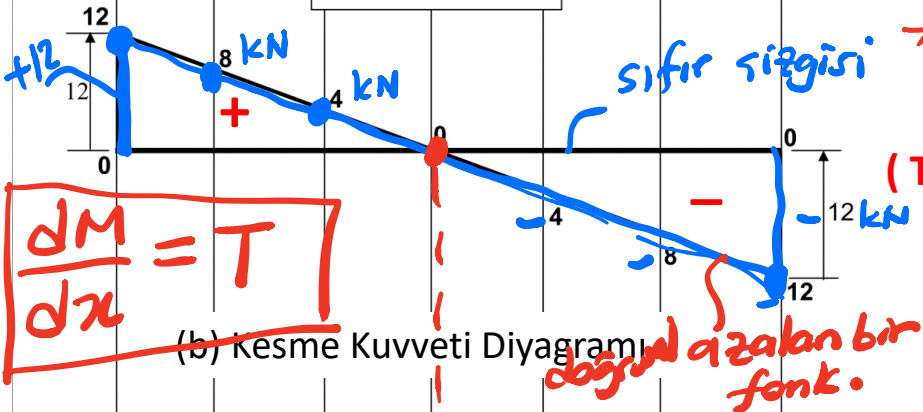

(b) Kesme Kuvveti Diyagramı

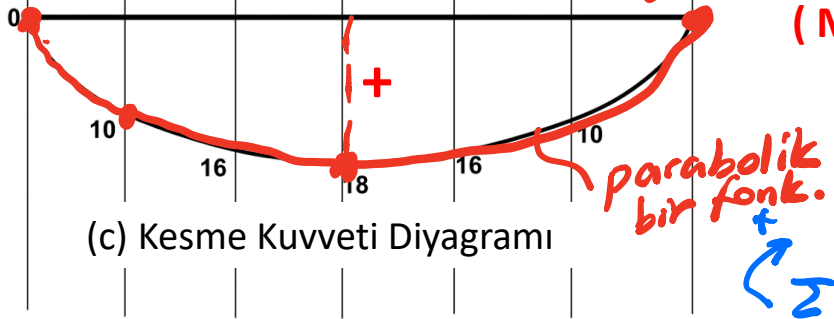
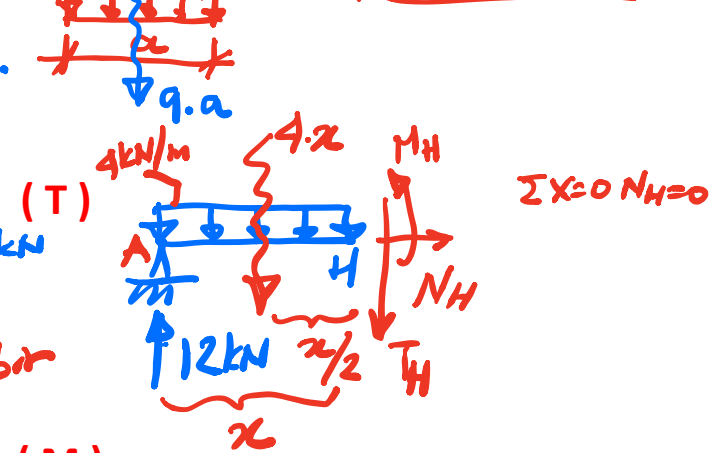

(c) Kesme Kuvveti Diyagramı

Fig. 16.10 Example 16.3: Shear force and bending moment diagrams: uniformly distributed load example.

Tekil Yük Etkisindeki Basit Kirişte Kesme Kuvveti Diyagramı

Kuvvet yönünde hareket ederek diyagram çizilir. Tekil kuvvetler arasında kesme Kuvveti değişimi sabittir. A noktasında 6kN yukarı doğru, devamında 18kN yüke kadar Kesme kuvveti değişmeden devam edilir. 18kN kuvvet aşağı doğru olduğundan kesme Kuvvetinde 18kN aşağı doğru bir değişim olacaktır. 12kN tekil kuvvete kadar diyagram Sabit olarak devam eder. 12kN yukarı yönlü kuvvet ile diyagram tamamlanır.

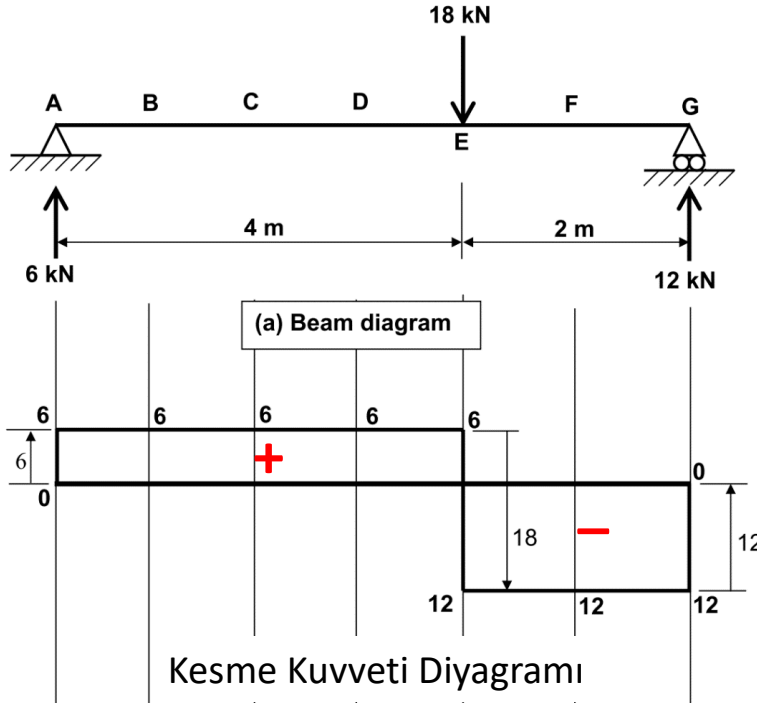

$$\frac{dM}{dx} = T \text{ ise}$$
$$\int dM = \int T \cdot dx$$
$$(T) \int M = \int T \cdot dx$$

Eğilme Momenti Diyagramı (Kesme kuvveti diyagramı
altındaki alan eğilme momenti değerlerini verir)

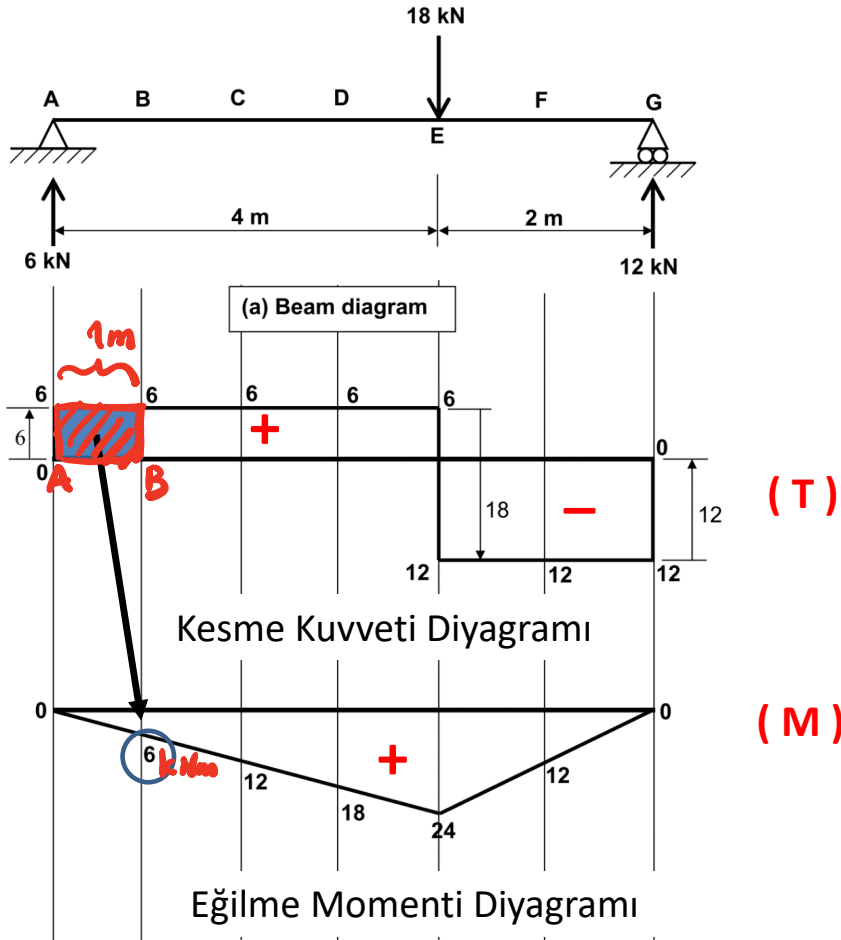

Eğilme Momenti Diyagramı (Kesme kuvveti diyagramı
altındaki alan eğilme momenti değerlerini verir)

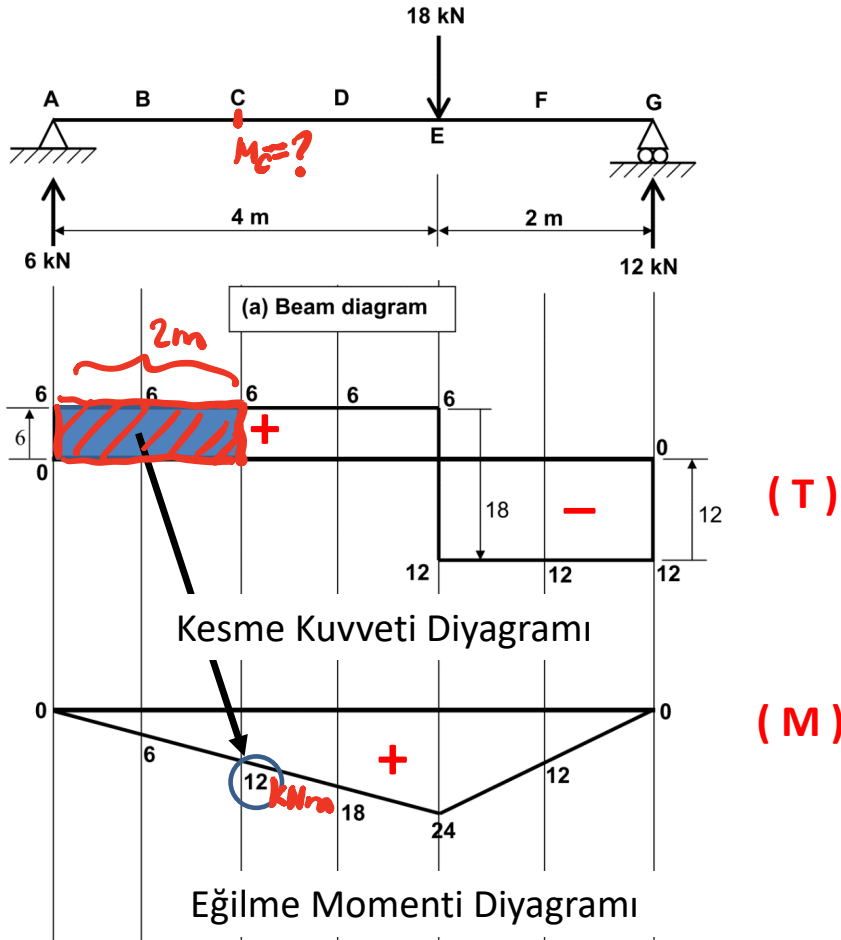

Eğilme Momenti Diyagramı (Kesme kuvveti diyagramı
altındaki alan eğilme momenti değerlerini verir)

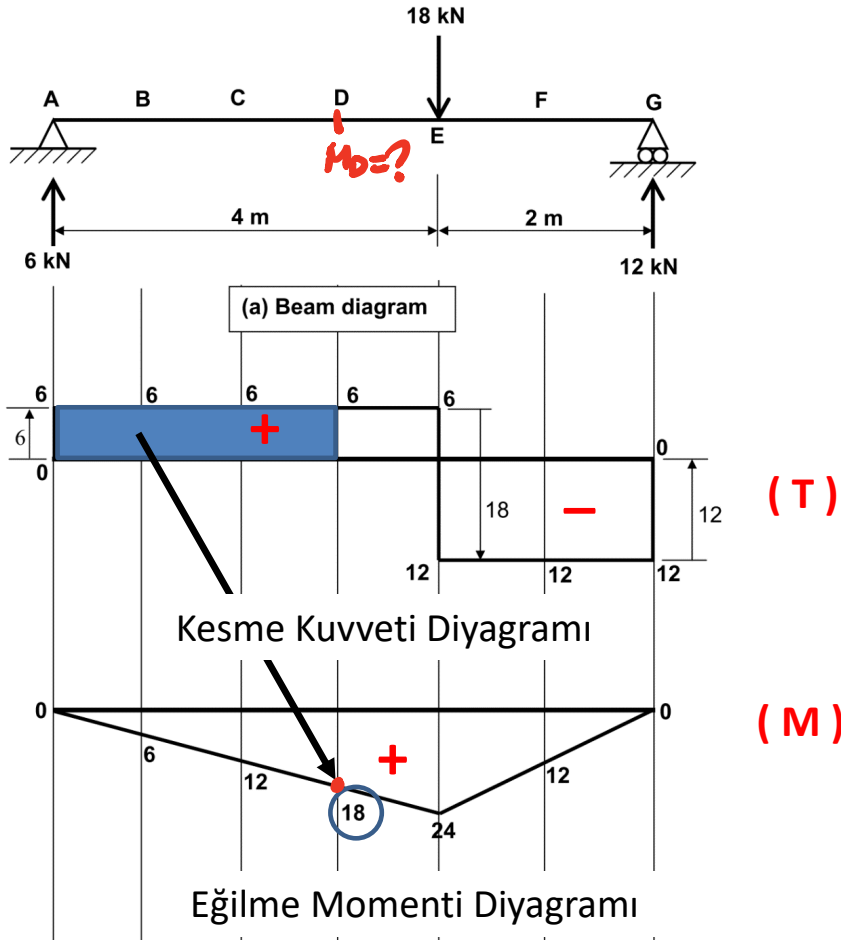

Eğilme Momenti Diyagramı (Kesme kuvveti diyagramı
altındaki alan eğilme momenti değerlerini verir)

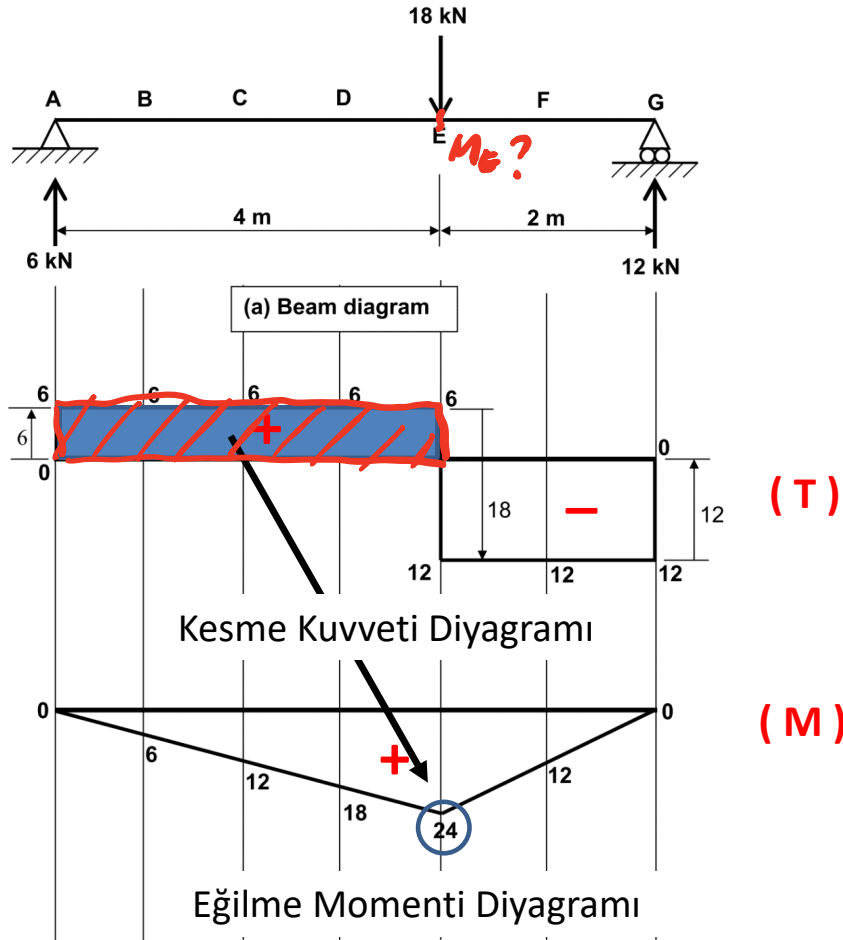

Eğilme Momenti Diyagramı (Kesme kuvveti diyagramı
altındaki alan eğilme momenti değerlerini verir)

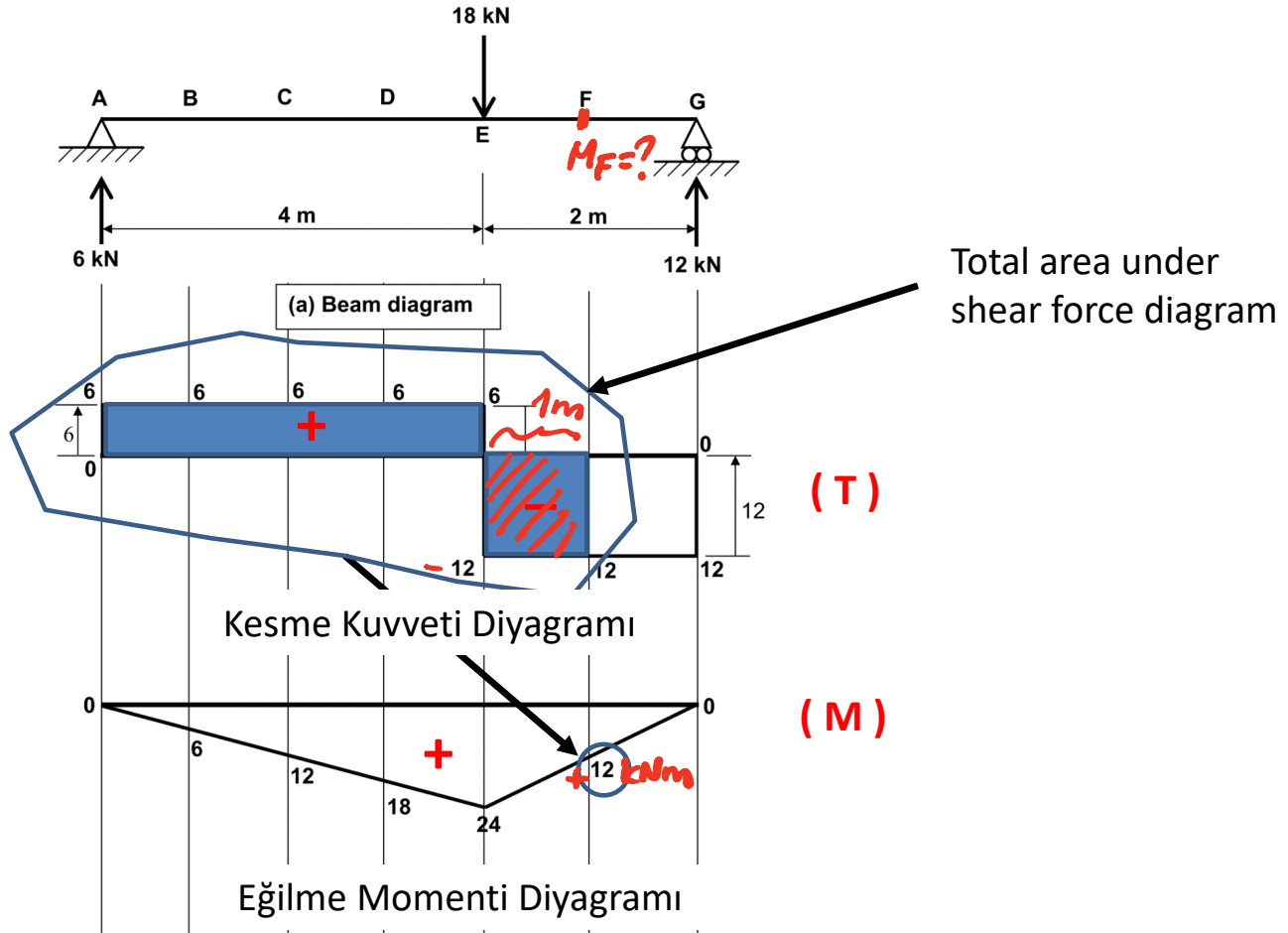

Eğilme Momenti Diyagramı (Kesme kuvveti diyagramı
altındaki alan eğilme momenti değerlerini verir)

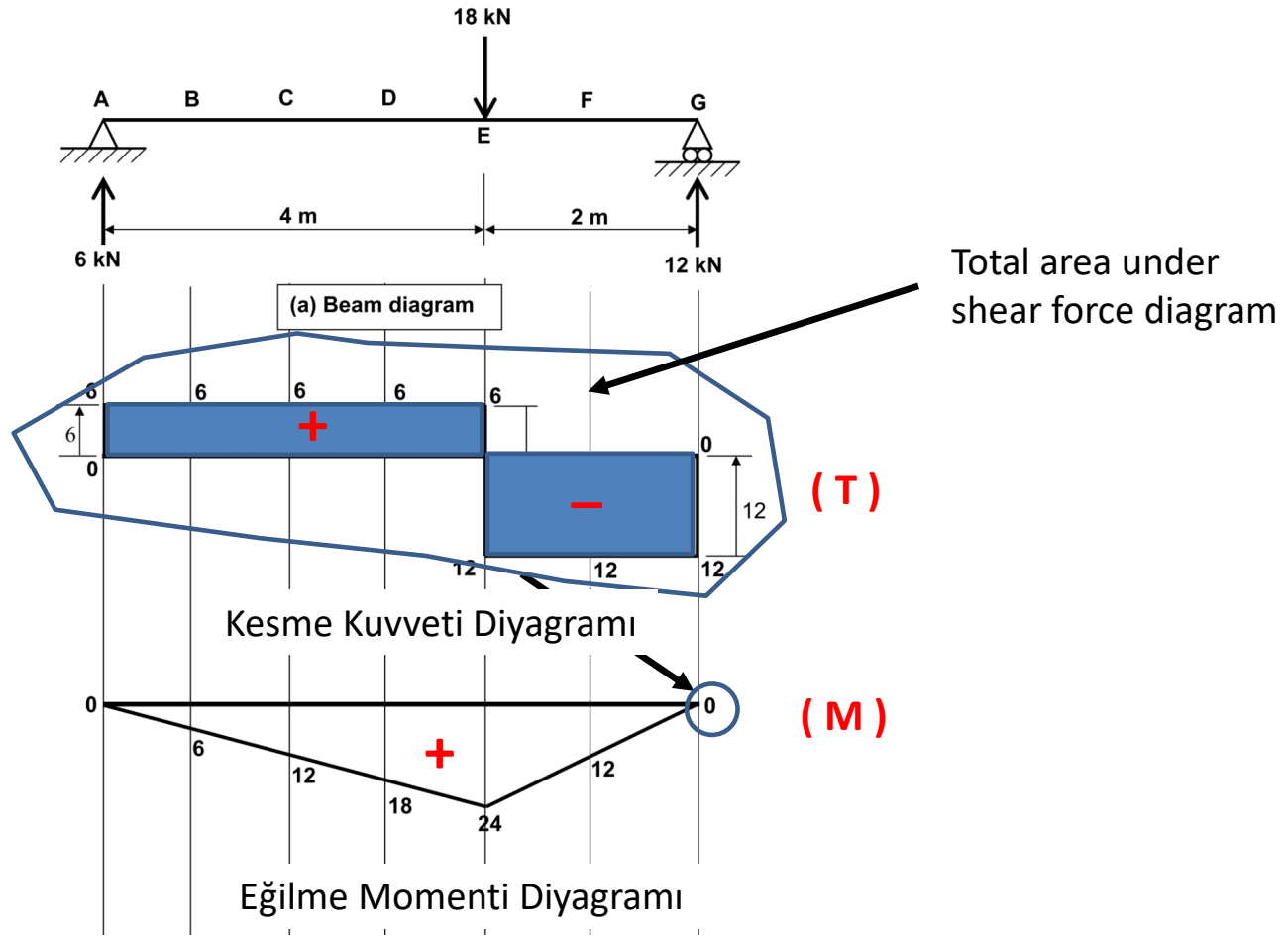

Kesme Kuvveti ve Eğilme Momenti Diyagramları

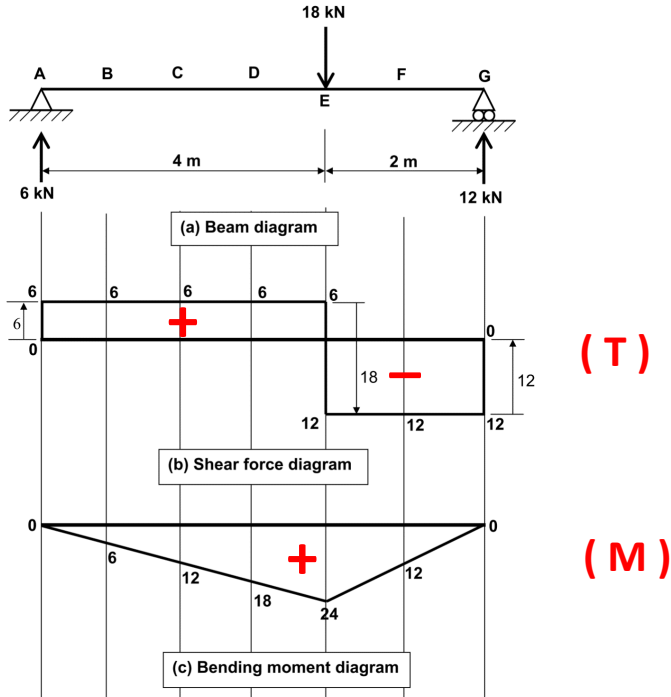

- Tekil yük etkisindeki sistemlerde kesme kuvveti diyagramı basamak şeklinde, moment Diyagramı doğrusal olarak değişir.
- Kesme kuvvetideğerleri sıfır çizgisi üzerinde pozitif, eğilme momentleri sıfır çizgisi Altında pozitif olarak gösterilir.

Düzgün Yayılı Yük Etkisindeki Basit Kirişte Kesme Kuvveti Diyagramı

Yayılı yük kesme kuvveti diyagramında doğrusal olarak azalmaya sebep olur. Azalma değeri Yayılı yük şiddeti ile yükün açıklığının çarpımı ($4\text{kN/m} \times 6\text{m} = 24\text{kN}$) kadardır.

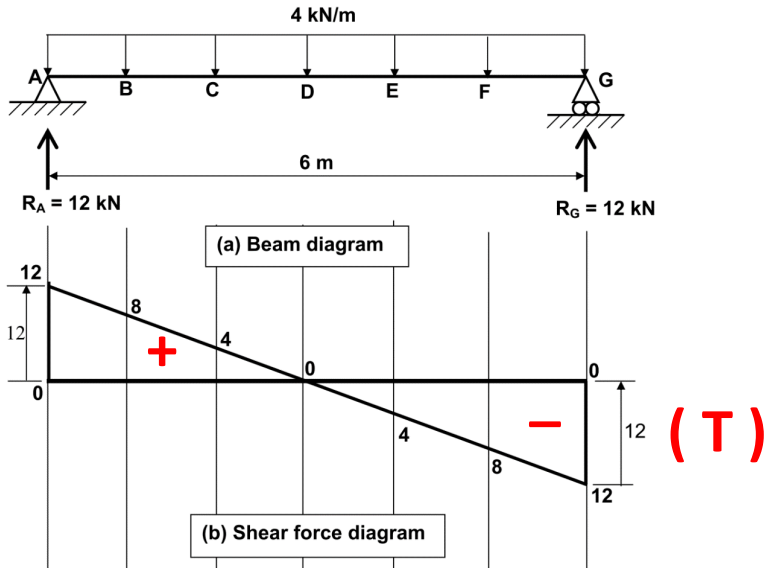

Mukavemet

İç Kuvvet Diyagramları

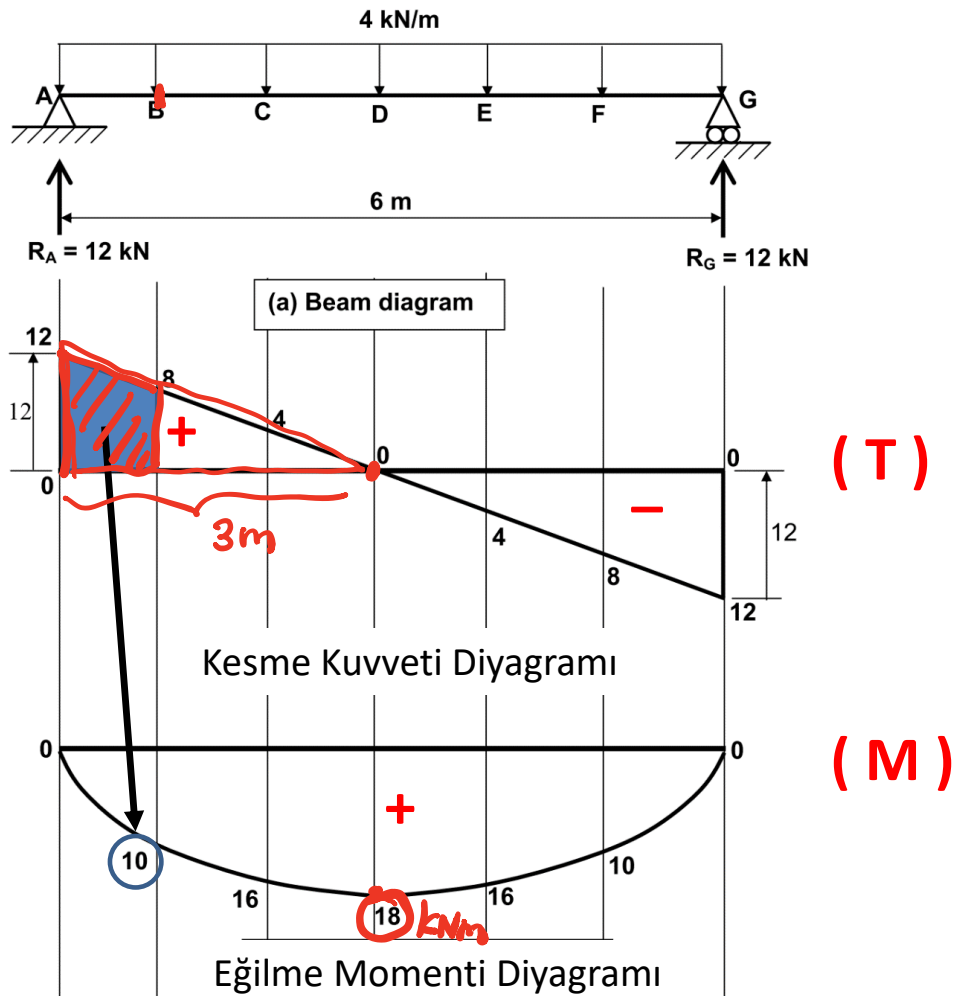

$$M_B = (12+8) \times 0.5 \times 1 = 10 \text{ kNm}$$

Mukavemet

İç Kuvvet Diyagramları

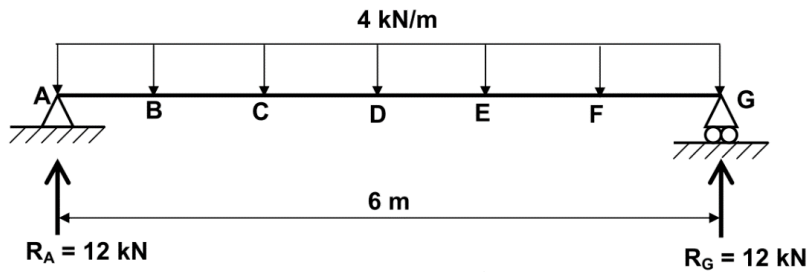

(a) Beam diagram

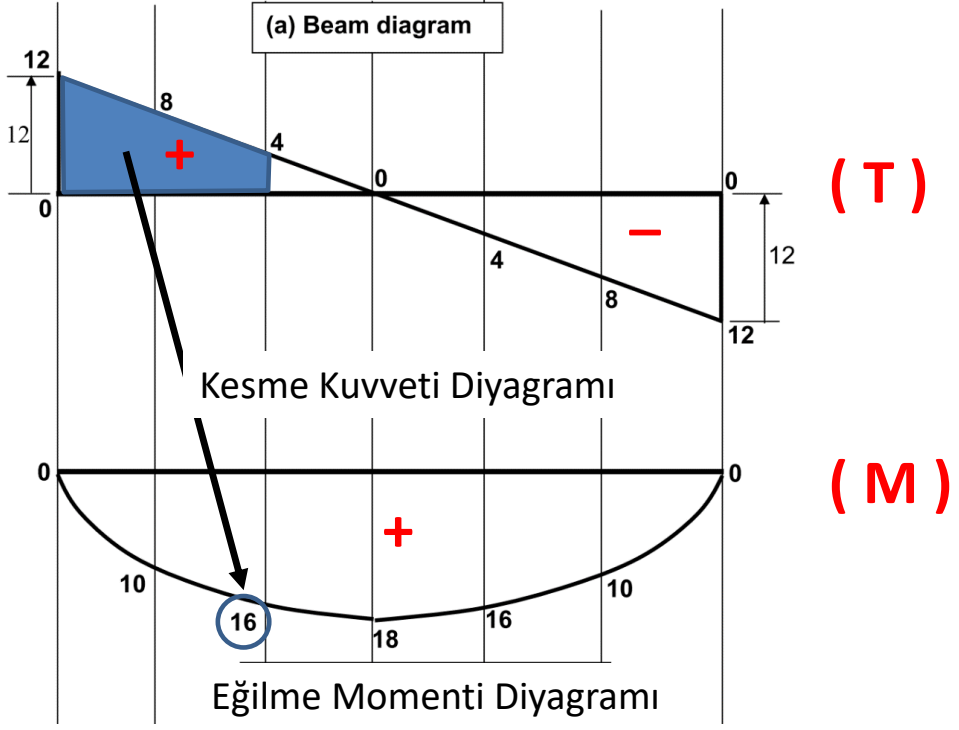

$$M_C = 10 + (8 + 4) \times 0.5 \times 1 = 16 \text{ kNm}$$

Mukavemet İç Kuvvet Diyagramları

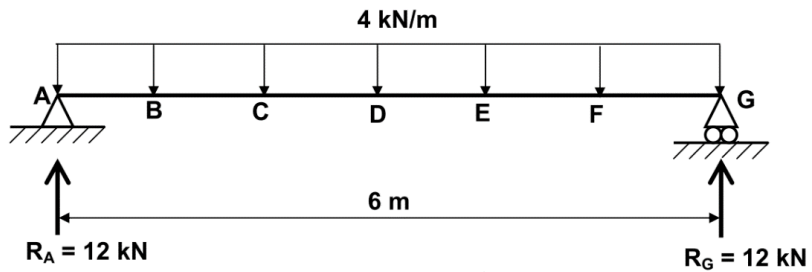

(a) Beam diagram

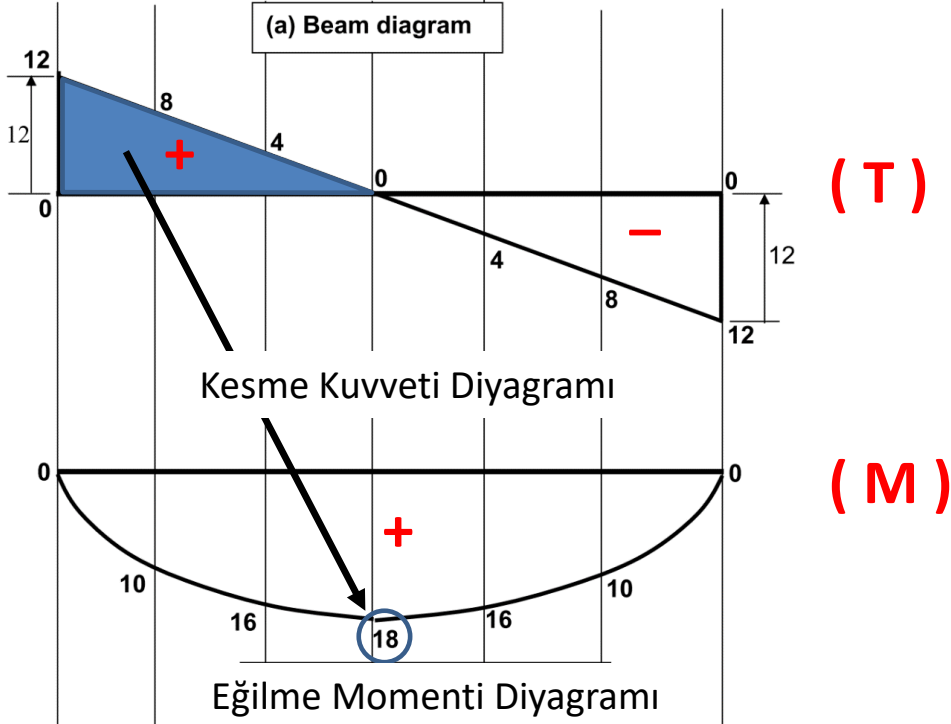

$$M_D = 16 + 4 \times 1 \times 0.5 = 18 \text{ kNm}$$

Mukavemet

İç Kuvvet Diyagramları

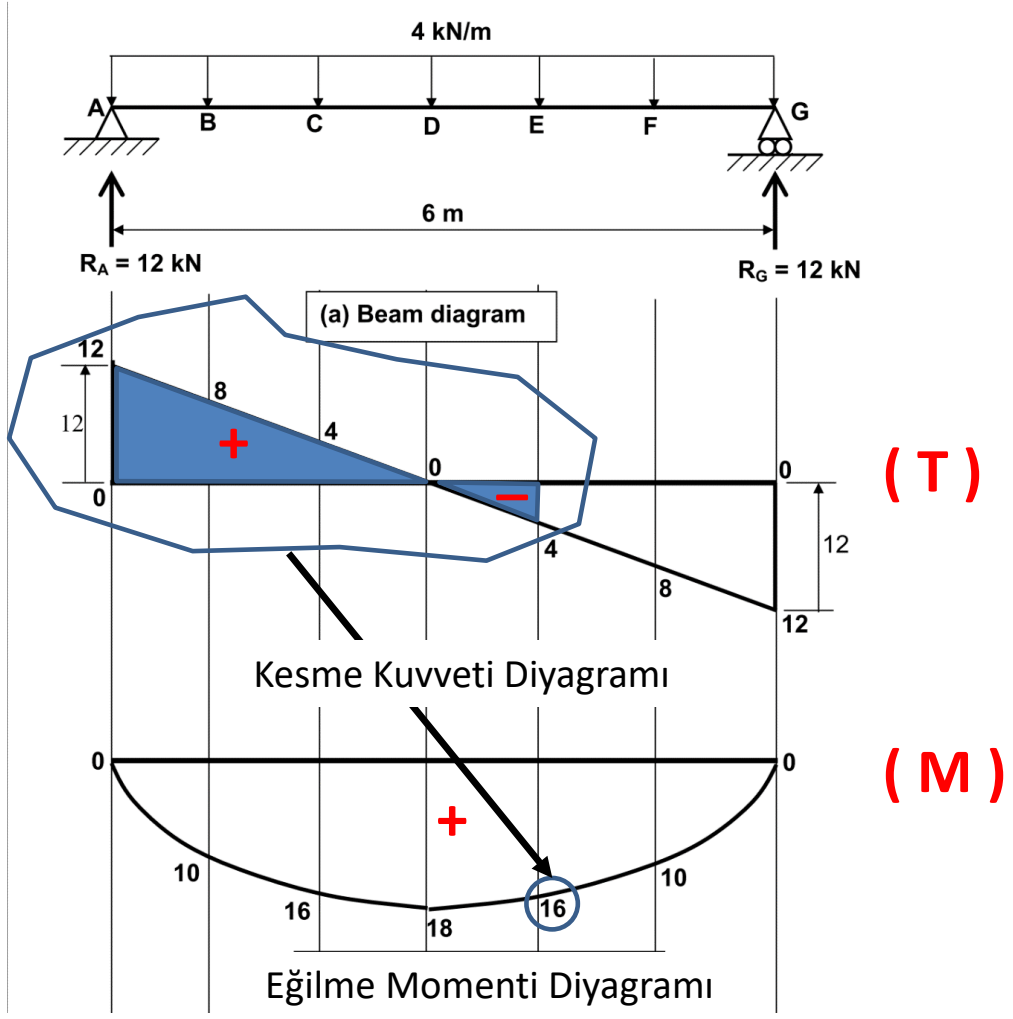

$$M_E = 18 - 4 \times 1 \times 0.5 = 16 \text{ kNm}$$

Mukavemet

İç Kuvvet Diyagramları

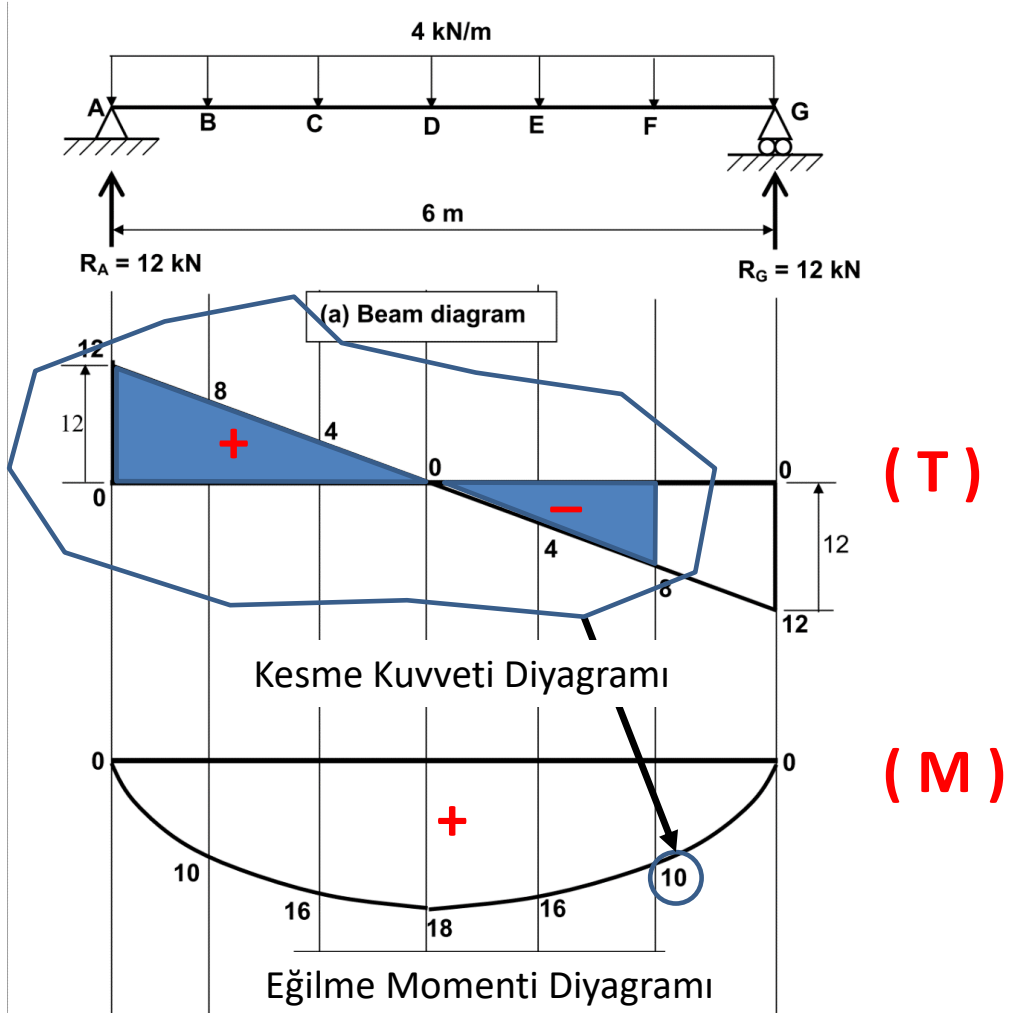

$$M_F = 16 - (4+8) \times 1 \times 0.5 = 10 \text{ kNm}$$

Mukavemet

İç Kuvvet Diyagramları

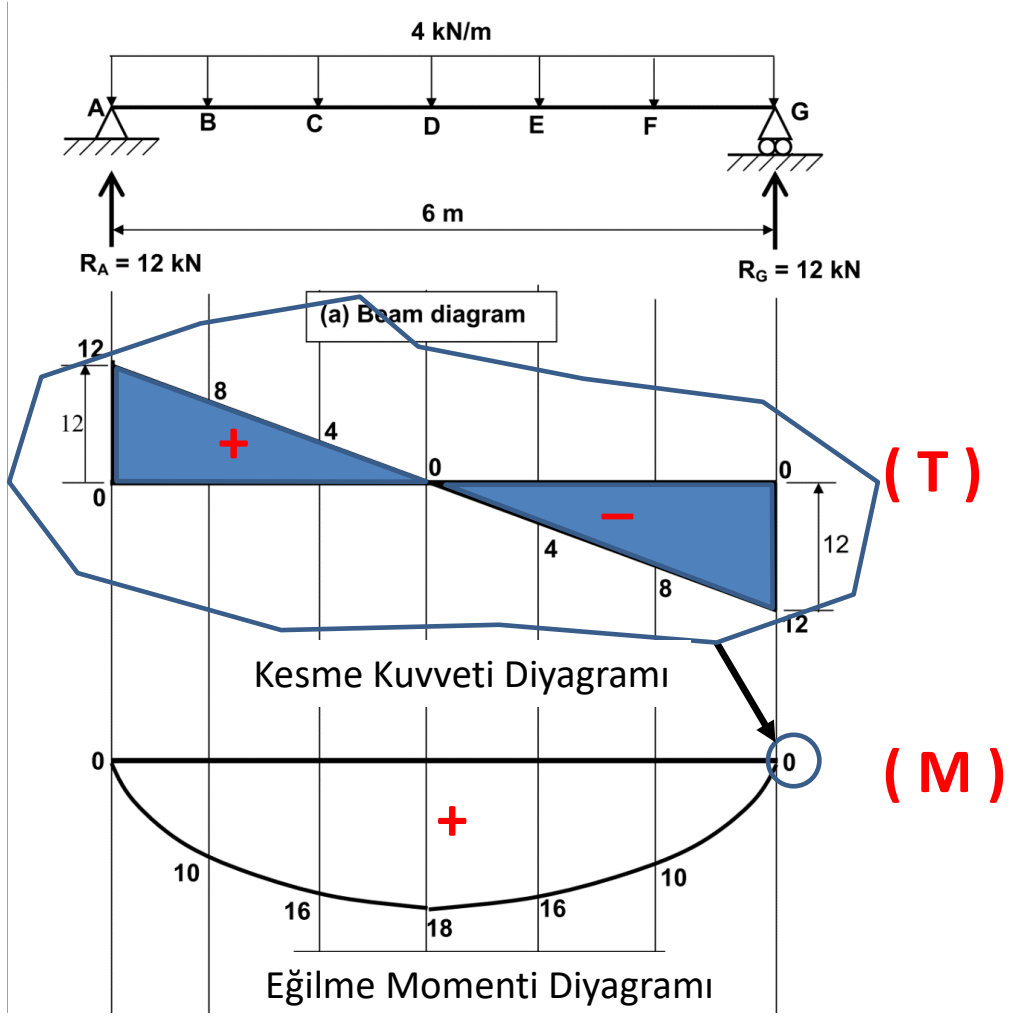

ÖRNEK:

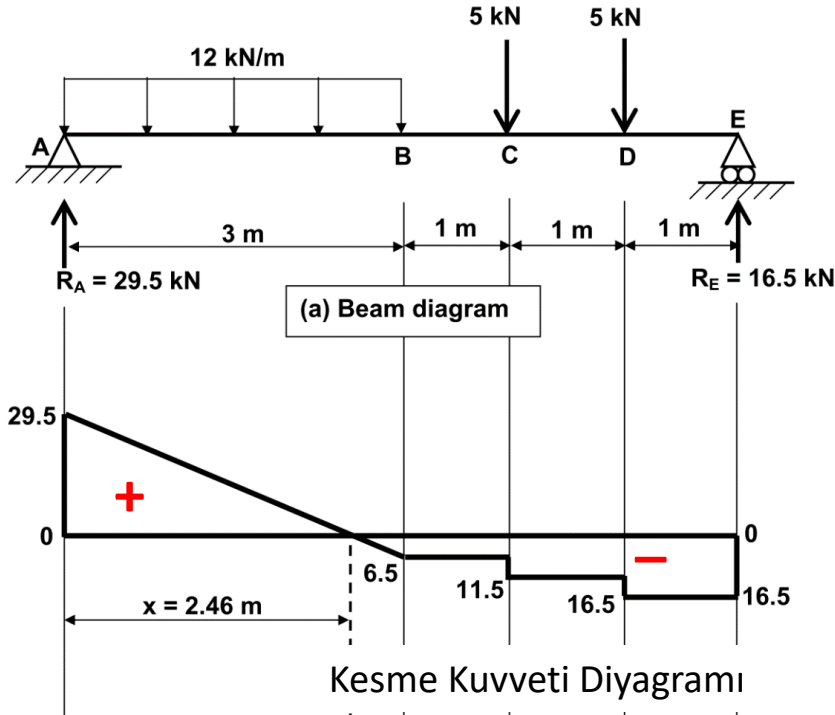

$$V_B = 29.5 - 12 \times 3 = -6.5 \text{ kN}$$

$$V_C = -6.5 - 5 = -11.5 \text{ kN}$$

$$V_D = -11.5 - 5 = -16.5 \text{ kN}$$

(T)

Mukavemet

İç Kuvvet Diyagramları

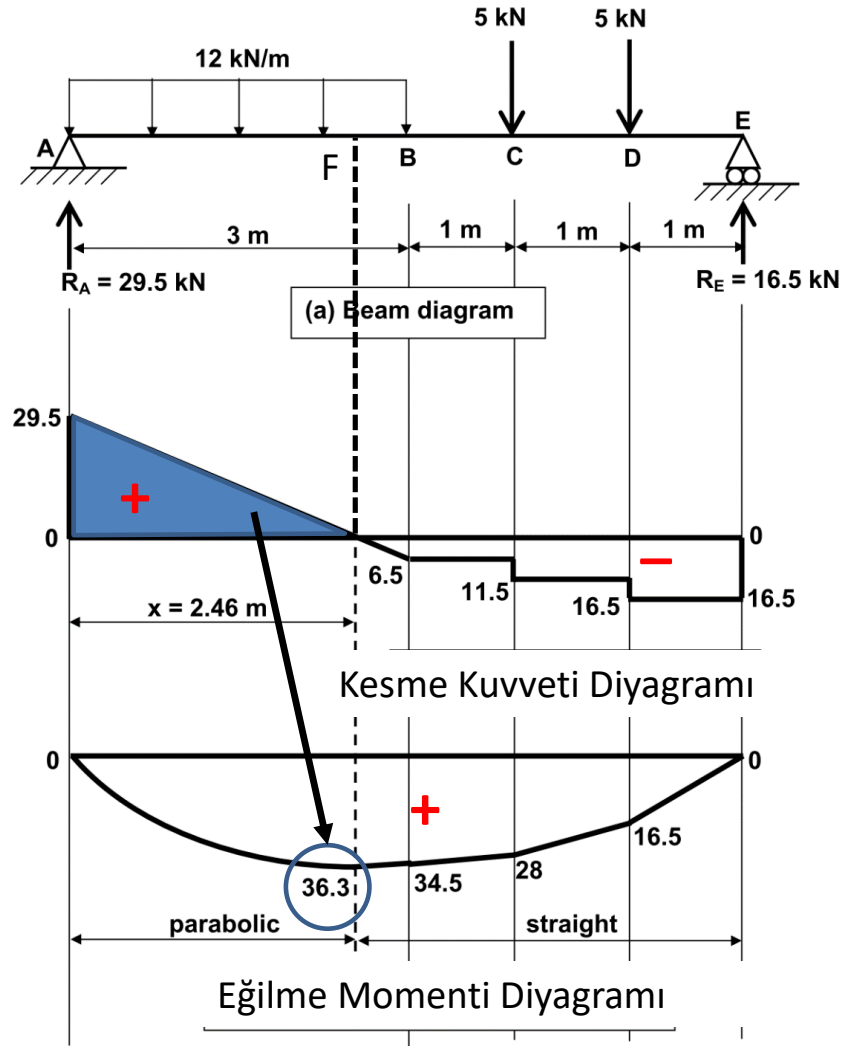

$$M_F = 29.5 \times 2.46 \times 0.5 = 36.3 \text{ kNm}$$

(T)

(M)

Mukavemet

İç Kuvvet Diyagramları

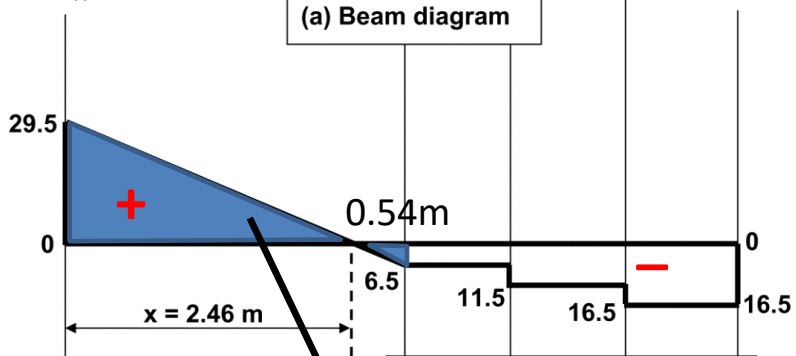
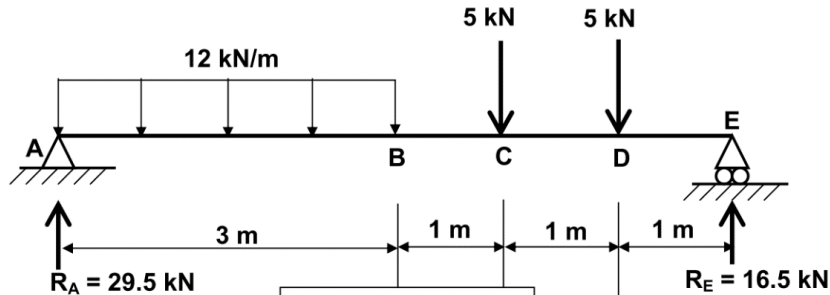

(T)

$$M_B = 36.3 - 6.5 \times 0.54 \times 0.5 = 34.5 \text{ kNm}$$

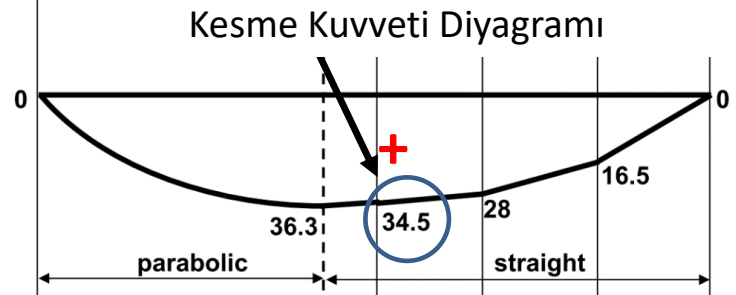

(M)

Mukavemet

İç Kuvvet Diyagramları

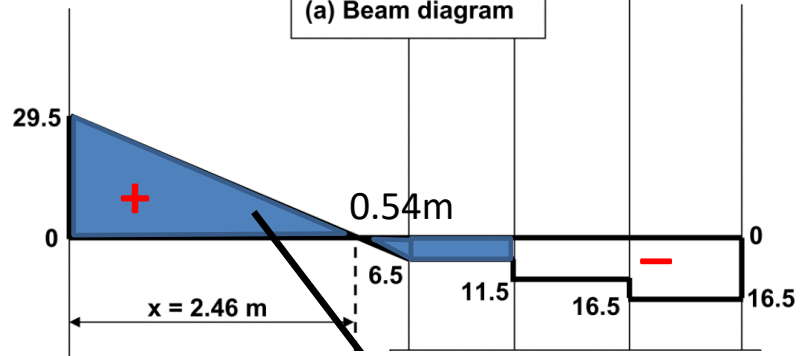
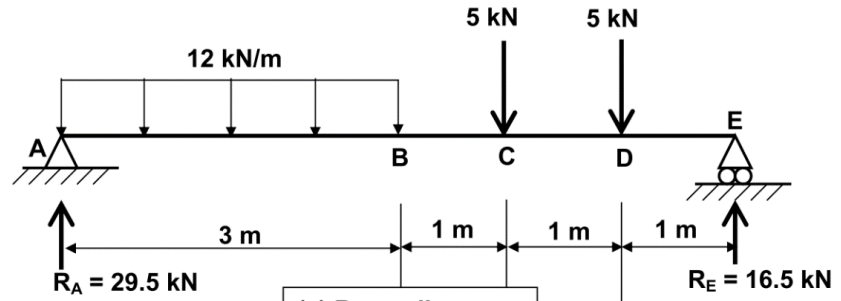

(T)

$$M_B = 34.5 - 6.5 \times 1 = 28 \text{ kNm}$$

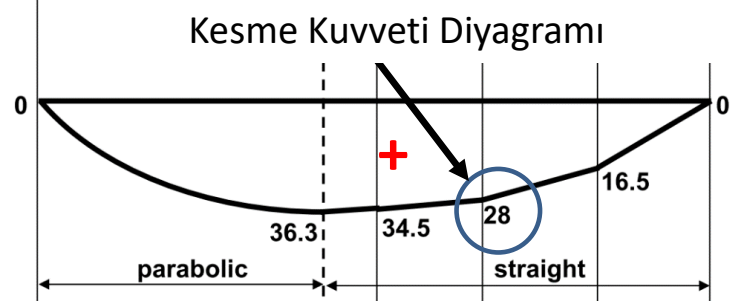

(M)

Mukavemet

İç Kuvvet Diyagramları

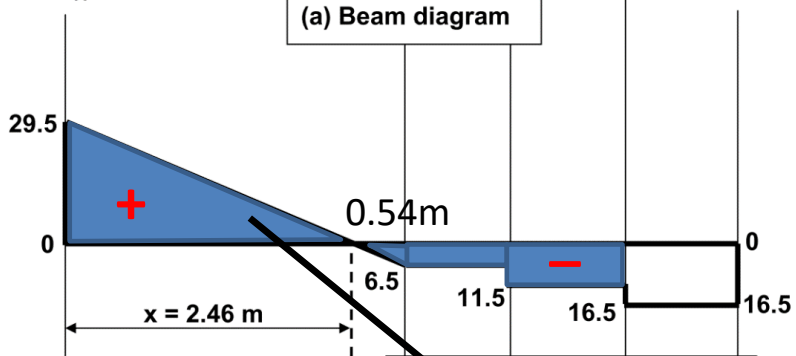
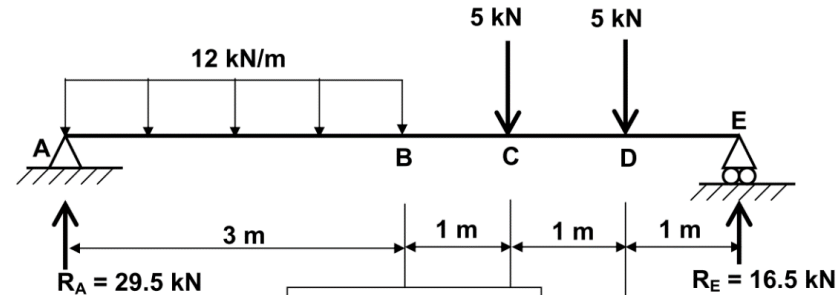

(T)

$$M_B = 28 - 11.5 \times 1 = 16.5 \text{ kNm}$$

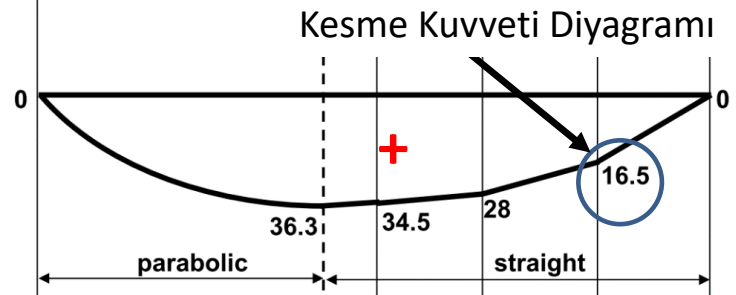

(M)

Mukavemet

İç Kuvvet Diyagramları

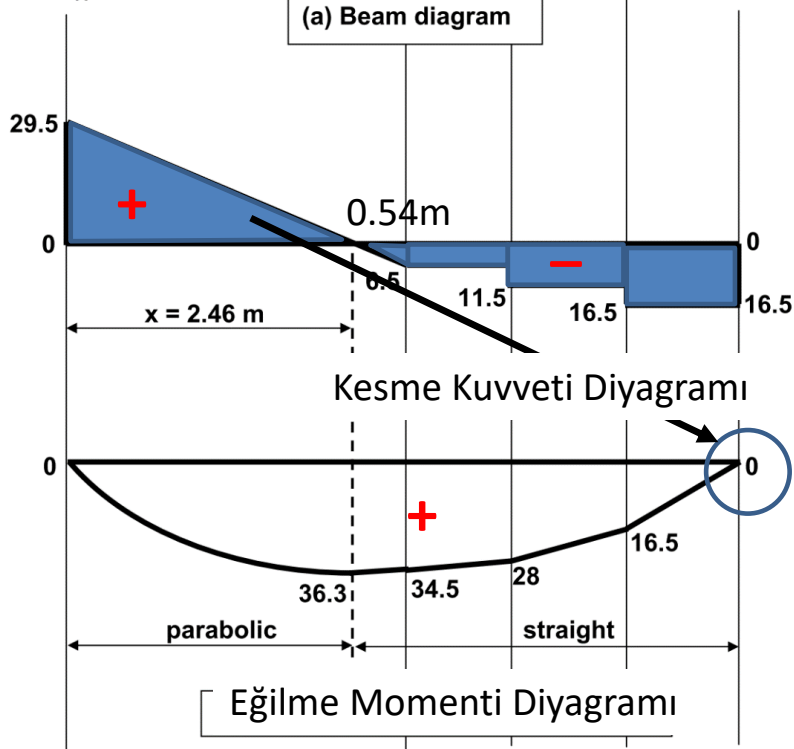
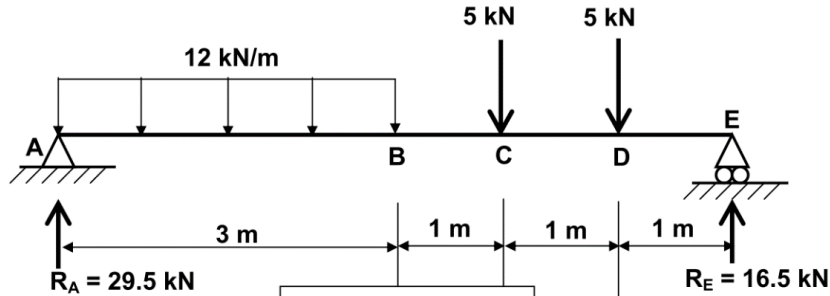

(T)

$$M_B = 16.5 - 16.5 \times 1 = 0$$

(M)

LETS REMEMBER

- The value of shear force at any point in a beam = the algebraic sum of all upward and downward forces to the left of the point.
- A beam will fail in either bending or shear. Which occurs first can only be determined by calculation.
- The bending moment is the magnitude of the bending effect at any point in a beam. The value of bending moment at any point on a beam = the sum of all bending moments to the left of the point.
- Shear force and bending moment diagrams are graphical representations of shear force and bending moment and their variation along a beam.
- The bending moment diagram is drawn either above or below the zero line, dependent on whether the beam experiences tension in the top or bottom at the point concerned (top: above the line, bottom: below the line).
- Where the shear force is zero, the bending moment is either a local maximum, a local minimum or zero. It follows from this that the position of maximum bending moment can be determined from drawing the shear force diagram first.

Moment Diyagramını Belirlemek için Pratik Bir Yöntem

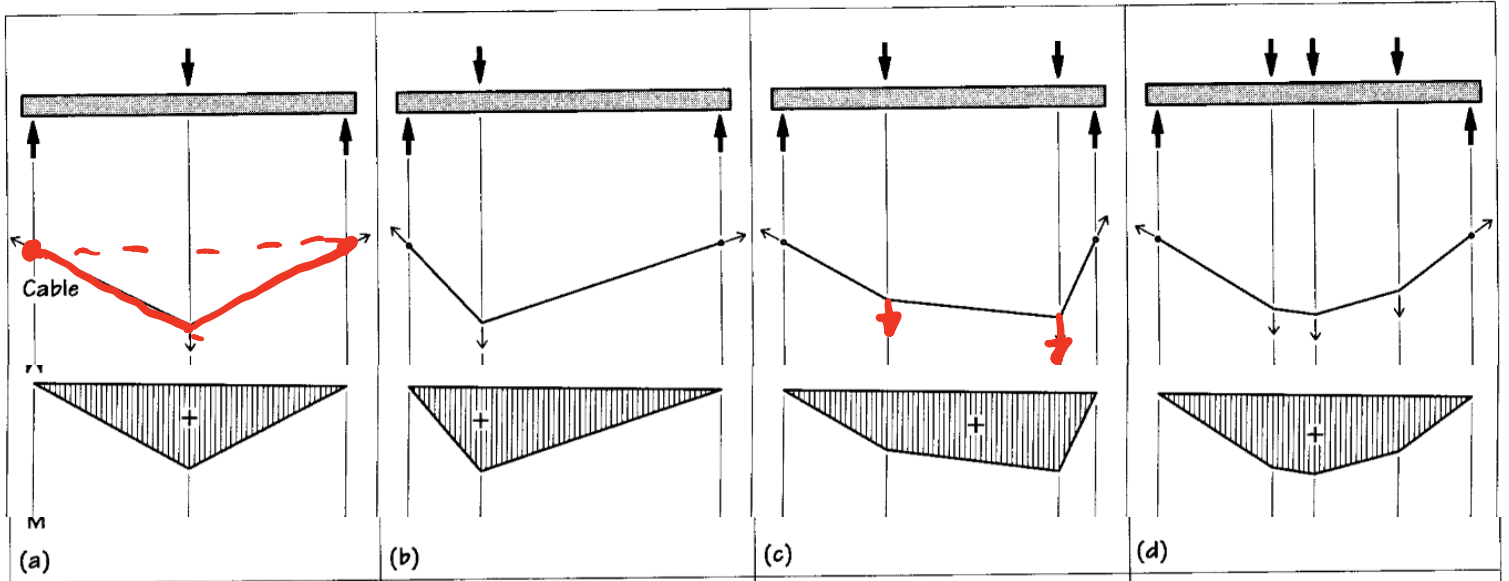

İki uçundan sabitlenmiş kabloya tekil kuvvet/kuvvetler uygulandığında kablonun aldığı form Moment diyagramı şeklini verir.

Moment Diyagramını Belirlemek için Pratik Bir Yöntem

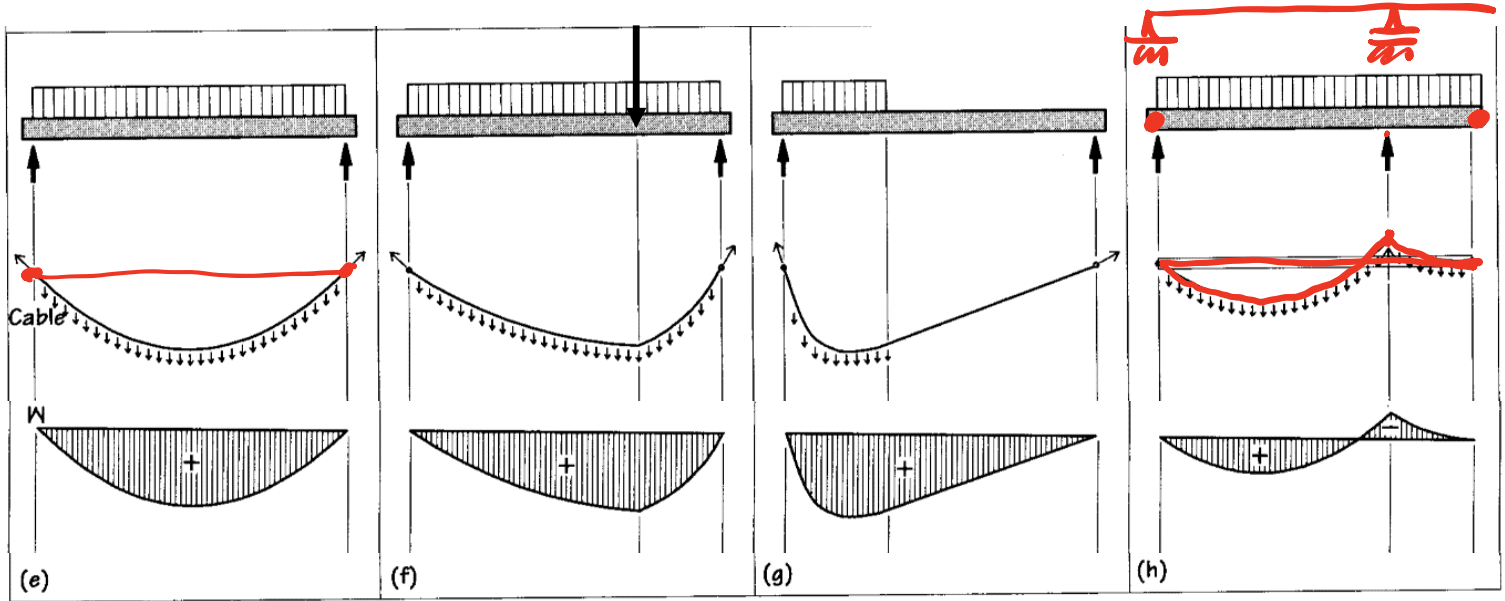

İki uçundan sabitlenmiş kabloya tekil kuvvet/kuvvetler, yayılı yük uygulandığında kablunun aldığı form Moment diyagramı şeklini verir.