

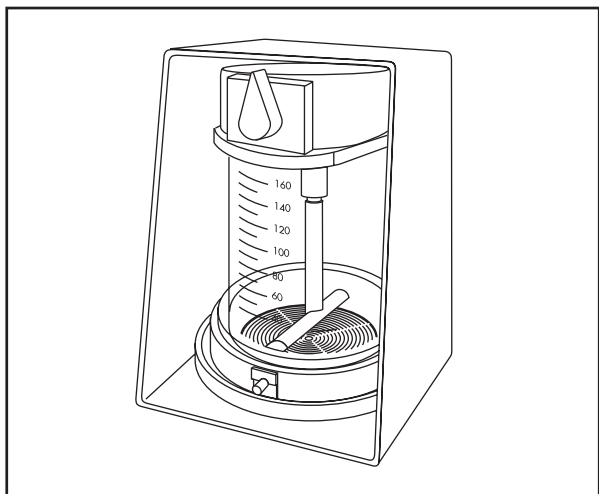

# Stirred Ultrafiltration Cells

Models 8003, 8010, 8050, 8200, 8400

## User Guide



# MILLIPORE

# Notice

The information in this document is subject to change without notice and should not be construed as a commitment by Millipore Corporation. Millipore Corporation assumes no responsibility for any errors that may appear in this document. This manual is believed to be complete and accurate at the time of publication. In no event shall Millipore Corporation be liable for incidental or consequential damages in connection with or arising from the use of this manual.

©2002 MILLIPORE CORPORATION. PRINTED IN THE UNITED STATES OF AMERICA. ALL RIGHTS RESERVED. THIS BOOK OR PARTS THEREOF MAY NOT BE REPRODUCED IN ANY FORM WITHOUT THE WRITTEN PERMISSION OF THE PUBLISHERS.

Millipore and Amicon are registered trademarks of Millipore Corporation. CelloSolve is a trademark of Union Carbide Chemicals & Plastics Technology Corporation. Tygon is a registered trademark of Norton Co.

# Contents

Introduction .....	1
Models Available .....	1
Safety Features .....	1
Model 8003 Parts List .....	2
Model 8010 Parts List .....	4
Model 8050 Parts List .....	6
Model 8200 Parts List .....	8
Model 8400 Parts List .....	10
Operating Modes .....	12
Concentration .....	12
Diafiltration .....	12
Unpacking the System .....	12
Setting Up the System .....	13
Membrane Installation .....	13
Stirrer Assembly Installation .....	14
Gas Pressure Line Installation .....	15
Operating Guidelines .....	16

---

Limitations .....	16
Pressure Limits .....	17
Temperature Limits .....	17
Chemical Resistance .....	17
Cell Operation .....	18
Shutting Down the System .....	19
Sterilization .....	20
Storage .....	20
Maintenance .....	21
Troubleshooting .....	21
Symptom: Little or No Filtrate Obtained .....	21
Symptom: Filtrate Rate Abnormally High .....	22
Symptom: Cell Leaks .....	22
Specifications .....	23
Materials of Construction .....	23
Compliance with the Pressure Equipment Directive, 97/23/EC .....	24
Accessory Equipment .....	24
CDS10 Concentration/Dialysis Selector .....	25
MF2 Push-Button Manifold .....	25
RC800 Reservoir .....	25
TA1 Tubing Adapter Kit .....	25
Technical Assistance .....	25
Standard Warranty .....	26

# Introduction

Millipore stirred ultrafiltration cells are designed for rapid concentration or purification of macromolecular solutions in volumes from 3 to 400 mL. All models are used in conjunction with a stirring table. The table is magnetically coupled to a stirring bar, which maintains fluid movement during operation, thereby reducing the negative effects of concentration polarization (i.e., the buildup of concentrated solutes on the membrane).

## Models Available

Model 8003	Catalogue number 5125
Model 8010	Catalogue number 5121
Model 8050	Catalogue number 5122
Model 8200	Catalogue number 5123
Model 8400	Catalogue number 5124

## Safety Features

- Cell has a built-in pressure-relief valve, preset to nominal 75 psi (5.3 kg/cm<sup>2</sup>). The maximum operating pressure is 60 psi (4.2 kg/cm<sup>2</sup>).
- Cell remains fixed in the retaining stand until the pressure-relief valve is opened and the cap depressed.
- Stand provides a large base for improved cell stability.

## Model 8003 Parts List

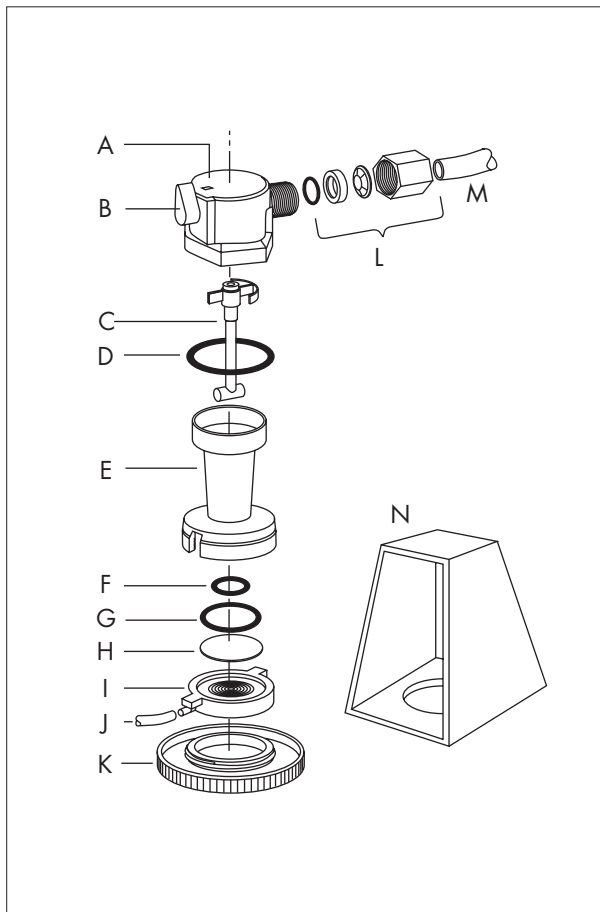

**Model 8003 Parts List**, Continued

Item No.	Description	Quantity Supplied	Replacement Catalogue Number
A	Cap Assembly	1	1524901
B	Pressure Relief Valve		—
C	Stirrer Assembly	1	1570801
D	O-Ring	2	2122S
E	Body	1	1532705
F	O-Ring	2	2015S
G	O-Ring	2	2118S
H	Membrane		—
I	Membrane Holder	1	2214801
J	Elastomeric Tubing <sup>1</sup>	4 in.	14-169-1C (Fisher Cat. No.)
K	Base	1	21000
L	Tube Fitting Assembly	2	15025AM
M	Tubing, Plastic	4 ft	XXPE00010
N	Stand Assembly	1	1570901

<sup>1</sup> You can also use Tygon® clear laboratory tubing formula R-3603, I.D. 3/32 in. (2.4 mm), O.D. 5/32 in. (4 mm).

## Model 8010 Parts List

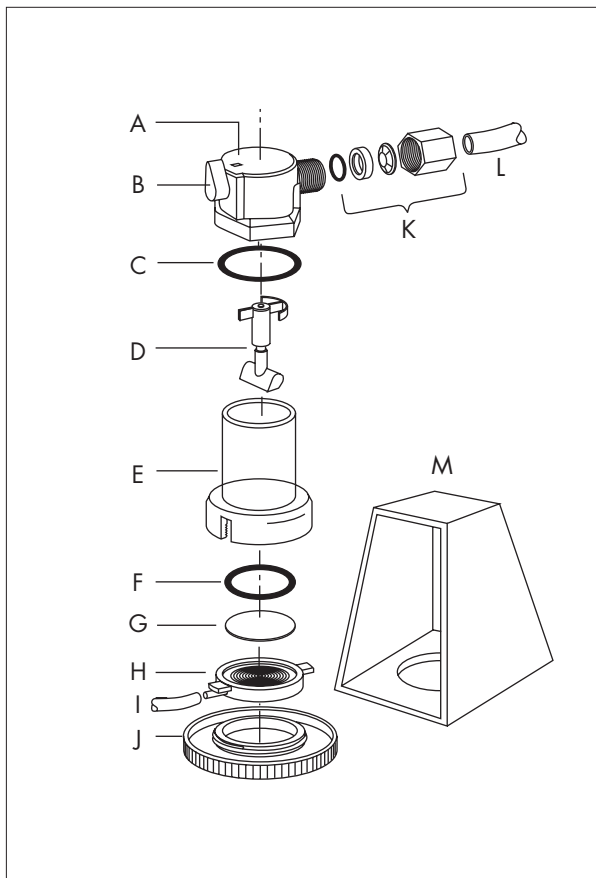



**Model 8010 Parts List**, Continued

Item No.	Description	Quantity Supplied	Replacement Catalogue Number
A	Cap Assembly	1	1524901
B	Pressure Relief Valve		—
C	O-Ring	2	2122S
D	Stirrer Assembly	1	15247
E	Body	1	1532701
F	O-Ring	2	2118S
G	Membrane		—
H	Membrane Holder	1	20998
I	Elastomeric Tubing <sup>1</sup>	4 in.	14-169-1C (Fisher Cat. No.)
J	Base	1	21000
K	Tube Fitting Assembly	2	15025AM
L	Tubing, Plastic	4 ft	XXPE00010
M	Stand Assembly	1	1532001

<sup>1</sup> You can also use Tygon® clear laboratory tubing formula R-3603, I.D. 3/32 in. (2.4 mm), O.D. 5/32 in. (4 mm).

## Model 8050 Parts List

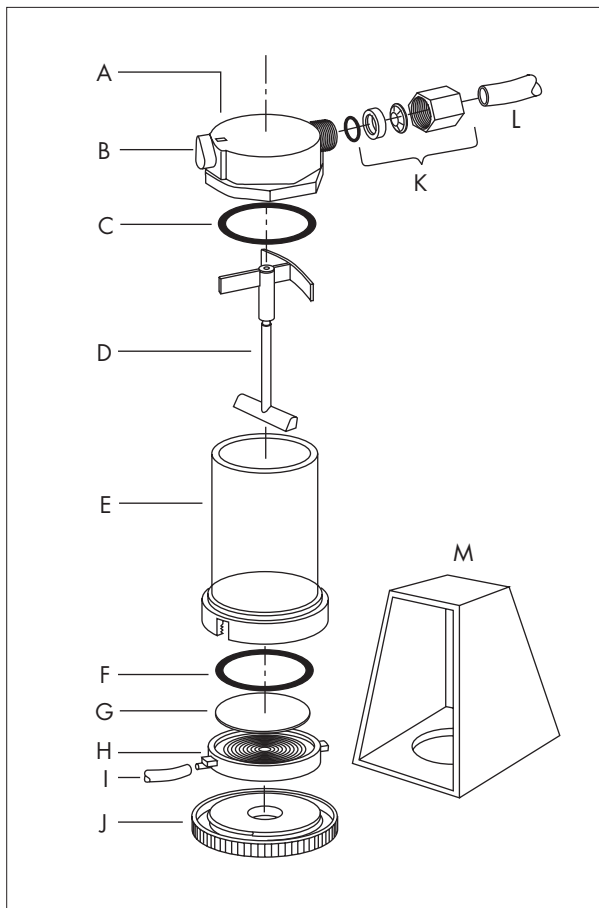

**Model 8050 Parts List**, Continued

Item No.	Description	Quantity Supplied	Replacement Catalogue Number
A	Cap Assembly	1	1524902
B	Pressure Relief Valve		—
C	O-Ring	2	2132S
D	Stirrer Assembly	1	15251
E	Body	1	1532702
F	O-Ring	2	2130S
G	Membrane		—
H	Membrane Holder	1	21117
I	Elastomeric Tubing <sup>1</sup>	4 in.	14-169-1C (Fisher Cat. No.)
J	Base	1	20987
K	Tube Fitting Assembly	2	15025AM
L	Tubing, Plastic	4 ft	XXPE00010
M	Stand Assembly	1	1532002

<sup>1</sup> You can also use Tygon® clear laboratory tubing formula R-3603, I.D. 3/32 in. (2.4 mm), O.D. 5/32 in. (4 mm).

## Model 8200 Parts List

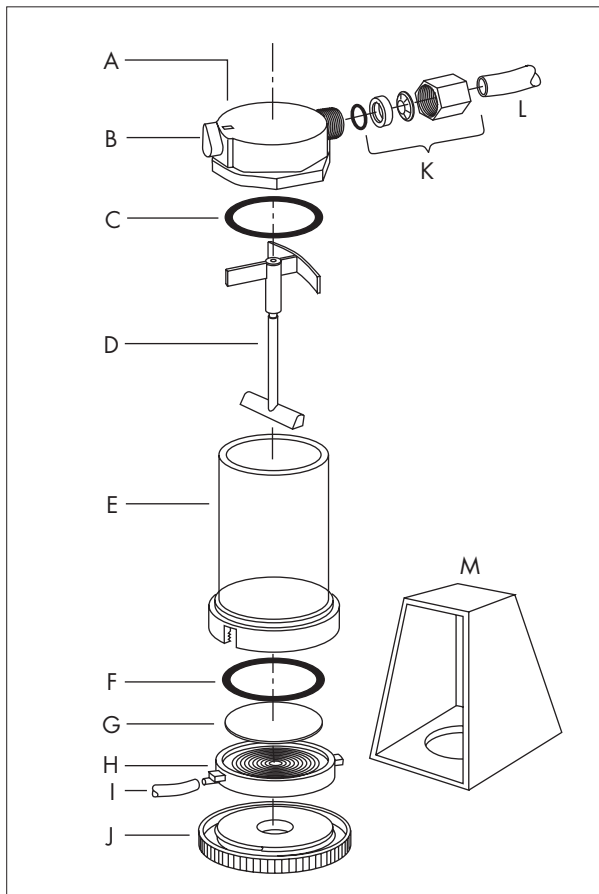

**Model 8200 Parts List**, Continued

Item No.	Description	Quantity Supplied	Replacement Catalogue Number
A	Cap Assembly	1	1524903
B	Pressure Relief Valve		—
C	O-Ring	2	2143S
D	Stirrer Assembly	1	15256
E	Body	1	1532703
F	O-Ring	2	2142S
G	Membrane		—
H	Membrane Holder	1	21005
I	Elastomeric Tubing <sup>1</sup>	4 in.	14-169-1C (Fisher Cat. No.)
J	Base	1	21011
K	Tube Fitting Assembly	2	15025AM
L	Tubing, Plastic	4 ft	XXPE00010
M	Stand Assembly	1	1532003

<sup>1</sup> You can also use Tygon® clear laboratory tubing formula R-3603, I.D. 3/32 in. (2.4 mm), O.D. 5/32 in. (4 mm).

## Model 8400 Parts List

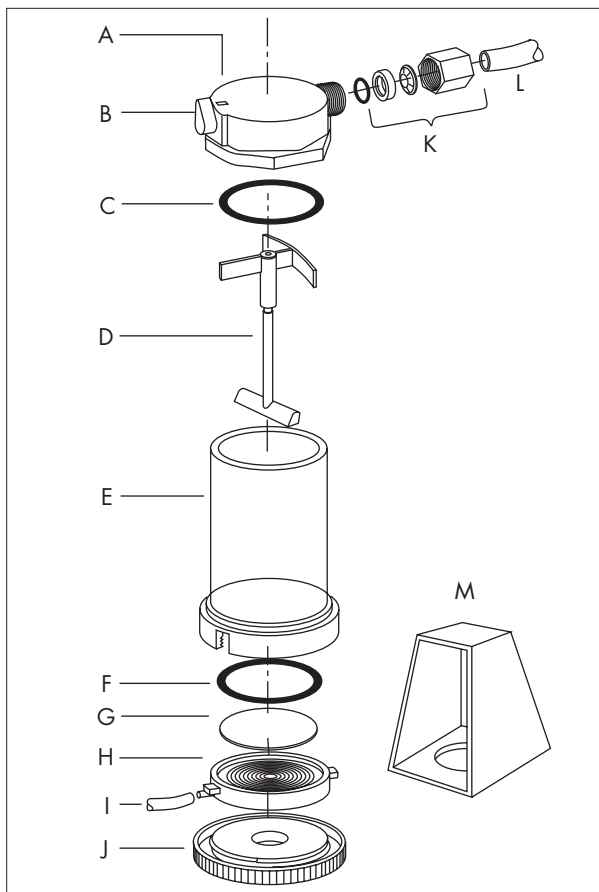

**Model 8400 Parts List**, Continued

Item No.	Description	Quantity Supplied	Replacement Catalogue Number
A	Cap Assembly	1	1524904
B	Pressure Relief Valve		—
C	O-Ring	2	2151S
D	Stirrer Assembly	1	15254AM
E	Body	1	1532704
F	O-Ring	2	2150S
G	Membrane		—
H	Membrane Holder	1	21118
I	Elastomeric Tubing <sup>1</sup>	4 in.	14-169-1C (Fisher Cat. No.)
J	Base	1	21003
K	Tube Fitting Assembly	2	15025AM
L	Tubing, Plastic	4 ft	XXPE00010
M	Stand Assembly	1	1532004

<sup>1</sup> You can also use Tygon® clear laboratory tubing formula R-3603, I.D. 3/32 in. (2.4 mm), O.D. 5/32 in. (4 mm).

## Operating Modes

Stirred ultrafiltration cells can be operated in two modes: concentration and diafiltration.

### Concentration

In this mode, apply gas pressure directly to the ultrafiltration cell. Solutes above the membrane molecular weight cut-off are retained in the cell, while water and solutes below the cut-off pass into the filtrate and out of the cell.

### Diafiltration

Here, connect the ultrafiltration cell to an auxiliary reservoir containing a diafiltrate solution with the desired microsolite concentration. Then, gas pressurize this auxiliary reservoir. Fluid volume, as well as the macrosolute concentration, remain constant as filtrate is replaced by diafiltrate solution. This technique provides a simple means for rapid microsolite exchange, and is typically used as a substitute for dialysis.

## Unpacking the System

Place cell on a level surface and remove packing inserts. Turn the pressure relief valve knob to the horizontal position. Hold the body and push the cap down. Slide the cell out of the retaining stand and remove the cap assembly with a twisting motion. Pull out the stirrer assembly and discard packing. Unscrew the base and remove the membrane holder. Remove the O-ring from the membrane holder.



## Setting Up the System

To identify the parts of the stirred cell, refer to the diagrams in the appropriate model parts list section. This section explains how to install the membrane and stirring assembly.

### Membrane Installation

**NOTE:** Handle the membrane by its edges, to avoid scratching or contaminating the surface.

1. **Model 8003 only:**

Invert the cell body and place the smaller O-ring into the recess. Gently tap to ensure that the O-ring remains when the body is upright. Place the membrane into the holder, shiny side up. Then place the larger O-ring down, so that it contacts and seats the membrane evenly in the bottom of the holder.

**All other models (8010, 8050, 8200, and 8400):**

Place the membrane into the holder, shiny side up. Place the O-ring on top of the membrane. Gently push the O-ring down, so that it contacts and seats the membrane evenly in the bottom of the holder.

2. Fit the membrane holder into the cell body, aligning the tabs on the sides of the holder with the slots in the base of the cell body.
3. Invert the cell body and membrane holder; screw the base firmly into the bottom of the cell body.
4. Push the filtrate exit tubing onto the exit spout of the membrane holder.

## Stirrer Assembly Installation

1. Place the stirrer assembly into the cell body. When properly installed, the arms of the stirrer assembly will rest on the small ridge inside the top of the cell body.
2. Pour the sample into the cell.
3. Push the cap assembly down onto the cell body, using a twisting motion and orienting the gas inlet port on the cap opposite the filtrate exit port on the holder.

**NOTE:** If the cap assembly does not slide easily, lubricate the O-ring lightly with water or petroleum jelly. Do not allow petroleum jelly to contact the membrane, to avoid clogging the membrane pores.

4. Set the pressure-relief valve knob to the horizontal (open) position.
5. Slide the cell into the retaining stand, fitting the ring on the cell base into the hole in the stand. The flattened edge on the bottom flange of the cap ensures that the cell is inserted properly and prevents rotation of the cell once inside the stand.
6. Turn the pressure-relief valve knob to the vertical (closed) position.

## Gas Pressure Line Installation

Attach the gas pressure line to the tube fitting on the cap as follows:

1. Unscrew the hexagonal nut (a) from the cap assembly and remove the O-ring (d).

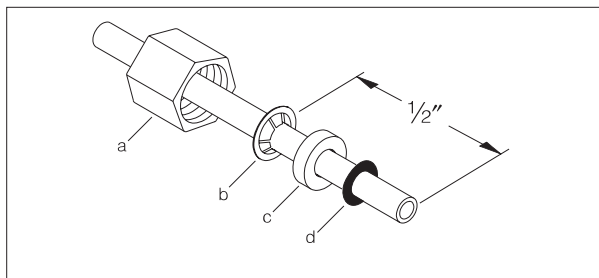

2. Slide the hex nut onto the end of gas tubing.
3. Slide the metal grab ring (b) down one half-inch onto the tubing, with the flange facing away from the hex nut.
4. Add the white spacer (c), positioning the counter-sunk surface toward the flange on the grab ring.
5. Slide the O-ring (d) onto the end of the tubing.
6. Insert the exposed tubing into the cap assembly and hand-tighten the hexagonal nut. **Do not overtighten.**

## Operating Guidelines

- See membrane instructions for cleaning and storage procedures, and for buffer and solvent compatibility.
- Highly viscous solutions filter slowly, as do solutions containing particulate matter, such as colloids. Where a viscous agent (sucrose, glycerin, etc.) is to be removed, flow can often be increased by predilution.
- Prefilter or centrifuge any solution containing particulate matter, such as cell debris or precipitates.
- During extended diafiltration, liquid level may increase slightly. To correct, concentrate briefly.
- To maximize recovery of retained substances, continue stirring for a few minutes after depressurization. This will resuspend the polarized layer at the membrane surface.

**CAUTION:** Always check that the pressure-relief valve knob is set to the horizontal (open) position, before removing the cell top. Removal of the top with the pressure-relief valve knob in the vertical (closed) position can create a partial vacuum, which can rupture the membrane.

## Limitations

This section explains the limitations of the stirred ultrafiltration cell.

## Limitations, Continued

### Pressure Limits

Do not exceed 60 psi (4.2 kg/cm<sup>2</sup>) nitrogen gas pressure.

**CAUTION:** To avoid the cap popping off and splattering its contents during pressurization, never operate the cell without its retaining stand.

### Temperature Limits

Although brief exposure to higher temperatures is possible, do not operate cell continuously above 85 °C (185 °F).

### Chemical Resistance

Do not use the stirred cell with:

Strong acids (pH < 2) or strong alkalies (pH > 10)

Ketones (including acetone)

Aromatic hydrocarbons (including toluene)

CelloSolve™

Halogenated hydrocarbons

DMF

Aliphatic esters

DMSO

Polar Aromatics

**NOTE:** The spring in the pressure-relief valve is NOT compatible with 0.1 N NaOH.

## Chemical Resistance, Continued

For other solvent compatibilities, consult a standard text or contact Millipore Technical Service. For the chemical resistance of disc membranes, see the instructions packed with the product.

## Cell Operation

1. Place the cell on the magnetic stirring table.
2. Select the cell operating mode as follows:

**For concentration:** Connect the inlet line to a regulated gas pressure source.

**NOTE:** Use nitrogen gas for pressurizing the cell. Using compressed air can cause large pH shifts, due to dissolution of carbon dioxide. With sensitive solutions, oxidation can occur also, potentially leading to other problems.

**For diafiltration:** Connect the cell to an auxiliary reservoir, using the Millipore Concentration/Dialysis Selector Switch, model CDS10 (catalogue no. 6003).

3. Hold the cell steady on the stirring table and pressurize, following the instructions in the membrane package. Do NOT exceed the cell pressure limit of 60 psi (4.2 kg/cm<sup>2</sup>). Once the system is pressurized, the cap assembly moves upward, forming a secure lock with the retaining stand.

## Cell Operation, Continued

4. To avoid membrane damage, before turning on the stirring table, make sure that the cell is pressurized.

**▲WARNING:** When operating with hazardous or especially valuable materials, pressure-check the cell thoroughly, to ensure that all components have been properly assembled, before turning on the stirring table.

5. Turn on the stirring table and adjust the stirring rate, until the vortex created is approximately one-third the depth of the liquid volume.

## Shutting Down the System

1. Turn off the stirring table and then turn off the nitrogen pressure source.

**CAUTION:** In the next step, overly rapid depressurization can cause the membrane to buckle up and rupture.

2. Slowly vent the pressure inside the cell, by turning the pressure-relief valve knob to the horizontal position. Push the cap down, and then slide the cell out from the retaining stand.
3. With a twisting motion, remove the cell cap and the magnetic stirrer assembly. Pour out the solution.

## Shutting Down the System, Continued

4. Disassemble the cell, wash all components with a mild detergent/water solution and rinse thoroughly.

**CAUTION:** Caustic cleaning solutions may damage the retaining stand.

## Sterilization

Millipore stirred ultrafiltration cells can be autoclaved at 121 °C (250 °F) for 30 minutes. They are compatible with standard sterilizing gas mixtures, 70% ethanol, isopropanol and 5% formalin. The tubing is NOT autoclavable.

**CAUTION:** To avoid pressure build-up in the body, which could result in damage, such as cracking, partially tighten the base before autoclaving.

## Storage

Disassemble the ultrafiltration cell whenever it is unlikely to be used for several weeks.



## Maintenance

- Replace O-rings at the first sign of damage or wear.
- If installation or removal of the cap assembly becomes difficult, lubricate the cap O-ring with a small amount of petroleum jelly or water.

**CAUTION:** To ensure proper filtration, do not allow petroleum jelly to come in contact with the membrane.

- Periodically inspect the transparent body for cracks and inspect the stirrer bar for washer wear or rough edges, which could damage the membrane.

**CAUTION:** If the transparent body is cracked or crazed, replace it immediately.

## Troubleshooting

### Symptom: Little or No Filtrate Obtained

- Rotate the pressure-relief valve knob to check for pressure. If the cell is not pressurized, check the nitrogen source and regulator.
- Make sure the glossy side of the disc membrane faces up.
- If the sample solution is highly viscous, due to microsolute, either dilute or diafilter to increase flow rate.
- Check the membrane holder and filtrate port for blockage.

## **Symptom: Filtrate Rate Abnormally High**

- Check the membrane for lesions, scratches and roughness.
- Make sure that the correct membrane type is being used.
- Check the stirrer assembly to ensure that the stirring bar is not contacting the membrane surface.

## **Symptom: Cell Leaks**

- Be sure that the lower O-ring rests entirely on the peripheral surface of the membrane.
- Check the O-rings for nicks or cuts.
- Make sure that the membrane support is seated properly, and that the base is screwed in firmly.
- Make sure that the O-rings have not been not squeezed out of their slots.
- Check the fittings on the gas inlet tubing for correct order and position. See the Gas Pressure Line Installation section of this user guide.

## Specifications

	8003	8010	8050	8200	8400
Cell capacity (mL)	3	10	50	200	400
Minimum process volume (mL)	0.075	1.0	2.5	5.0	10.0
Membrane diam. (mm)	25	25	44.5	63.5	76
Effective membrane area (cm <sup>2</sup> )	0.9	4.1	13.4	28.7	41.8
Hold-up volume <sup>1</sup> (mL)	0.07	0.2	0.5	1.2	1.5
Empty weight, approx. (g)	130	130	220	360	610
Retaining stand base dimensions (cm)	6 × 6	6 × 6	7 × 7	9 × 9	11 × 11
Retaining stand height (cm)	7.7	7.7	9.8	12.8	15.5

Maximum operating pressure: 60 psi (4.2 kg/cm<sup>2</sup>)

Relief valve setting: 75 psi (5.3 kg/cm<sup>2</sup>)

Maximum diafiltration operating pressure: 55 psi (3.9 kg/cm<sup>2</sup>)

<sup>1</sup> Non-recoverable volume (below membrane surface)

## Materials of Construction

Cap: nylon

Membrane holder: polysulfone

Body: polysulfone

Magnetic stirrer assembly: acetal, polysulfone

Retaining stand: nylon

O-rings: silicone rubber

Tube fitting assembly: nylon

## **Compliance with the Pressure Equipment Directive, 97/23/EC**

Millipore Corporation certifies that this product complies with the European Pressure Equipment Directive, 97/23/EC of 29 May 1997.

This product is classified under Article 3 § 3 of the Pressure Equipment Directive. It has been designed and manufactured in accordance with sound engineering practice to ensure safe use.

The product is accompanied by user instructions and bears markings to permit identification of Millipore Corporation as the manufacturer or authorized representative of this product within the European Community.

In compliance with Article 3 § 3 of the Pressure Equipment Directive, this product does not bear the CE mark.

## **Accessory Equipment**

This section lists the catalogue numbers for accessory equipment available for use with Millipore Stirred Ultrafiltration Cells. See the Technical Assistance section for information about contacting Millipore. You can also buy Millipore products on-line at [www.millipore.com/purecommerce](http://www.millipore.com/purecommerce).

## **CDS10 Concentration/Dialysis Selector**

For instant switching from concentration to rapid dialysis (diafiltration). Catalogue number 6003.

## **MF2 Push-Button Manifold**

For operation of multiple cells or reservoirs; individually valved. Catalogue number 6015.

## **RC800 Reservoir**

Provides 800 mL extra fluid volume. Can be used for rapid dialysis (diafiltration). Catalogue number 6028.

## **TA1 Tubing Adapter Kit**

Adapts plastic tubing to 1/8" or 1/4" male or female gas fittings. Catalogue number 6022.

# **Technical Assistance**

For more information, contact the Millipore office nearest you. In the U.S., call **1-800-MILLIPORE** (1-800-645-5476). Outside the U.S., see your Millipore catalogue for the phone number of the office nearest you or go to our web site at [www.millipore.com/offices](http://www.millipore.com/offices) for up-to-date worldwide contact information. You can also visit the tech service page on our web site at <http://www.millipore.com/techservice>.

## Standard Warranty

**Millipore Corporation** (“Millipore”) warrants its products will meet their applicable published specifications when used in accordance with their applicable instructions for a period of one year from shipment of the products. **MILLIPORE MAKES NO OTHER WARRANTY, EXPRESSED OR IMPLIED. THERE IS NO WARRANTY OF MERCHANTABILITY OR FITNESS FOR A PARTICULAR PURPOSE.** The warranty provided herein and the data, specifications and descriptions of Millipore products appearing in Millipore’s published catalogues and product literature may not be altered except by express written agreement signed by an officer of Millipore. Representations, oral or written, which are inconsistent with this warranty or such publications are not authorized and if given, should not be relied upon.

In the event of a breach of the foregoing warranty, Millipore’s sole obligation shall be to repair or replace, at its option, the applicable product or part thereof, provided the customer notifies Millipore promptly of any such breach. If after exercising reasonable efforts, Millipore is unable to repair or replace the product or part, then Millipore shall refund to the customer all monies paid for such applicable product or part. **MILLIPORE SHALL NOT BE LIABLE FOR CONSEQUENTIAL, INCIDENTAL, SPECIAL OR ANY OTHER INDIRECT DAMAGES RESULTING FROM ECONOMIC LOSS OR PROPERTY DAMAGE SUSTAINED BY ANY CUSTOMER FROM THE USE OF ITS PRODUCTS.**

# MILLIPORE

99228, Rev. J, 9/02