

APPENDIX A

TERMINAL REPRESENTATION OF MULTITERMINAL CIRCUIT ELEMENTS

1.1 Introduction¹

An electrical network or circuit is a collection of electrical components connected to each other at their terminals. To study the behaviour of an electrical network, therefore the characteristics of the electrical components as well as their interconnection pattern at the terminals must be known. Here our aim is to give a short discussion about the terminal representation of the electrical components.

The simplest circuit element contains two terminals and it is called a two-terminal component (2TC). If the number of terminals of an electrical component is greater than two, then it is called a multi-terminal component or, in general, if the number of its terminals is n ($n > 2$), it is named as an n -terminal circuit element (n TC). In Fig.1.1.1, a circuit containing seven two-terminal, one three-terminal, and one four-terminal component is shown. Note that the same set of circuit elements may be interconnected in a number of different ways to create other new networks, each of which exhibiting different characteristics. One of the assumptions imposed on the circuit components is that, when these components

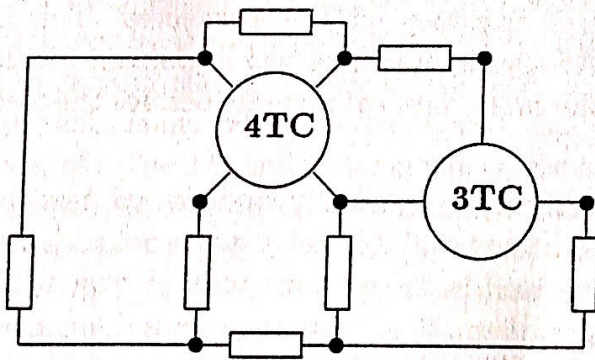

Fig.1.1.1

are interconnected in an arbitrary manner to form a network, the inherent characteristics of the components remain unaltered. Stating in a different way, in Circuit Theory each circuit

¹Summarized from the book :

Y. Tokad, *Devre Analizi Dersleri*, Çağlayan Kitapevi (third edition), İstanbul, 1996

component possesses a definite identification which is independent as to how this component is included into the network. Otherwise, i.e., if this identification is changed with the interconnection pattern of the network, either the component characterization is incomplete or it is not well-defined. Although in some theoretical studies to employ such not well-defined components is useful, they are kept outside the present discussion. However, in order to illustrate that such components indeed may appear, consider a two-terminal inductor which is going to be included in a network in which let there be other inductors besides some different electrical components. After connecting the two-terminal inductor into the network at its terminals, if this inductor influences the other inductors in the network not only at the electrically connected terminals but also through the magnetic couplings or became influenced by these inductors magnetically, we conclude that the well defined characteristics of this two-terminal inductor which was valid in an absolute isolation now is altered during its inclusion into the network. Therefore it will not be true to treat each one of these inductors as a single inductor. In such situations the best thing that one can do is to consider totality of these inductors as a single multi-terminal component.

In a given circuit, the terminals at which the electrical components are interconnected to each other form the nodes of the circuit. As an example, in the circuit in Fig. 1.1.1, the number of nodes is eight.

We can conclude from the above short discussion that, there are two basic pieces of information in the formation of an electrical network : The first of these is about the two-terminal or multi-terminal components that constitute the building blocks of the circuit; the second is about the interconnection pattern of these components at their terminals. For this reason, before starting to analyze a given electrical network, one should know what are the building blocks that form the network and which way they are interconnected. This information constitutes the first step of the **Circuit Analysis** and these two important pieces of information are also necessary for the analysis of the other physical systems besides the electrical networks.

When we talk about the circuit analysis, it is usually understood the operation through which all the unknown voltage and current variables of a given network be calculated. For this reason, the properties of each component in the network and the interconnection pattern of these components are converted into a mathematical language. Once the mathematical descriptions of the properties for the components and their interconnection information are obtained, then the analysis problem is reduced to that of mathematics and from this point on the well known mathematical techniques can be used for its solution. The whole process of converting the physical informations (component properties and the interconnection pattern) into two different mathematical form is called as **mathematical modelling**. A mathematical model for each component and the mathematical model for the interconnection pattern of components together constitute the basis of the discipline of circuit analysis. These two mathematical

models are discussed in the following sections separately.

1.2 Circuit Elements and Their Mathematical Model

Circuit elements or components are the building blocks of a network. As explained above, their properties can be put into a mathematical representation by making a number of observations (electrical measurement) at the terminals of the components. Therefore, when an electrical network is given, we must first identify the components included in this network. The identification of each component may not be easy by a simple inspection of the network. Indeed, as can be seen from the example given in the previous section, in the network if one element is coupled electrically and magnetically to some other elements, the totality of these elements must be considered as a single multi-terminal component². After distinguishing the components in the given network, each component can be isolated by disconnecting it from the given network and its properties can be studied in this absolute isolation state. We assume that the properties of a component can be discovered by making some measurement at its terminals. The quantities to be measured at the terminals during this operation are the voltages and currents.

Since the simplest electrical component possesses only two terminals, we shall consider first a two-terminal component represented by a thick rectangle as in Fig. 1.2.1. The measurement that can be done at the terminals A_1 and A_2 of this component are only the voltage between these terminals and the current flowing through the component. In order to measure these quantities, they must be present at the terminals of the component. To make this possible, terminals A_1 and A_2 of the component can be connected to a source (S) or between any two nodes of a network (an excitation circuit) containing sources in it³. The voltage and the current can now be measured by the help of a voltmeter and an ammeter which are connected at the terminals of the components as shown in Fig.1.2.1 (a). We assume here that both the meters measure the instantaneous values of the voltage and current variables. In general, terminals (two in numbers) of either the voltmeter or the ammeter must be distinguished from each other. Indeed, if the terminals of a meter are shifted, it will indicate the same number however with opposite sign. For this reason, once for all, one of the terminals of a meter must be marked, e.g., by a sign (+) or by a red color. This operation may be called **orientation** of the meter.

²The method of **Tearing and Reconstruction** (Diakoptics) will be introduced in a future chapter requires the division of a given network into several parts (subnetworks) each of which can be analysed easily. Each of these subnetworks can be considered as a multi-terminal network. Here it is assumed that the division is performed in such a way that these multi-terminal subnetworks can only act on each other electrically through their interconnected terminals.

³If the two-terminal component contains sources in it, its excitation at the terminals becomes unnecessary since the quantities to be measured at the terminals already exist.

To make voltage and current measurement, both the voltmeter and the ammeter in Fig. 1.2.1(a) each may be connected to the terminals of the component in two different ways. Hence we can obtain four different (voltage, current) pairs. If the instantaneous values of the measured quantities are indicated by $v(t)$ and $i(t)$, one of the measured pair can be written as $(v(t), i(t))$. By a simple mathematical operations other three pairs can therefore be obtained from this pair as in the forms $(v(t), -i(t))$, $(-v(t), i(t))$ and $(-v(t), -i(t))$. This suggests that if we are agree to use only one of these pairs, other possible three measured pairs are automatically known, hence they can be omitted from further consideration. Let the oriented meters be connected to the terminals A_1 and A_2 of the two-terminal component as shown in Fig.1.2.1 (b). To indicate this type of connections of the meters we may use an oriented line segment with its two end points a_1 and a_2 corresponding to the terminals A_1 and A_2 of the component. Orientation on this line segment is in a one-to-one correspondance with the meter orientation. If the orientation of the line segment is changed, its direction now becomes from a_2 to a_1 , then the orientations of both meters must be changed simultaneously.

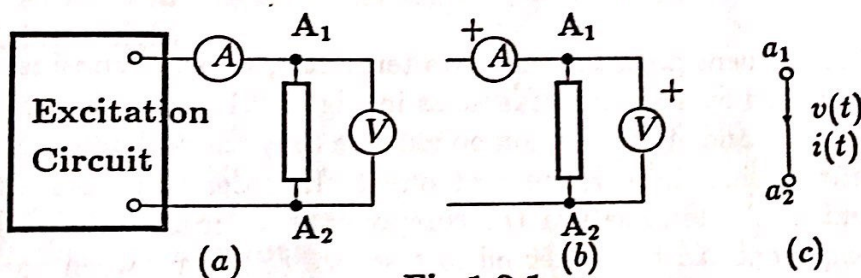

Fig.1.2.1

From the above discussion now it is clear that the oriented line segment in Fig. 1.2.1(c) describes completely the orientation of the meters when both a voltage and a current measurement are made at the terminals of a two-terminal component. For this reason this oriented line segment is called the terminal graph of the two-terminal component possessing the terminals A_1, A_2 . The functions indicated by $v(t)$ and $i(t)$ which appear on the terminal graph represent the instantaneous values of the quantities measured at the terminals of the two-terminal component. The quantities $v(t)$ and $i(t)$ measured at the terminals of the two-terminal component are called the terminal variables.

Consider now the inherent property of the two-terminal component. This property is actually related to the physical phenomenon that actually occur inside the component which can be observed at the terminals of the component as a relationship between the terminal variables $v(t)$ and $i(t)$. This relation is independent of the time variations of the terminal variables and it sometimes is in the form of an algebraic equation or in the form of an differential

equation. It is called the terminal equation of the two-terminal component. Hence the terminal equation of a two-terminal component, for instance may have either of the forms $f(v, i) = 0$, $f(v, i dv/dt, di/dt) = 0$ or may have a form in which the terminal variables and their higher order derivatives and also the time variable separately may appear.

It is expected that the establishment of the terminal equations of a two-terminal component requires a series of measurement which must be made at the terminals of the component. However the success of this approach depends on the internal complexity of the component since it will appear as a terminal equation in the form of a complicated expression. For this reason, in network theory it is best to consider those two-terminal basic components possessing the simplest terminal equations. More complicated two-terminal components then may be thought as they are made by the combination of these basic components. Therefore at the beginning, we conveniently restrict our discussion to the consideration of only those circuits containing the basic type of two-terminal components.

The above discussion indicates clearly that a selected terminal graph and the terminal equation associated with it together describe mathematically complete properties of the two-terminal component. For this reason the pair {terminal graph; terminal equation} constitute the mathematical model of that component.

Example - 1.2.1 In Fig.1.2.2 the mathematical model of a semi-conductor diode is given. Since the terminal graph can be taken in two different ways, mathematical models corresponding to these cases are indicated separately in Fig. 1.2.2(b) and (c). However, instead of given the terminal equation of the diode in terms of a nonlinear such expression like $f(v(t), i(t)) = 0$, here this relation given graphically. This model being the static characteristics of the diode, will be valid only for slowly changing terminal variables. When the terminal variables changes rapidly with time then the terminal equation of the diode becomes complicated perhaps containing the derivatives of the terminal variables.

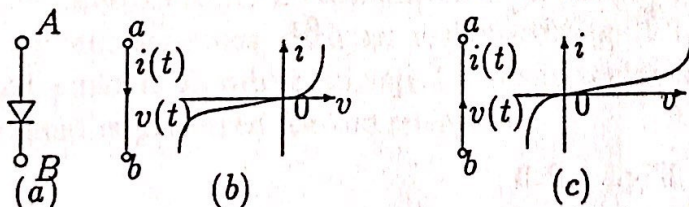

Fig. 1.2.2

(a) Symbol of semiconductor diode.
(b) and (c) Mathematical models.

The concept of mathematical model described in the foregoing discussion for two-terminal components can be extended easily to the multi-terminal components. In this case, however,