

DEPREME DAYANIKLI YAPI TASARIMI

Zekai Celep
İnşaat Fakültesi
İstanbul Teknik Üniversitesi

DEPREME DAYANIKLI YAPI TASARIMI

- Deprem hareketi
- Yapıların yer hareketi etkisindeki titreşimi
- Deprem etkisindeki betonarme yapı elemanlarının davranışı
- Depreme dayanıklı yapı tasarımı
- Yurdumuzdaki önemli depremler
- Yapılarda deprem sonrası hasar belirlenmesi, onarım ve güçlendirme yöntemleri
- Mevcut binaların deprem etkisindeki davranışının değerlendirilmesi

Deprem etkisindeki betonarme yapı elemanlarının davranışı

Beton

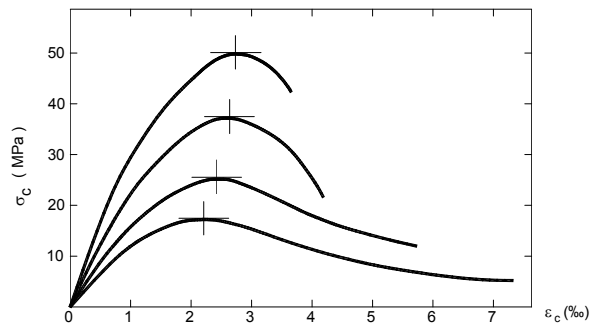

Beton

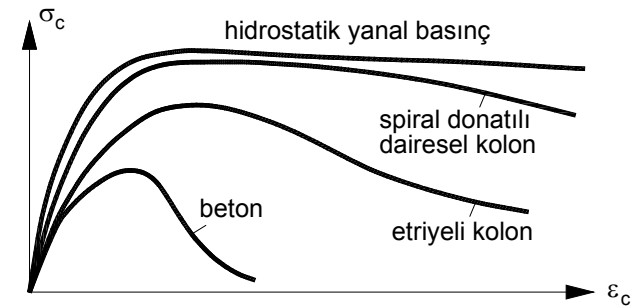

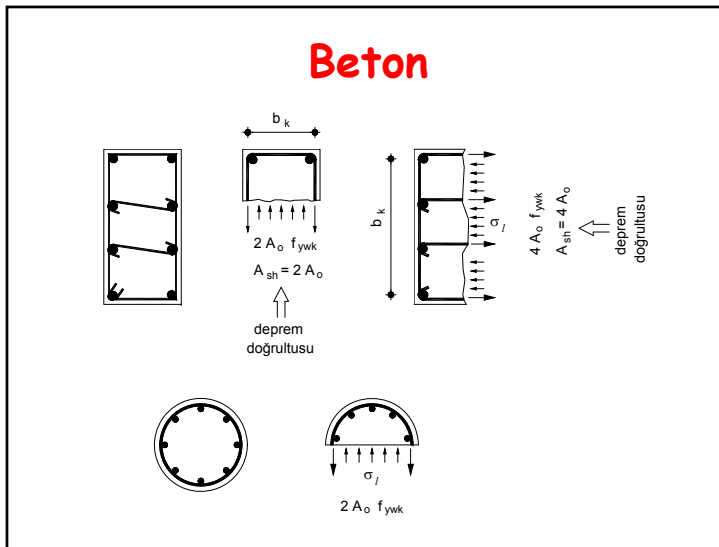
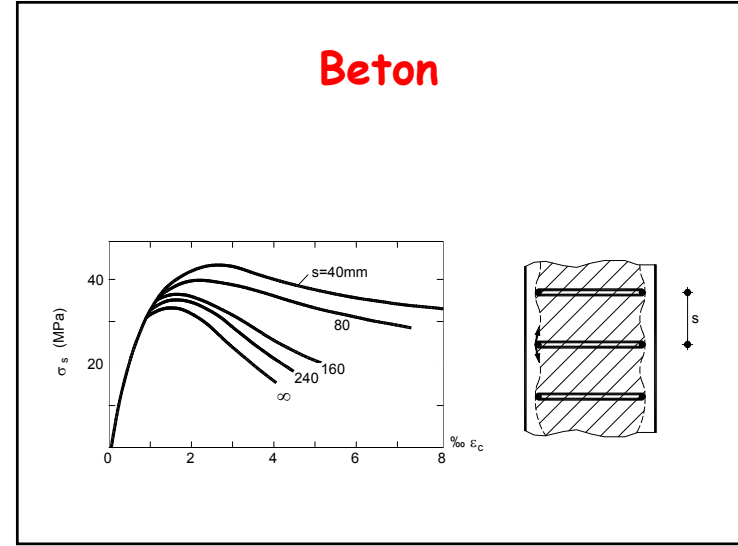
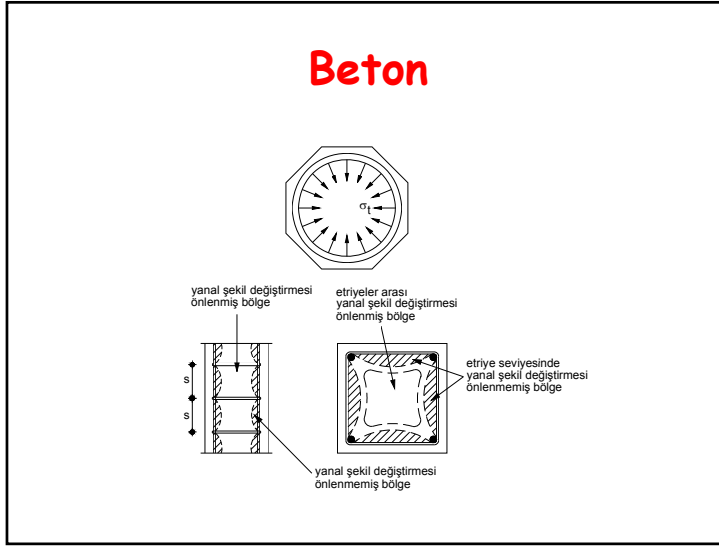

Beton

$$0.85 f_{ck} (A_c - A_{ck}) \leq 4.1 \sigma_l A_{ck} \quad \sigma_l = \frac{A_{sh} f_{ywk}}{s b_k}$$

$$A_{sh} \geq A_{sh \min} = 0.207 \frac{f_{ck}}{f_{ywk}} \left(\frac{A_c}{A_{ck}} - 1 \right) s b_k$$

$$\rho_s = \frac{\pi D A_o}{s \pi D^2 / 4} = \frac{4 A_o}{s D} \geq \rho_{s \min} = 0.415 \frac{f_{ck}}{f_{ywk}} \left(\frac{A_c}{A_{ck}} - 1 \right)$$

Beton

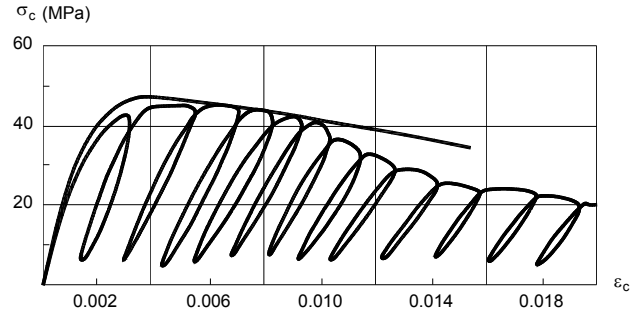

Çelik

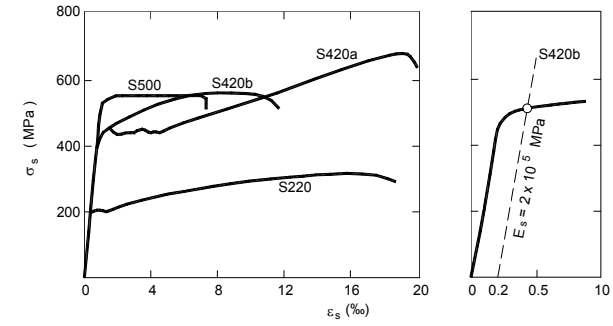

Çelik

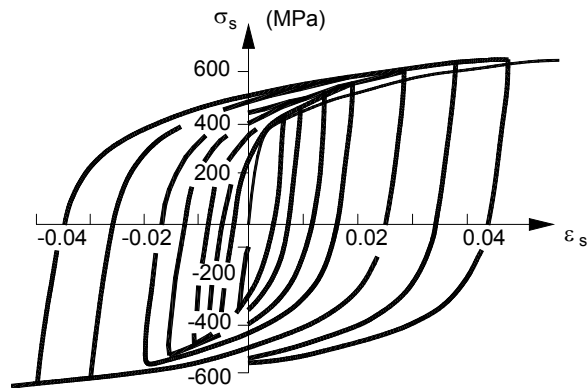

Döşemeler

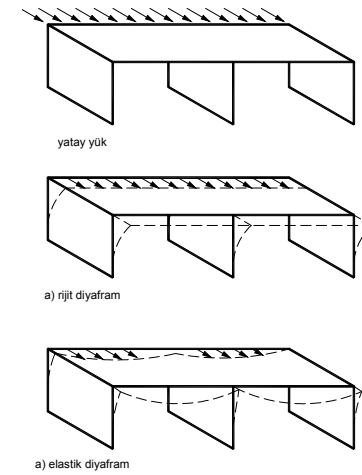

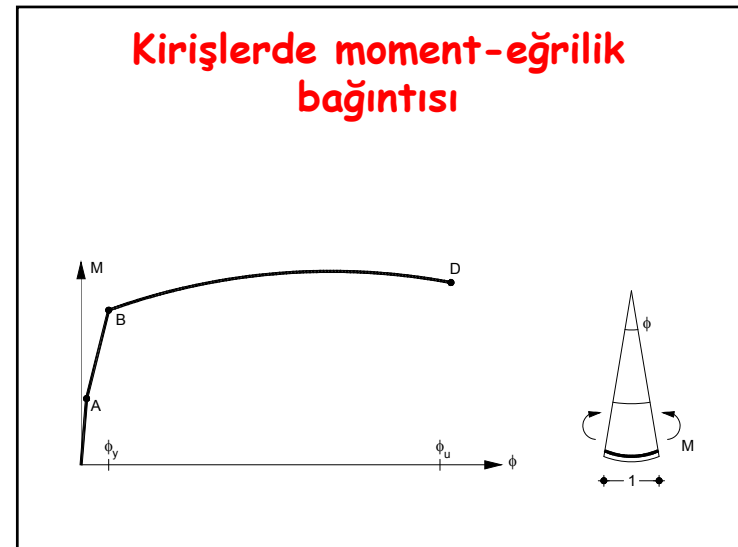
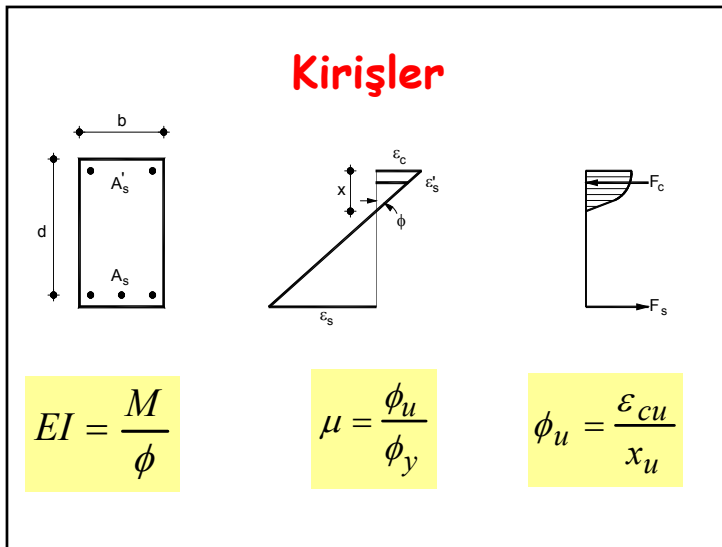
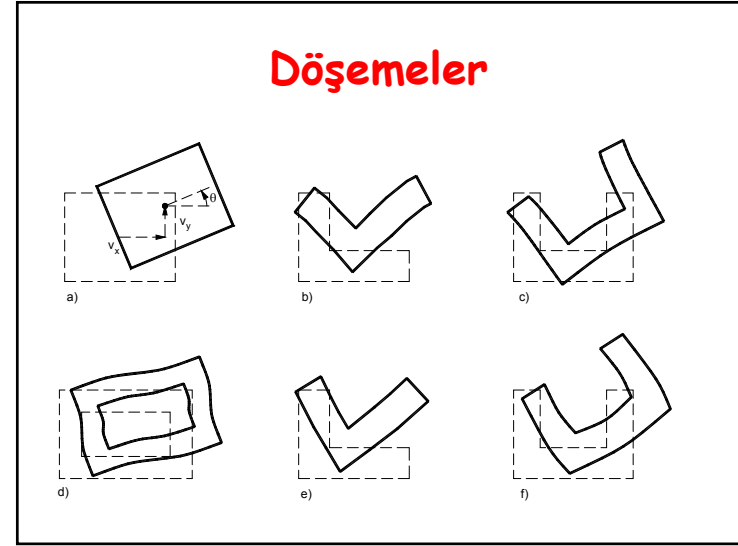
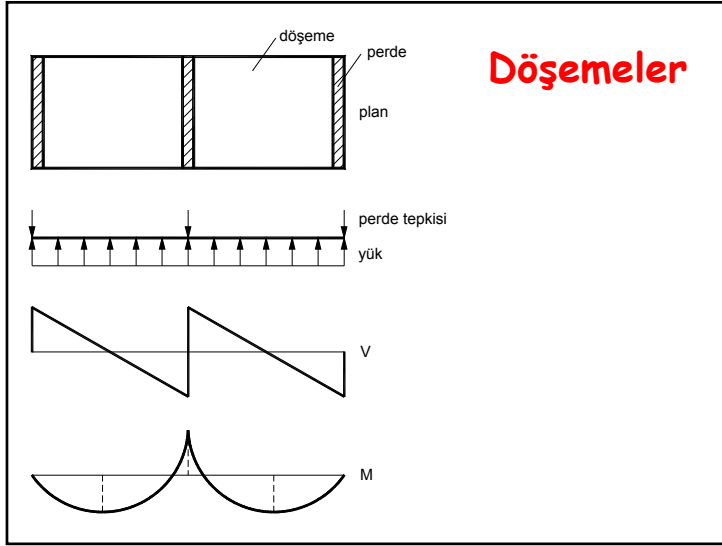

Kirişlerde moment-eğrilik bağıntısı

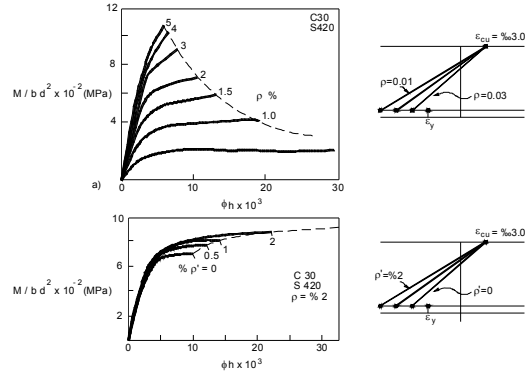

Kirişlerde moment-eğrilik bağıntısı

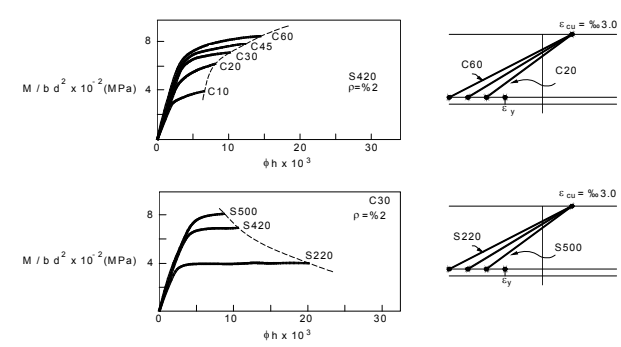

Moment-eğrilik bağıntısı

$$0.85 f_c b a = A_s f_y$$

$$M_u = 0.85 f_c b a (d - 0.5 a)$$

$$M_u = A_s f_y (d - 0.5 a) \quad a = k_1 x$$

Kirişler

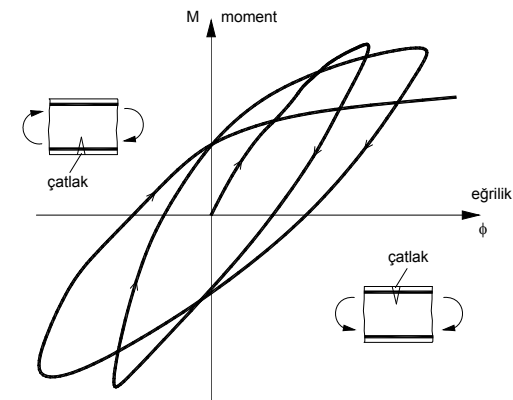

Kolonlar

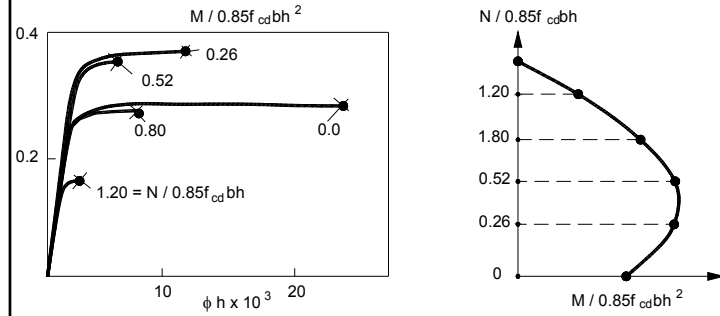

Kolonlar

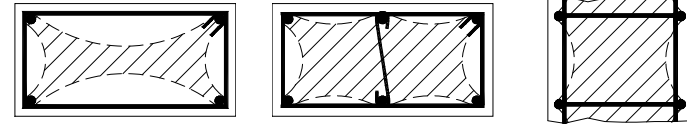

yanal şekil değişirmesi önlenmiş beton bölgesi

Kolonlar

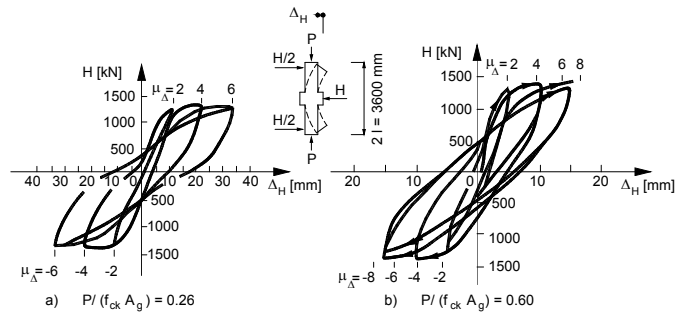

a) $P / (f_{ck} A_g) = 0.26$

b) $P / (f_{ck} A_g) = 0.60$

Perdeler

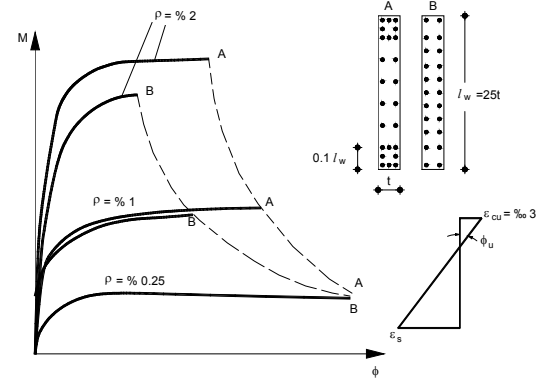

Perdeler

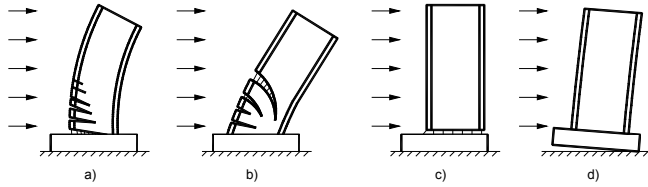

Perdeler

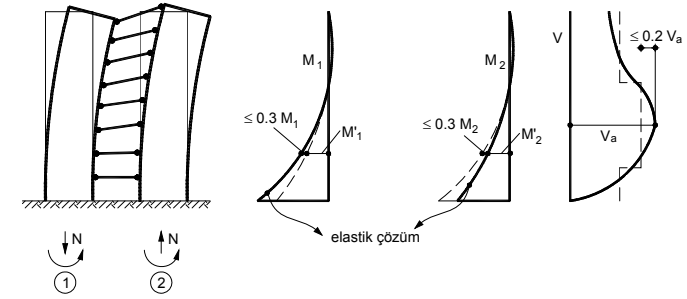

Perdeler

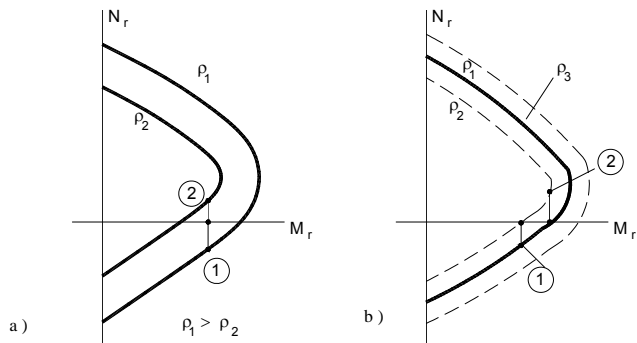

Perdeler

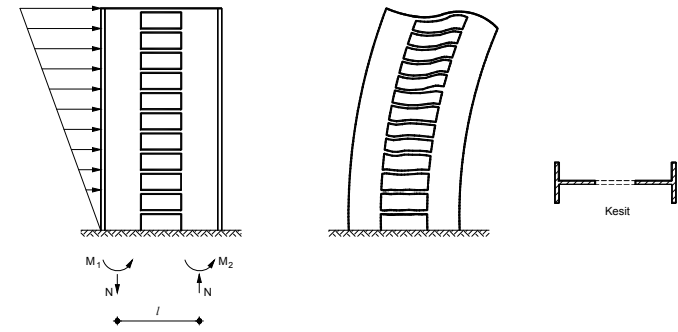

Perdeler

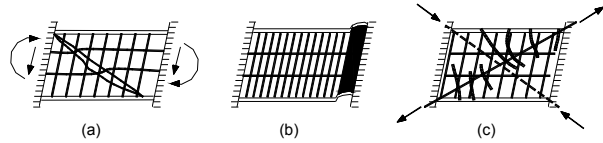

Perdeler

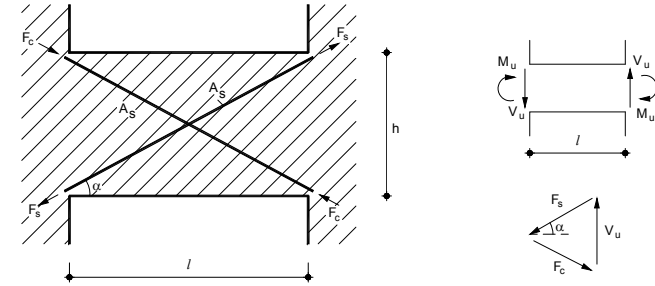

Perdeler

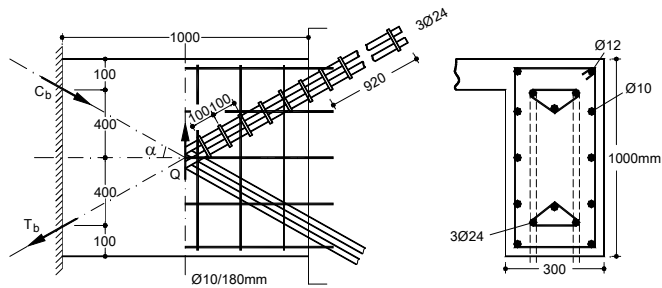

Perdeler

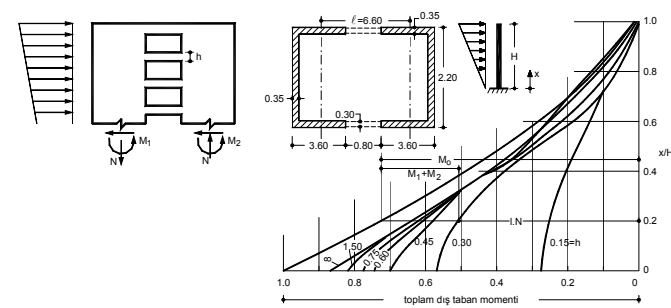

Perdeler

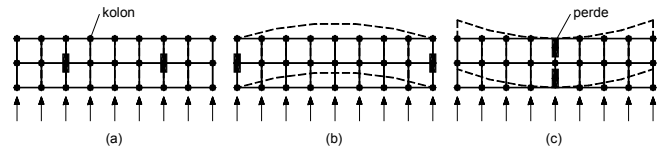

Perdeler

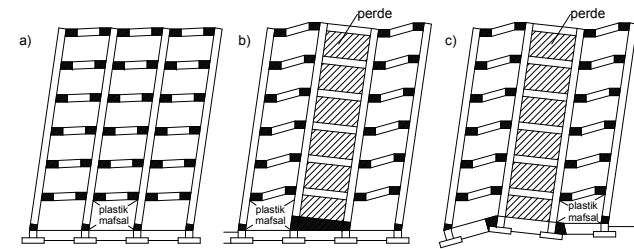

Birleşim bölgeleri Kolon ile döşeme

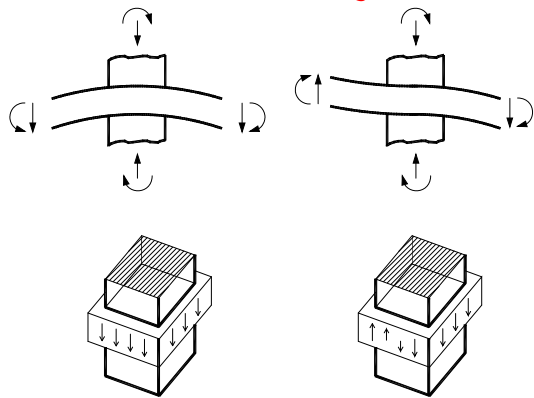

Birleşim bölgeleri Kolon/perde ile döşeme

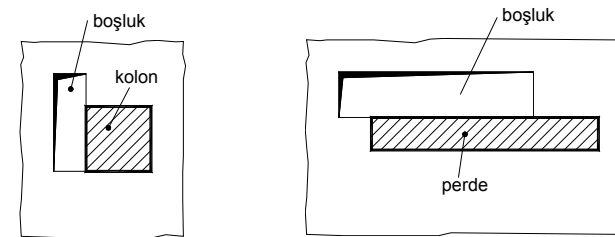

**Birleşim bölgeleri
Kolon ile kiriş**

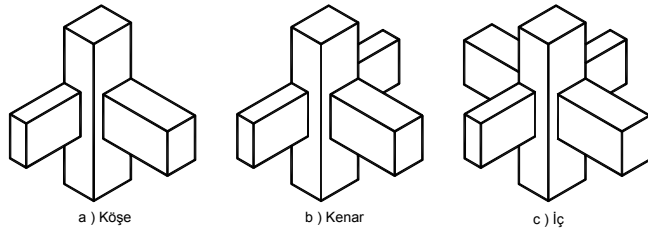

**Birleşim bölgeleri
Kolon ile kiriş**

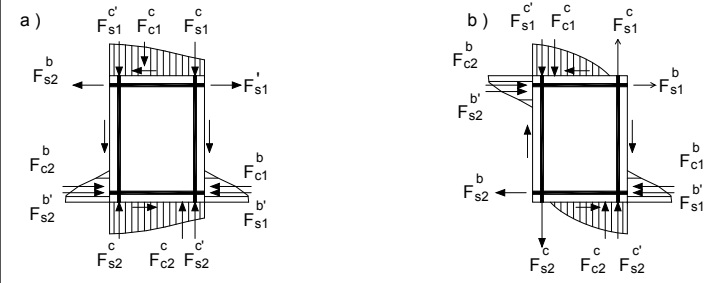

**Birleşim bölgeleri
Kolon ile kiriş**

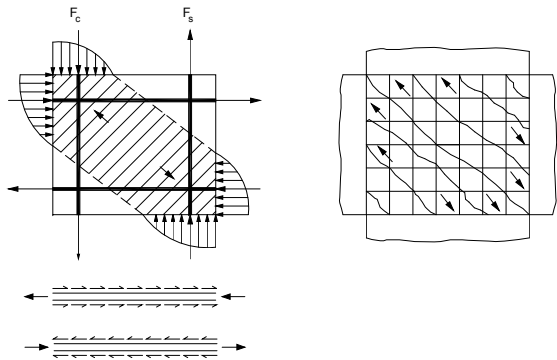

**Birleşim bölgeleri
Kolon ile döşeme**

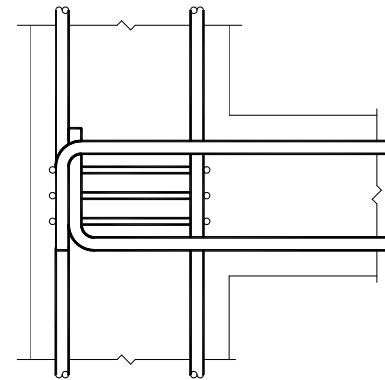

**Birleşim bölgeleri
Kolon ile kiriş**

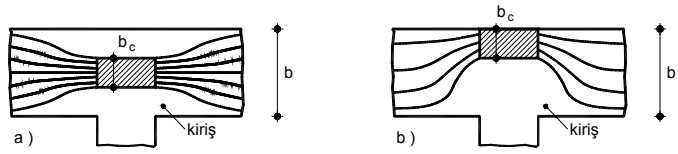

**Birleşim bölgeleri
Kolon ile kiriş**

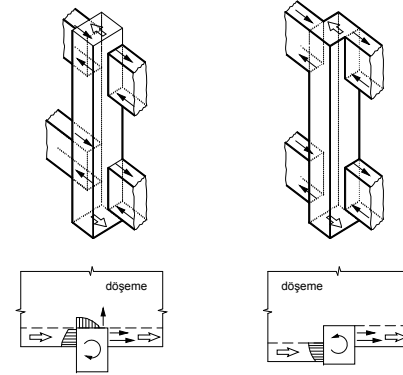

**Birleşim bölgeleri
Kolon ile kiriş**

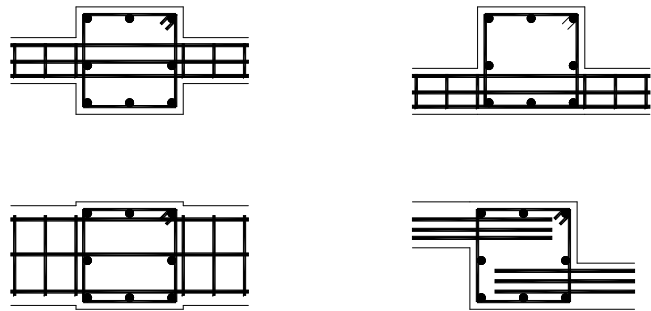

**Birleşim bölgeleri
Kolon ile kiriş**



Plastik mafsal ve sünelik

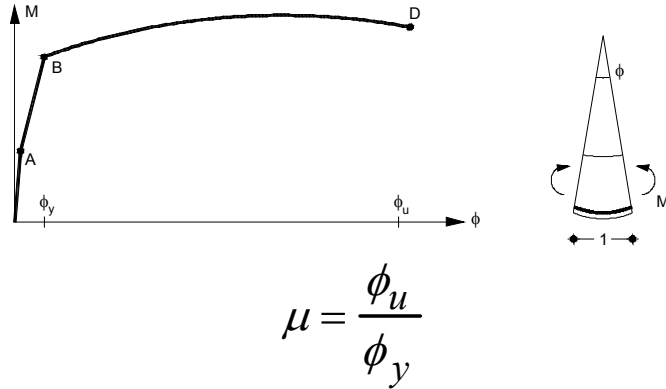

Konsol kirişte moment-eğrilik değişimi

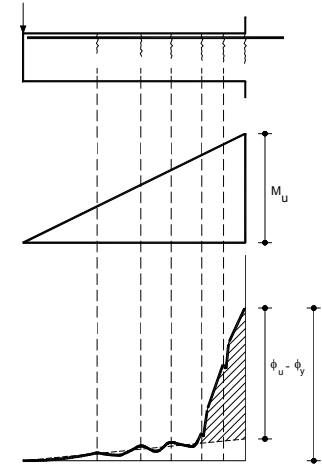

Plastik mafsal

$$\theta_{AB} = \int_A^B \phi \, dx = \int_A^B \frac{M}{EI_e} \, dx \quad \Delta_{AB} = \int_A^B x \frac{M}{EI_e} \, dx$$

$$I_e = \left(\frac{M_{cr}}{M} \right)^3 I_g + \left[1 - \left(\frac{M_{cr}}{M} \right)^3 \right] I_{cr}$$

$$\theta_p = (\phi_u - \phi_y) \ell_p$$

Plastik mafsal

$$\theta_{AB} = \theta_e + \theta_p = 0.5 \ell \phi_y + (\phi_u - \phi_y) \ell_p$$

$$\Delta_{AB} = \phi_y \frac{\ell}{2} \times \frac{2\ell}{3} + (\phi_u - \phi_y) \ell_p \left(\ell - \frac{\ell_p}{2} \right)$$

$$\ell_p = 0.25 d + 0.075 z$$

$$\theta_p = \left(\frac{\varepsilon_{cu}}{x_u} - \frac{\varepsilon_{ce}}{x_e} \right) \ell_p$$

$$\ell_p = 0.50 d + 0.050 z$$

Kat kiriş ve kolonlarında plastik mafsal

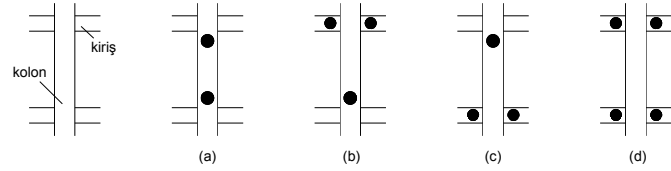

Çerçeve plastik mafsal

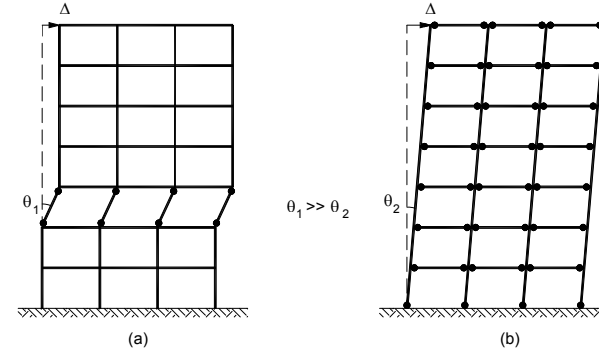

Boyutlamada kapasite ilkesi

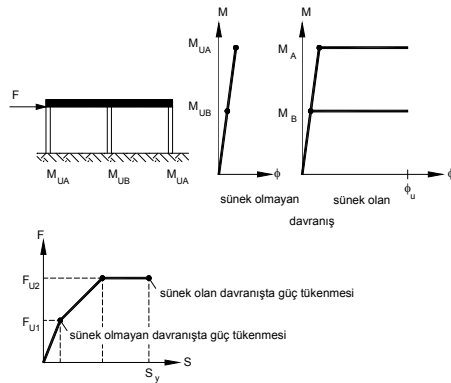

Boyutlamada kapasite ilkesi

$$F_{U1} = \frac{M_{UA}}{h/2} + \frac{M_{UB}}{h/2} + \frac{M_{UA}}{h/2} = \frac{6M_{UB}}{h}$$

$$F_{U2} = \frac{M_{UA}}{h/2} + \frac{M_{UB}}{h/2} + \frac{M_{UA}}{h/2} = \frac{2}{h} (2M_{UA} + M_{UB})$$

$$M_{UA} = 2 M_{UB}$$

$$F_{U2} = \frac{10M_{UB}}{h}$$